

Specifications

Telescopic Boom Truck Crane

HTC-8650

50-ton (45.36 metric tons)

Series II

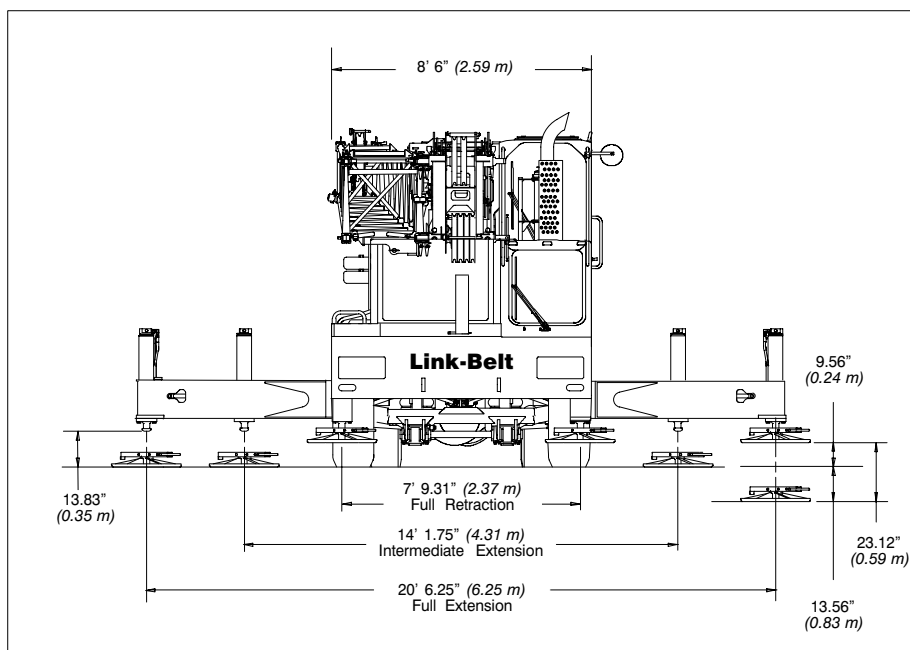
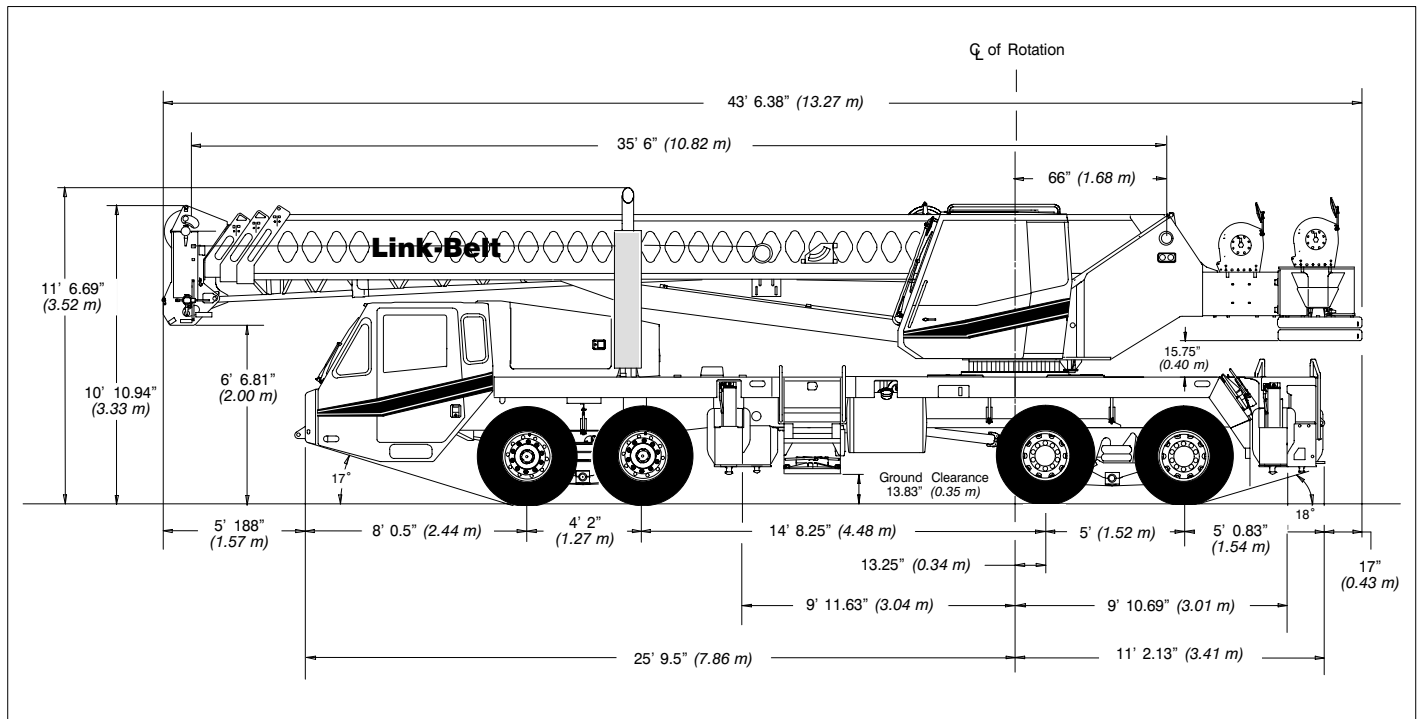

Turning radius	ft-in	meters
Wall to wall over carrier	44' 1"	13.4
Wall to wall over boom	45' 6"	13.9
Wall to wall over boom attachment	46' 11"	14.3
Centerline of tire	38' 7"	11.8
Tail Swing		
With counterweight	12' 8.5"	3.9
Without counterweight	12' 5.25"	3.8

Boom, Attachments, and Upperstructure

■ Boom

Design – Four section, box type construction of high tensile steel consisting of one base section and three telescoping sections. The vertical side plates have diamond shaped impression for superior strength to weight ratio. The first telescoping section extends independently by means of one double-acting, single stage hydraulic cylinder with integrated holding valves. The second and third telescoping sections extend proportionally by means of one double-acting, single stage cylinder with integrated holding valves and cables.

- 35.5 to 110 ft (10.8 to 33.5 m) four-section full power boom
- Two mode boom extension: A-max mode provides superior capacities by extending the first telescope section to 60.3 ft (18.4 m). Standard mode synchronizes all the telescoping sections proportionally to 110 ft (33.5 m). Controlled from operator's cab.
- Mechanical boom angle indicator
- Maximum tip height for A-max mode is 68.8 ft (21.0 m) and standard mode is 117.4 ft (35.8 m).

Boom Head

- Four 16.5 in (41.9 cm) root diameter nylon sheaves to handle up to eight parts of line
- Easily removable wire rope guards
- Rope dead end lugs on each side of the boom head
- Boom head is designed for quick reeve of the hook block

Boom Elevation

- One double acting hydraulic cylinder with integral holding valve
- Boom elevation: -3° to 78°

Auxiliary Lifting Sheave – Optional

- Single 16.5 in (41.9 cm) root diameter nylon sheave
- Easily removable wire rope guard
- Does not affect erection of the fly or use of the main head sheaves.

Hook Blocks and Ball – Optional

- 40-ton (36.3 mt) 4 sheave quick-reeve hook block with safety latch
- 50-ton (45.4 mt) 5 sheave quick-reeve hook block with safety latch
- 8.5-ton (7.7 mt) swivel and non-swivel hook balls with safety latch

Fly – Optional

- 28.5 ft (8.7 m) one piece lattice fly, stowable, offsettable to 2°, 20° and 40°. Maximum tip height is 144.8 ft (44.1 m).
- 28.5 to 51 ft (8.7 to 15.5 m) two piece bi-fold lattice fly, stowable, offsettable to 2°, 20° and 40°. Maximum tip height is 166.9 ft (50.9 m).

■ Cab and Controls

Environmental Ultra-Cab™ – Fully enclosed, one person cab of composite structure with acoustical insulation.

Equipped with:

- Tinted and tempered glass windows
- Extra-large fixed front window with windshield washer and wiper
- Swing up roof window with windshield wiper
- Sliding left side door with large fixed window
- Sliding rear and right side windows for ventilation
- Six way adjustable, hydraulically cushioned seat with seat belt and storage compartment
- Engine dependent warm-water heater with defroster nozzles for the front window and cab floor
- Bubble level
- Circulating fan
- Adjustable sun visor
- Dome light
- Cup holder
- Fire extinguisher
- Left side viewing mirror
- Pull-out Cabwalk™ – optional

Controls – Two dual axis hydraulic joystick controllers or two optional single axis hydraulic controllers for:

- Swing
- Boom hoist
- Main rear winch
- Warning horn button
- Auxiliary front winch – optional
- Drum rotation indication
- Winch high/low speed and disable switch
- Telescopic override switch

Overhead console mounted controls and indicators for:

- Engine ignition
- Engine throttle lock
- Drum rotation indicator
- Front windshield wiper and washer
- Cab floodlights
- Warning horn
- Function disable
- Swing park brake
- Air conditioning – optional
- Boom floodlight – optional
- Third wrap indicators – optional

Outriggers controls – Hand held control box with umbilical cord gives the operator the freedom to look about while setting the outriggers.

Foot controls for:

- Boom telescope
- Swing brake
- Engine throttle

Cab Instrumentation – Ergonomically positioned analog instrumentation for crane operation including:

- Check and stop engine indicators
- Engine coolant temperature with warning indicator
- Hydraulic oil temperature with warning indicator
- Engine oil pressure with warning indicator
- Voltage indicator with warning indicator
- Fuel level
- Tachometer

Rated Capacity Limiter (RCL) – Micro-guard 434 graphic audio-visual warning system built into the dash with anti-two block and function limiter. Operating data available includes:

- Machine configuration
- Boom length and angle
- Head height
- Allowed load and % of allowed load
- Boom angle
- Radius of load
- Actual load

Presetable defined area alarms include:

- Maximum and minimum boom angles
- Maximum tip height
- Maximum boom length
- Swing left/right positions

Internal RCL light bar – Optional

Visually informs the operator when crane is approaching maximum load capacity with a series of green, yellow, and red lights.

External RCL light bar – Optional

Visually informs the ground crew when crane is approaching maximum load capacity with three lights (green, yellow, and red).

■ Swing

Bi-directional hydraulic swing motor mounted to a planetary reducer for 360° continuous smooth swing at 2.5 rpm

Swing park brake – 360°, electric over hydraulic, (spring applied/hydraulic released) multi-disc brake mounted on the speed reducer. Operated by a toggle switch from the operator's cab.

Swing brake – 360°, foot operated, hydraulic applied disc brake mounted to the speed reducer

Swing lock – Two position house lock (boom over front and rear) operated from the operator's cab

360° positive swing lock – Optional

Meets New York City requirement

■ Electrical

Swing Alarm – Audio warning device signals when the upper is swinging.

Lights

- Two working lights on cab front
- One rotating amber beacon on top of the cab – optional
- One amber strobe beacon on top of the cab – optional

■ Hydraulic System

Counterbalance Valves – All hoist motors are equipped with counterbalance valves to provide load lowering and prevents accidental load drop when hydraulic power is suddenly reduced.

■ Load Hoist System

2M Main and Auxiliary (Optional) Winches

Axial piston, fixed and half displacement (2-speed), motors driven through planetary reduction unit for positive control under all load conditions.

- Grooved lagging
- Power up/down mode of operation
- Drum rotation indicator
- Drum diameter: 11 in (27.9 cm)
- Rope length: 550 ft (167.6 m)
- Hoist drum cable follower – optional
- Third wrap indicator – optional

■ Load Hoist System - continued

Rope Layer	Maximum Line Pull	Normal Line Speed	High Line Speed	Layer	Total
	lb (kg)	ft/min (m/min)	ft/min (m/min)	ft (m)	ft (m)
1	15,519 (7 039.3)	163 (49.7)	327 (99.7)	97 (29.6)	97 (29.6)
2	14,037 (6 367.1)	181 (55.2)	361 (110.0)	107 (32.6)	205 (62.5)
3	12,814 (5 812.3)	198 (60.4)	396 (120.7)	118 (36.0)	322 (98.1)
4	11,787 (5 346.5)	215 (65.5)	460 (131.1)	128 (39.0)	450 (137.2)
5	10,912 (4 949.6)	232 (70.7)	465 (141.7)	138 (42.1)	589 (179.5)
6	10,158 (4 607.6)	250 (76.2)	499 (152.1)	148 (45.1)	737 (224.6)

Wire Rope Application		Diameter		Type	Max. Permissible Load	
		in	mm		lbs	kg
Main (Rear) Winch	Standard	5/8	16	6 x 19 IWRC - right regular lay (Type DB)	11,770	5 338.8
	Optional	5/8	16	18 x 19 rotation resistant right (Type RB)	9,080	4 118.6
Auxiliary (Front) Winch	Standard	5/8	16	6 x 19 IWRC - right regular (Type DB)	11,770	5 338.8
	Optional	5/8	16	18 x 19 rotation resistant - right regular lay (Type RB)	9,080	4 118.6

■ Counterweight

Standard – 11,500 lbs (5 216.3 kg) total counterweight consisting of two, hydraulically removable 3,600 lbs (1 632.9 kg) counterweights with capacities for 4,300 lbs (1 950.4 kg) and 7,900 lbs (3,583.4 kg) counterweight configurations. Assembled and disassembled by hydraulic cylinders controlled from both sides of the upper structure.

Optional – 3,600 lbs (1 632.9 kg) in addition to standard counterweight for a total of 15,100 lbs (6 849 kg).

Counterweight Usage Combinations	Standard			Optional
	4,300 lbs (1 950 kg)	7,900 lbs (3 583 kg)	11,500 lbs (5 216 kg)	15,100 lbs (6 849 kg)
1		X	X	X
2			X	X
3				X

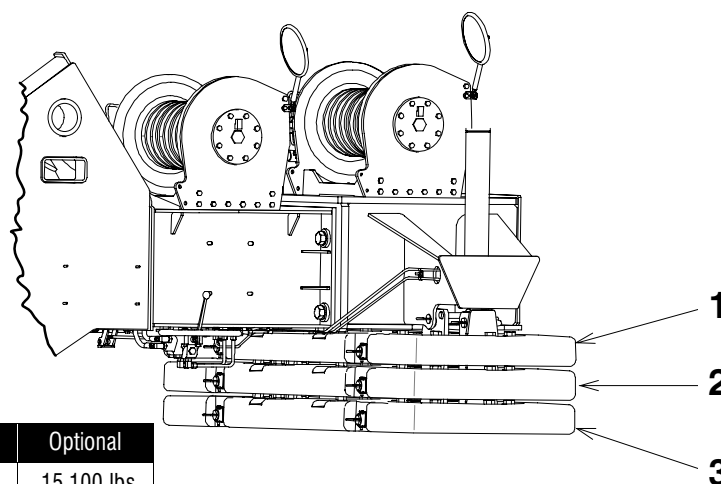

Carrier

■ General

8 ft – 6 in (2.6 m) wide, 286.25 in (7.27 m) wheelbase (centerline of first axle to fourth axle)

Frame – Box–type, torsion resistant, welded construction made of high tensile steel. Equipped with three weather–proof storage compartments, front and rear towing and tie–down lugs, tow connections, and access ladders.

■ Outriggers

Boxes – Two double box, front and rear welded to the carrier frame

Beams and Jacks – Four single stage beams with Confined Area Lifting Capacities (CALC™) provide selectable outrigger extensions of full, intermediate and retracted. Hydraulically controlled from the operator's cab and on both sides of chassis with integral check valves. A fifth front bumper outrigger is hydraulically controlled from the operator's cab and at the front bumper of carrier with integral check valve.

Pontoons – Four lightweight, quick release “stow 'n go” 23.5” x 27.25” (59.7 cm x 69.2 cm) hexagonal steel pontoons with a contact area of 427 in² (2 754.8 cm²) can be stored on the main outrigger jacks for road travel or in storage racks on the carrier. The fifth is a self stowing 14.75 inch (37.5 cm) diameter steel pontoon with a contact area of 171 in² (1 102.6 cm²).

Main Jack Reaction – 74,400 lbs (33 747.3 kgs) force and 174.2 PSI (1 201.3 kPa) ground bearing pressure

■ Steering and Axles

Sheppard full integral dual hydraulic steering, mechanical steering of the front tandem axles

Drive – 8 x 4 for on/off–highway travel

Axle 1 & 2 – Tandem steered, non–driven

Axle 3 & 4 – Tandem non–steered, driven with reduction: 5.43

Inter–Axle Differential Lock – Traction adding device that locks axle 3 with axle 4. Operated by a rocker switch from the carrier cab

■ Suspension

Raydan Air Link™ walking beam air suspension with height adjustment. The rear of the chassis can be lowered by rocker switch in the carrier cab.

- **Axle Lift System – Optional**
Improves rear tire ground clearance when the crane is up on its outriggers

■ Tires and Wheels

Front – Four (single) 425/65R22.5 tires on aluminum disc wheels

Rear – Eight (dual) 11R22.5 tires on aluminum outer and steel inner disc wheels

- Spare tires and wheels – optional
- Tire inflation kit – optional

■ Brakes

Service – Full air brakes on all wheel ends. Dual circuit compressed air system with air dryer.

Parking/Emergency – Spring loaded type, acting on 3rd and 4th axles automatically apply when air pressure drops below 40 PSI (275.8 kPa) in both circuits.

■ Electrical

Three batteries provide 12–volt operation and starting.

Lights

- Front lighting includes two main headlights, two high beams lights, two parking/directional indicators, and three cab marker lights.
- Side lighting includes three parking/directional indicators per side.
- Rear lighting includes two parking/directional indicators, two parking/brake lights, two reversing lights, three marker lights, and a license plate light.
- Other equipment includes hazard/warning system, cab light, instrument panel light, and signal horn.
- One amber strobe beacon on top of the cab – optional
- Daytime running lights – optional

■ Engine

Caterpillar C-10	
Number of cylinders	6
Cycle	4
Bore and stroke: in (mm)	4.9 x 5.5 (125 x 140)
Piston displacement: in3 (l)	629 (10.3)
Maximum brake: hp (kW)	335 (249.8) @2,100 rpm
Peak torque: ft-lb (J)	1,250 (1 695) @ 1,200 rpm
Alternator: volt - amps	12 - 145
Crankcase capacity: qts. (l)	22 (21)
<ul style="list-style-type: none"> • Cruise control • Three-stage engine compression brake • Hydro-statically driven fan and thermostatically controlled radiator • 120 V engine block heater • Ether injection system - optional 	

■ Transmission

Automated – ZF Astronic is an automated (no clutch pedal) manual transmission with 12 forward gears and 2 reverse gears.

■ Fuel Tank

One 75 gallon (283.9 l) capacity tank

■ Hydraulic System

Main Pumps

- Four fixed displacement gear pumps for the main and auxiliary winches, swing, boom hoist, and telescope with automatic disconnect when crane is in travel mode
- One fixed displacement gear pump for steering and the fifth outrigger
- Two fixed displacement gear pumps for engine cooling fan and main outriggers. These pumps also provide flow to the winches and boom hoist for “pick and carry” mode. Operated by a rocker switch in the carrier cab.
- Combined pump capacity of 190 gpm (719.2 lpm)
- Hydraulic oil cooler is integrated into the engine radiator.

Hydraulic Reservoir – 144 gallons (545 l) capacity equipped with sight level gauge. Diffusers built in for deaeration.

Filtration – One 10 micron, full flow, line filter in the control circuit. All oil is filtered prior to return to sump tank. Accessible for easy filter replacement.

■ Pump Drive

All functions are hydraulically powered allowing positive, precise control with independent or simultaneous operation of all functions.

■ Cab and Controls

Environmental Ultra–Cab™ – Fully enclosed, one person cab of composite structure with acoustical insulation. Equipped with:

- Tinted and tempered glass windows
- Roll down left side window for ventilation
- Sliding rear and right side windows for ventilation
- Windshield washer and wiper
- Six way adjustable and air suspended driver's seat with safety belt
- Two adjustable rear–view mirrors
- Engine dependent warm–water heater with defroster nozzles for windshield and cab floor
- Adjustable sun visor
- Dome light
- 12 volt connection
- Fire extinguisher

Cab and Controls – *continued*

Cab Instrumentation – Ergonomically positioned analog instrumentation for driving including:

- Speedometer with odometer, hourmeter, and trip odometer
- Front and rear air pressure with warning indicator
- Engine coolant temperature with warning indicator
- Engine oil pressure with warning indicator
- Voltage indicator with warning indicator
- Fuel level
- Tachometer

Dash mounted controls and indicators

for:

- Check and stop engine indicators
- Windshield wipers and washers
- Carrier lights and turn indicators
- Transmission controls

- Carrier/upper throttle control
- Engine cooling fan override
- Cruise controls
- Engine compression brake controls
- Cab heater
- Console dimmer switch
- Engine diagnostic switch
- Warning lamps
- Engine ignition
- Air conditioning – optional

Foot controls for:

- Carrier service brakes
- Engine throttle

■ Additional Equipment

Standard:

- Adjustable boom rest
- Aluminum full deck fenders with mud flaps
- Left and right bubble levels
- Air hose connection ports
- Clearance flaps

Optional:

- Pneumatic and electrical quick disconnect connectors mounted on the rear for trailer or boom dolly brakes and lights
- Left side aluminum storage box
- Rear mounted pintle hook
- Spare tires and wheels
- Tire inflation system

■ Carrier Speeds and Gradeability *(ZF Astronic)*

Gear	12	11	10	9	8	7	6	5	4	3	2	1	Rev 1	Rev 2	1st @ creep	Rev @ creep	
Ratio	0.78	1.00	1.27	1.63	2.10	2.70	3.55	4.57	5.78	7.44	9.59	12.24	11.41	8.88	12.24	11.41	
Speed	mph	60.13	46.78	36.92	28.72	22.27	17.33	13.17	10.25	8.09	6.29	4.88	3.80	4.10	5.27	1 - 1.3	1.6 - 2.1
	km/hr.	96.8	75.3	59.4	46.2	35.8	27.9	21.2	16.5	13.0	10.1	7.9	6.1	6.6	8.5	1.1 - 1.4	1.8-2.3
Gradeability *	2.3	3.4	4.7	6.4	8.5	11.2	15.0	19.5	24.8	32.1	41.6	53.7	49.7	38.5	26.7	24.7	

* – Peak torque; 1,250 ft–lb. (1 695 J) @ 1,200 rpm.

■ Axle Loads

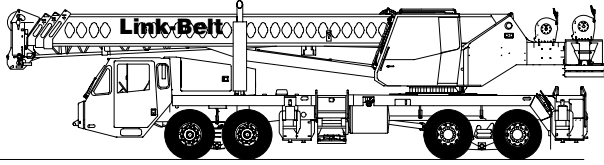

Base machine with full tank of fuel and 4,300 lbs. (1 950 kg) of counterweight	G.V.W. [□]		Upper Facing Front			
	lbs	kg	Front Axle		Rear Axle	
			lbs	kg	lbs	kg
	64,075	29 064	29,201	13 245	34,874	15 819
Driver in the carrier cab	200	91	262	119	-62	-28
Rear pintle hook	25	11	-10	-5	35	16
Pneumatic and electrical connectors for trailer and boom dolly	7	3	2	1	5	2
Carrier aluminum storage box	57	26	16	7	41	19
Axle lift system - rear axles	48	22	1	1	47	21
Air conditioning - carrier cab	124	56	157	71	-33	-15
Hoist drum cable follower - main	93	42	-41	-19	134	61
Auxiliary winch with 550 ft. (167.6 m) of 5/8 in (16 mm) type DB rope	423	192	-101	-46	524	238
Hoist drum cable follower - auxiliary	93	42	-41	-19	134	61
Remove 550 ft. (167.6 m) rope (main) winch	-405	-184	154	70	-559	-254
Remove 550 ft. (167.6 m) rope (auxiliary) winch	-405	-184	154	70	-559	-254
Pull-out Cabwalk™	50	25	12	5	38	17
Air conditioning - operator's cab	315	143	4	2	311	141
360° mechanical swing lock (meets New York City requirements)	60	27	6	3	54	24
One slab of counterweight on upper	3,636	1 647	-1,394	-631	5,026	2 280
Two slabs of counterweight on upper	7,264	3 295	-2,788	-1 265	10,052	4 560
Three slabs of counterweight on upper	10,896	4 942	-4,183	-1 897	15,079	6 840
Floodlight to the front of the boom base section	10	5	15	7	-5	-2
Fly mounting brackets to boom base section for fly options	99	45	87	39	12	5
28.5 ft (8.7 m) Offsettable lattice fly (stowed)	1,238	562	1,312	595	-74	-34
28.5-51 ft (8.7 - 15.5 m) Offsettable lattice fly (stowed)	1,830	830	1,810	821	20	9
Auxiliary lifting sheave	91	41	165	75	-74	-34
40-ton (36.3 mt) 4-sheave hook block at boom head	780	354	1,360	617	-580	-263
50-ton (45.4 mt) 5-sheave hook block at boom head	1,090	494	1,901	862	-811	-368
8.5-ton (7.7 mt) hook ball at boom head	360	163	641	291	-281	-127

Counterweight load transfer	Front		Rear	
	lbs	kg	lbs	kg
Transfer one slab of counterweight to carrier deck	4,148	1 882	-4,148	-1 882
Transfer two slabs of counterweight to carrier deck	8,296	3 763	-8,296	-3 763
Transfer three slabs of counterweight to carrier deck	12,444	5 645	-12,444	-5 645

□ Adjust gross vehicle weight & axle loading according to component weight. Note: All weights are ± 3%

Axle	Max. Load @ 65 mph. (105 km/h)
Front	45,400 lbs (21 047 kg) - aluminum disc wheels with 425/65R22.5 tires
Rear	45,400 lbs (21 047 kg) - aluminum disc wheels with 11R22.5 tires

This Page Intentionally Blank

