

Mast - Reactions

□ 18 ft

▲ 131 ft → 262 ft

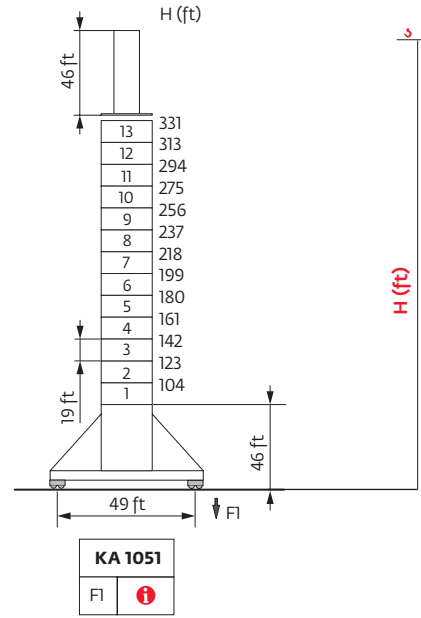
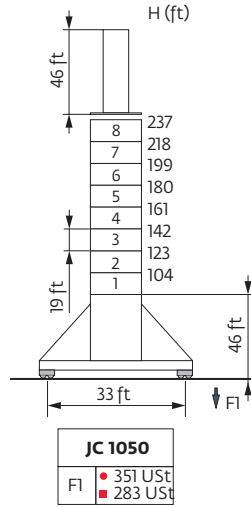
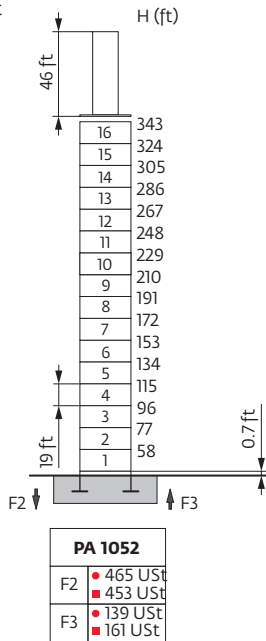

For any special request, please consult us.

Mounting possibilities ⓘ

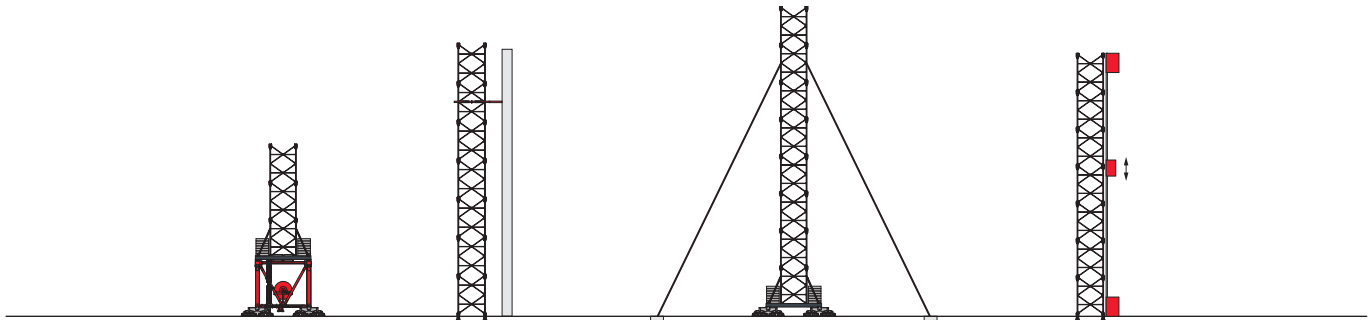

Mechanisms

480 V - 60 Hz														hp	kW	
	320 LVF 100 Optima	44.1 USt	fpm	220	282	387	486	531	112	141	197	243	266	320	240	1,745 ft
		USt		22	16.5	11	7.5	6.6	44.1	33.1	22	15.7	14			
	320 LVF 160 Optima	70.5 USt	fpm	121	161	230	361	351	62	79	115	180	177	320	240	2,103 ft
		USt		35.3	26.5	17.6	8.8	9.4	70.5	52.9	35.3	17.6	19.3			
	15 DVF 16	44.1 USt	fpm	0 → 108 (44.1 USt) 0 → 164 (22 USt) 0 → 220 (11 USt) 0 → 328 (2.8 USt)				15	11							
	25 DVF 30	70.5 USt	fpm	0 → 82 (70.5 USt) 0 → 164 (35.3 USt) 0 → 295 (17.6 USt) 0 → 377 (8.8 USt)				25	18.5							
	RVF 194 Optima+		rpm	0 → 0.6				4 x 15	4 x 11							

IEC 60204-32	kVA
480 V (+6% -10%) 60 Hz	320 LVF / 15 DVF: 303 → 175 kVA 320 LVF / 25 DVF: 311 → 183 kVA

These mast combinations meet the EN 14439 and ASME B30.3-2016 specifications for "out of service" wind conditions, provided the illustrated wind speed matches required design wind speed for the location of the tower crane. The "out of service" design wind speed was determined in accordance with ASCE 7-10, Figure 26.5-1A. The wind velocity, used for this configuration was 98 mph (158 kph), which represents a nominal design 3-second wind gust at 33 ft (10 m) above ground for Exposure B category. A factor of 0.85 was applied to the 700-year ultimate design wind speed of 115 mph (185 kph), per ASCE 37-02, with the assumption that this crane is considered a temporary structure used during a construction period of 2 years or less.

- Standard equipment
- Options
- Reactions in service
- Reactions out of service
- Hoisting
- Trolleying
- Slewing
- Travelling
- Required power
- Power Control Function: winch speeds adapted to the available power

This commercial document is not legally binding. For any technical information, please refer to the corresponding instructions.

