

data

model 21000

product guide

features

- 756 mton (834 ton) Base Capacity
- 5 381 mton-m (38,920 ft-kips) Maximum Load Moment
- 109,7 m (360') Heavy-Lift Boom
- 121,9 m (400') Long-Reach Boom
- 195,1 m (640') Luffing Jib
- 448 kW (600 HP) engine
- EPIC® controls
- 161 m/min (529 fpm) line speed
- 217 kN (48,800 lb) line pull
- MAX-ER™ Attachment
907-mton (1,000-ton) capacity
453-mton (500-ton) luffing jib capacity
- OCTA-TRAC® Eight crawler system
Optional narrow 9,14 m (30') stance
- Simplified shipment, modular design
- Heaviest module weighs 43 094 kg (95,000 lb)
Maximum module width 3,95 m (13')
- Manitowoc CraneCARE™ comprehensive support



contents

Specifications	3
Outline Dimensions	7
Transport / Assembly	14
Performance Data	17
Boom Combinations	20
Main Boom Range / Load Charts	22
Long-Reach Boom Range / Load Charts	24
MAX-ER™ Outline Dimensions	26
MAX-ER™ Performance Data	29
MAX-ER™ Boom Combinations	31
MAX-ER™ Main Boom Range / Load Charts	33
MAX-ER™ Luffing Jib Range / Load Charts	35
CraneCARE™	39

	Specifications	Outline Dimensions/Weights	Wire Rope Lengths	Wire Rope Specifications	Boom Combinations	Range Diagram/Capacity Charts
No. 21000 Basic Crane	3-6	7-8				
Engine(s)	3					
Hydraulic System	3					
Drums & Laggings	3, 19					
Mast Hoist	3					
Boom Hoist	4, 19					
Swing System	4					
Boom Support System	4	10				
Counterweights	4					
Operator's Cab	4					
Carbody	6	9				
Crawlers	6	9				
Optional Equipment						
Boom point	4, 5	13				
Hook block/weight ball	4,5,6					
Miscellaneous	6					
Working Weights	18					
Transport/Assembly	14-16					
CraneCARE SM	39-40					
Mast No. 81 (also Boom No. 81)		11				
Heavy-Lift No. 80	4	11-12	17	19	20	22-23
Heavy-Lift No. 80 with No. 81 Luffing Jib - PENDING	5	12-13		19		
Long Reach No. 80-81	5	12	18	19	21	24-25
MAX-ER	5	26-28				
Heavy-Lift No. 80			29	19	31	33-34
Heavy-Lift No. 80 with No. 81 Luffing Jib			30	19	32	35-38
Long Reach No. 80-81 - PENDING						

specifications

3

Upperworks



Engine

Cummins Model QSK19-C600 diesel, 6 cylinder, 450 kW (600 BHP) @ 2100 governed RPM.

Optional: other engines of equivalent performance.

Includes engine block heater (120 V), ether starting aid, disconnect clutch for cold weather starting, high silencing muffler, hydraulic oil cooler, radiator and fan.

Multiple hydraulic pump drive transmission provides independent power for all machine functions.

Two 12 volt maintenance-free, Group 8D batteries, 1155 CCA at -18°C (0° F), 24 volt starting and 120 amp alternator.

One 927 l (245 gal) capacity diesel fuel tank, mounted in rear of upperworks, with level indicator in operator's cab.

Optional: Cold-weather package with heater for fluids, brake pedals, batteries, and computer display.



Controls

Modulating electronic-over-hydraulic controls provide infinite speed response directly proportional to control lever movement. Controls include Manitowoc's exclusive EPIC® *Electronically Processed Independent Control* system providing microprocessor driven control logic, pump control, on-board diagnostics, and service information.

Block-up limit control is standard for hoist and auxiliary lines.

Integrated Load Moment Indicator system (LMI) is standard for main boom. "Function cut-out" or "warning only" operation is selected via a keyed switch on the LMI console. Includes travel and swing alarms.

Optional: Upper boom point assembly with LMI.

Optional: Anemometer (wind indicator).



Hydraulic System

Twelve high-pressure piston pumps, driven by a multi-pump transmission, provide independent closed-loop hydraulic power for the hoisting drums, mast hoist, boom hoist, swing, and crawlers.

A gear pump provides power for jacks, pin pullers, and other accessories.

Hydraulic reservoir has 719 l (190 gal) capacity and is equipped with breather, cleanout access, filters, and internal diffuser.

Each function is equipped with relief valves to protect the hydraulic circuit from overload or shock.

System includes oil cooler and replaceable spin-on and full flow filters. All oil is filtered twice: at the reservoir and before entering the hydraulic pumps.

System	Pumps	kg/cm ² (psi)	lpm (gpm)
Front Hoist Drum	2	422 (6,000)	379 (100)
Rear Hoist Drums*	2	422 (6,000)	379 (100)
Boom Hoist	2	422 (6,000)	303 (80)
Swing	2	422 (6,000)	303 (80)
Left Crawlers (also diverts for luffing drum)	2	422 (6,000)	303 (80)
Right Crawlers (also diverts for mast hoist)	2	422 (6,000)	303 (80)
Accessory System	1	211 (3,000)	95 (25)
Optional MAX-ER jacking	1	211 (3,000)	246 (65)

*Also powers optional boom-butt-mounted hoist drum.



Drums

Basic crane is equipped with front and rear hoist drums, each 1 780 mm (65-1/2") wide, 660 mm (26") diameter, and grooved for 32 mm wire rope.

Front drum is mounted on front section of rotating bed. Rear drum is mounted on rear section. Each end of each drum is driven by a variable-displacement hydraulic motor and a planetary reduction gear box equipped with bi-directional brake.

Drum rotation indicator is standard for each drum.

Hoists include 32 mm wire rope.

Optional: Hydraulically powered auxiliary drum mounted in boom butt. Uses 1-1/8" wire rope with a line pull of 144 kN (32,300 lb).

Optional: Hydraulically powered auxiliary/luffing drum mounted on rear section of rotating bed. Same dimensions and specifications as main hoisting drums.



Mast Hoist

Dual-drum mast hoist mounted in rear section of rotating bed is powered by a variable-displacement hydraulic motor and a planetary reduction gear box with internal brake. Ratcheting pawl standard. Includes mast-hoist wire rope. Each drum equipped with lagging 508 mm (20") wide and 584 mm (23") diameter.

model 21000



specifications



Boom Hoist

4 Independent boom hoist, mounted in mast butt, has grooved drum 1 397 mm (55") wide and 787 mm (31") diameter.

Drum is powered by two variable-displacement hydraulic motors coupled to integral brakes and planetary reduction gearboxes. Ratcheting pawl, rotation indicator, pressure roller, and wire rope for reeving 20-part boom hoist line are standard.



Swing System

High strength fabricated steel alloy rotating bed is mounted on 3,40 m (11' 2") diameter triple-row roller bearing.

The rotating bed is composed of front and rear sections joined with FACT™ alignment, four power-actuated pins, and H-FACT® hydraulic quick coupler system. The front section is equipped with a hoist drum and the power plant. The rear section includes a second hoist drum, gantry, and mast hoist.

Independent swing is powered by two swing drives, each composed of a fixed-displacement hydraulic motor coupled to a planetary reduction gearbox with internal brake. 360° positive swing lock is standard.

Swing system maximum speed: 1.0 rpm.



Boom Support System

Gantry

The 8,5 m (28') long retractable gantry provides the geometry to raise the stationary mast. Gantry top is connected to mast-hoist equalizer by 12-part reeving. Equalizer is connected to mast top by high-strength steel straps. The gantry's telescoping backhitch is equipped with power actuated locking pins.

Mast

Stationary No. 81 lattice mast provides geometry to raise and support all boom lengths. 30,5 m (100') mast standard for basic crane; 42,7 m (140') mast required for MAX-ER® applications. Boom-hoist rope reeved from drum in mast butt through sheaves in mast top and boom-hoist equalizer forms 20-part boom-hoist rigging. High-strength steel straps connect equalizer to boom top.

Cushioned boom stop and automatic boom stop are standard.



Counterweight

QTY.	ITEM	UNIT WEIGHT		TOTAL WEIGHT	
		kg	lb	kg	lb
Upperworks					
1	Tray	11 657	25,700	11 657	25,700
28	Box	8 165	18,000	228 620	504,000
2	Railing	34	75	68	150
1	Platform	272	600	272	600
-	Pins & Hardware	103	250	103	250
Upperworks TOTAL		240 720	530,700		
Lowerworks					
2	Inner Box	24 268	53,500	48 536	107,000
2	Outer Box	21 092	46,500	42 184	93,000
Lowerworks TOTAL		90 720	200,000		
TOTAL		331 440	730,700		



Operator's Cab

Fully enclosed and insulated steel module is mounted at left front corner of rotating bed on a pivoting frame that permits cab to be repositioned for transportation or tilted for increased upward visibility.

Module is equipped with sliding door, large safety glass windows on all sides and roof. Signal horn, cab space heater, front and roof windshield wipers, dome light, sun visor and shade, fire extinguisher, air circulating fan, and air conditioning are standard.

Optional: Nylon protective window covers.

Attachments



No. 80 Heavy-Lift Boom

The liftcrane is equipped with No. 80 heavy-lift boom. 30,5 m (100') minimum length consists of a 9,1 m (30') butt, 12,2 m (40') insert, 6,1 m (20') transition insert, and 3,0 m (10') top with fifteen 762 mm (30") diameter roller bearing sheaves for 544-metric-ton (600-ton) maximum capacity. Rating can be increased to 756 metric-tons (831 tons) with optional boom point. Includes rope guides and boom angle indicator. Boom also includes 6,1 m (20') and 12,2 m (40') inserts to increase boom length to 109,7 m (360').

The No. 80 boom uses steel suspension straps and Manitowoc's patented, exclusive FACT™ connection system consisting of two vertical pins, two horizontal connection pins, and alignment pads for each boom connection location.

Liftcrane attachment includes 32 mm rotation resistant wire rope for two load lines, each 1 676 m (5,500').

Luffing jib preparation is standard.

specifications

5

Includes 544-metric-ton (600-ton) load block with duplex hook.

Optional: Detachable upper boom point with one 762 mm (30") diameter tapered roller bearing steel sheave with rope guard.

Optional: Two stabilizers to permit 360° swing when crawlers are in narrow configuration. Each fabricated steel stabilizer includes hydraulic leveling jack and a support pad. One stabilizer is mounted to each crawler beam. Stabilizers are controlled individually from hydraulic controls mounted to the stabilizer frame.



No. 80-81 Long-Reach Boom

Optional: No. 81 boom inserts and top. Used with components of No. 80 boom to form No. 80-81 long-reach boom. Minimum boom length, 54,9 m (180'); maximum length, 121,9 m (400'). Intermediate suspension required for No. 80-81 boom lengths of 103,6 m (340') or more.

No. 80-81 boom starts with components of No. 80 boom, finishes with components of No. 81 boom.

No. 81 components include: 6,1 m (20') and 12,2 m (40') straight inserts; 6,1 m (20') tapered insert (for transition from No. 80 to No. 81 boom); 6,1 m (20') straight transition insert for transition from pin-type FACT™ connectors on tapered insert to hook-type FACT™ connectors on No. 81 inserts; 9,1 m (30') No. 81 boom top; steel rigging straps; wire rope guide; and LMI hardware.



No. 81 Luffing Jib

Optional: 91,4 m (300') No. 81 luffing jib, for use on No. 80 boom, either with basic Model 21000 or with MAX-ER attachment.

No. 81 luffing jib uses inserts, top, and rigging components from No. 81 boom. Luffing jib butt is used only in luffing jib.

Luffing jib attachment includes 23,0 m (75' 5") No. 481 main strut with 11 sheaves, 24,6 m (80' 8") No. 481 jib strut with 11 sheaves, main-strut backstay straps, jib-support straps, 32 mm diameter wire rope for 22-part reeving between the struts, and LMI hardware.

Optional: Third drum on rear section of rotating bed is used for luffing.

Minimum length, 36,6 m (120'); maximum length, 91,4 m (300').

Luffing jib attachment includes dolly to support jib point during jackknife erection and lowering.

Uses same upper boom point as No. 80 or No. 80-81 boom.

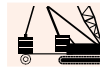

MAX-ER™

The MAX-ER™ attachment boosts the 21000's maximum capacity to 907 metric tons (1,000 tons).

Its components include:

One 12,2 m (40') No. 81 insert, added to increase mast length to 42,7 m (140').

Two additional swing drives (for a total of four) mounted on the rotating module. Each swing drive is powered by a fixed-displacement hydraulic motor coupled to a planetary reduction gearbox and internal brake.

A wheeled or hanging MAX-ER counterweight assembly attached to the top of the mast by steel straps and to the rear of the upperworks by shear-frame inserts.

The hanging MAX-ER counterweight is 17,9 m (58' 9") or 22,1 m (72' 6") behind the crane's centerline of rotation, and the wheeled MAX-ER counterweight is 18,0 m (59' 0") or 22,0 m (72' 0") behind the crane's centerline of rotation.

The wheeled counterweight uses large off-road tires, which can be positioned for traveling, crabbing, or swinging.

It also includes hydraulic support jacks and pads.

Wheeled Counterweight Assembly

ITEM	QTY	UNIT WEIGHT		TOTAL WEIGHT	
		kg	lb	kg	lb
Base / Wheel Assembly	1	42 524	93,750	42 524	93,750
Catwalk	1	726	1,600	726	1,600
Cylinder Support (Sub Assembly)	4	126	277	504	1,108
Hydraulic Cylinder	2	1 950	4,300	3 900	8,600
A-Frame	2	3 495	7,705	6 990	15,410
Counterweight					
Side Box	18	19 958	44,000	359 245	792,000
Center Box	4	19 958	44,000	79 832	176,000
Tray	1	15 381	33,910	15 381	33,910
Miscellaneous				736	1,622
				509 840	1,124,000

Hanging Counterweight Assembly

ITEM	QTY	UNIT WEIGHT		TOTAL WEIGHT	
		kg	lb	kg	lb
Sub Plate for Counterweight Tray	2	2 404	5,300	4 808	10,600
Cylinder Support (Sub Assembly)	4	126	277	504	1,108
Hydraulic Cylinder	2	1 950	4,300	3 900	8,600
A-Frame	2	3 495	7,705	6 990	15,410
Counterweight					
Side Box	20	19 958	44,000	399 160	880,000
Center Box	4	19 958	44,000	79 832	176,000
Tray	1	15 381	33,910	15 381	33,910
Miscellaneous				755	1,672
				511 330	1,127,300

specifications

A 544-mton (600-ton) load block with duplex hook.

6

Optional: 907-mton (1,000-ton) capacity duplex hook with roller thrust bearing and heavy-duty positive locking bar latches. Hook is used with the basic crane's 544-mton (600-ton) load block and the MAX-ER's standard 544-mton (600-ton) load block to provide 907-mton (1,000-ton) capacity.

Optional: Additional fifteen sheaves in No. 80 boom point. Required for 907-mton (1,000-ton) capacity.

Lowerworks



Carbody

Connects rotating bed and crawler assemblies. Fabricated steel rotating module is mounted to carbody module by 3,4 m (11' 2") diameter triple-row roller bearing.

Module is equipped with FACT connectors and powered pins.

For 9,1 m (30') "narrow" stance, crawler beams attach directly to carbody module.

For standard 14,5 m (47' 6") "wide" stance, two transverse carbody beams mount to the carbody module, and the crawler beams are then mounted to the transverse beams.



Crawlers

The 21000 uses Manitowoc's patented Octa-trac® eight-crawler travel system.

With Octa-trac, the left- and right-side crawlers each consist of two dual-crawler modules mounted at the ends of a connecting beam. The overall assembly measures 14,0 m (46' 0") long.

Each of Octa-trac's four dual-crawler modules has two parallel treads, each 4,95 m (16' 3") long and 1,22 m (4' 0") wide. Together, the two treads give each crawler module an overall width of 3,5 m (11' 6").

All eight treads are powered hydraulically, with the four right-side treads operating in unison, and the four left-side treads operating in unison.

Crawlers permit travel and counter-rotation with full rated load. Maximum travel speed, 1,1 kph (0.7 mph).

Crane Assembly Equipment

Portable engine-powered hydraulic unit to engage and disengage hydraulic connecting pins in the lowerworks; extend and retract the crawler beam hydraulic jacks; and extend and retract the boom cylinders. Various lifting slings and shackles, and counterweight tray handling pendants.

Optional Equipment

Optional: Blocks and Hooks, each with 762 mm (30") roller-bearing sheaves for 32 mm wire rope, a roller-bearing swivel hook, a hook latch, and a swivel lock.

23-mton (25-ton) swivel hook and weight ball

907-mton (1,000-ton) duplex hook assembly with roller thrust bearing, and heavy-duty positive locking bar latches. Can be used with one 544-mton (600-ton) block for up to 544-mton (600-ton) rating, or with two 544-mton (600-ton) blocks for higher capacities.

Optional: Wire rope for various applications.

Optional: Equipment and testing for special code compliance.

Optional: Hydraulic Test Kit: required to properly analyze the performance of the EPIC® control system.

Optional: Service Interval Kits: for the regularly scheduled maintenance of general crane operations.

Optional: Lighting Packages: consult dealer for available options.

Optional: Special paint colors other than Manitowoc standard red and black.

Optional: Custom vinyl decals of customer name and/or logo from artwork supplied by customer.

Optional: Export Packaging: basic crane, boom and jib sections. MAX-ER™ export packaging available.

outline dimensions

7

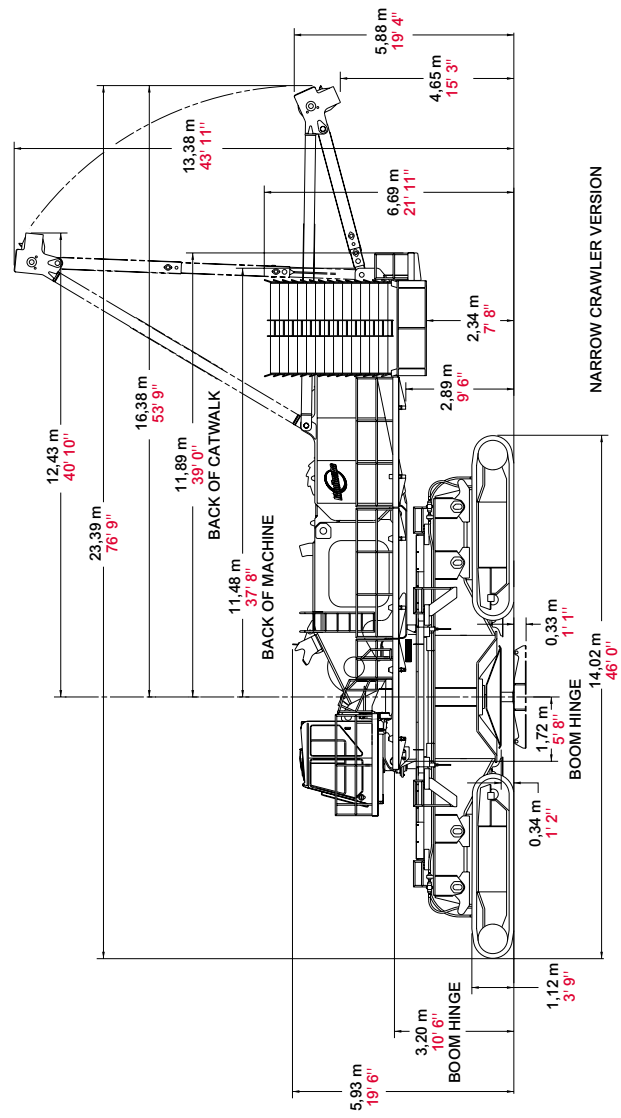
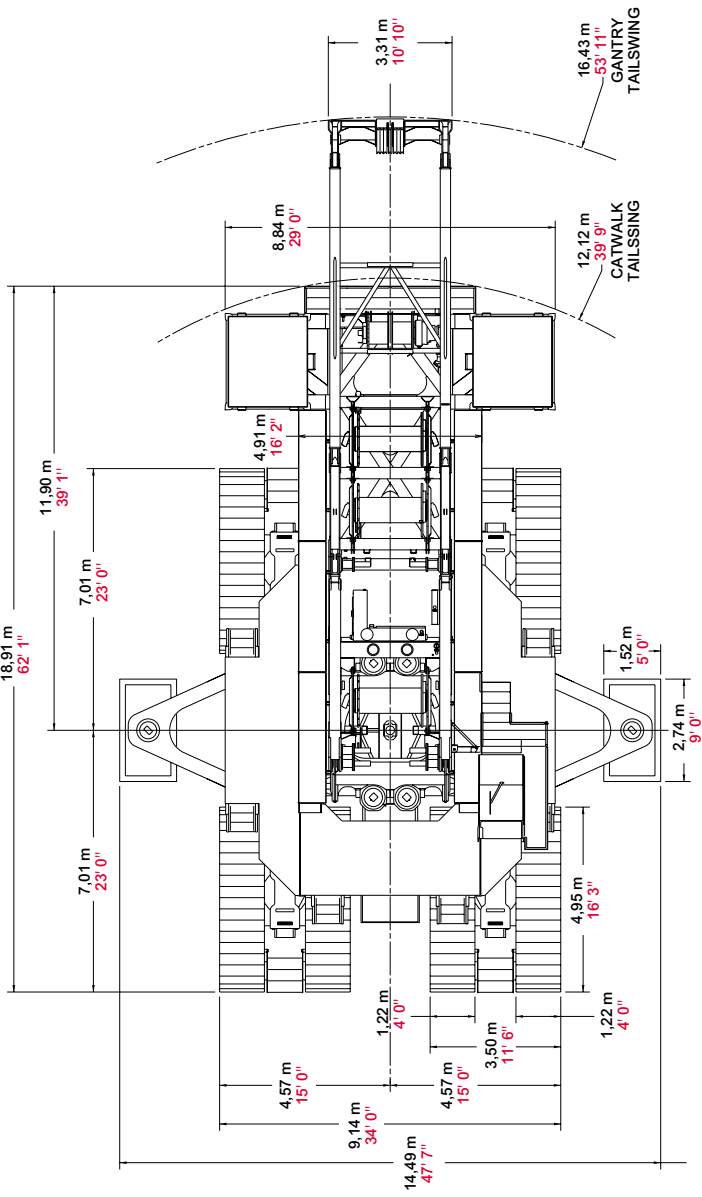
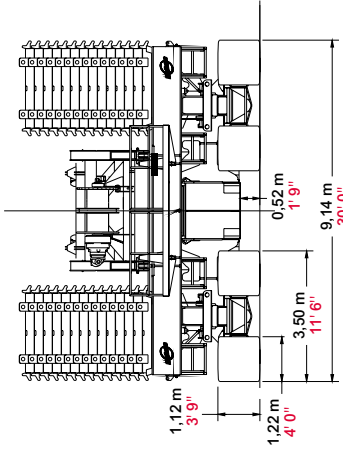
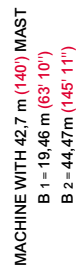
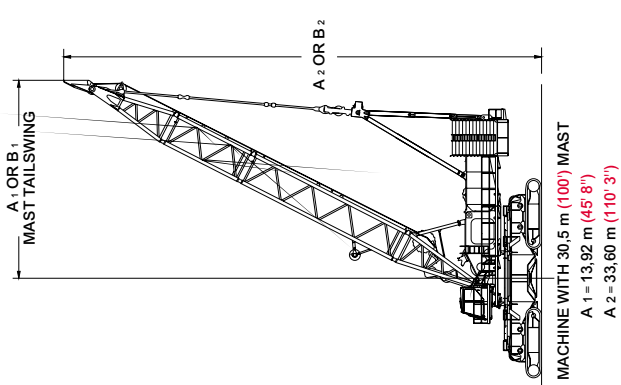

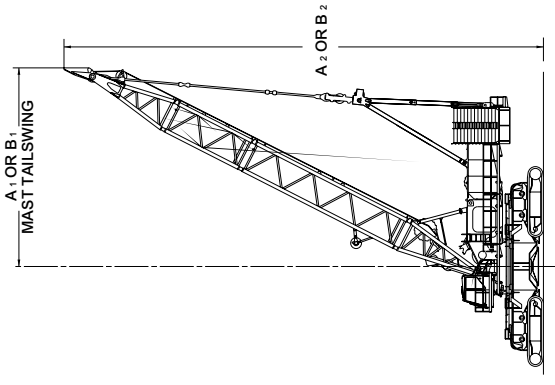
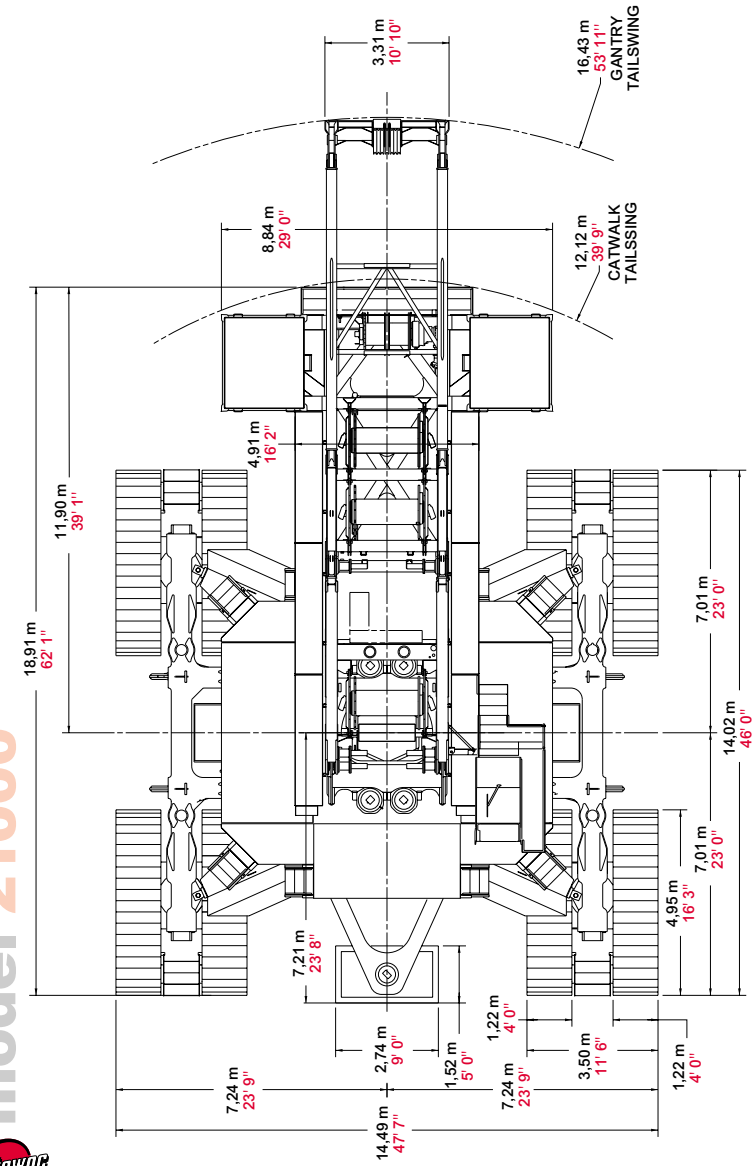

MACHINE WITH 30.5 m (100') MAST
 A₁ = 13,92 m (45' 8")
 A₂ = 33,60 m (110' 3")

MACHINE WITH 42.7 m (140') MAST
 B₁ = 19,46 m (63' 10")
 B₂ = 44,47 m (145' 11")

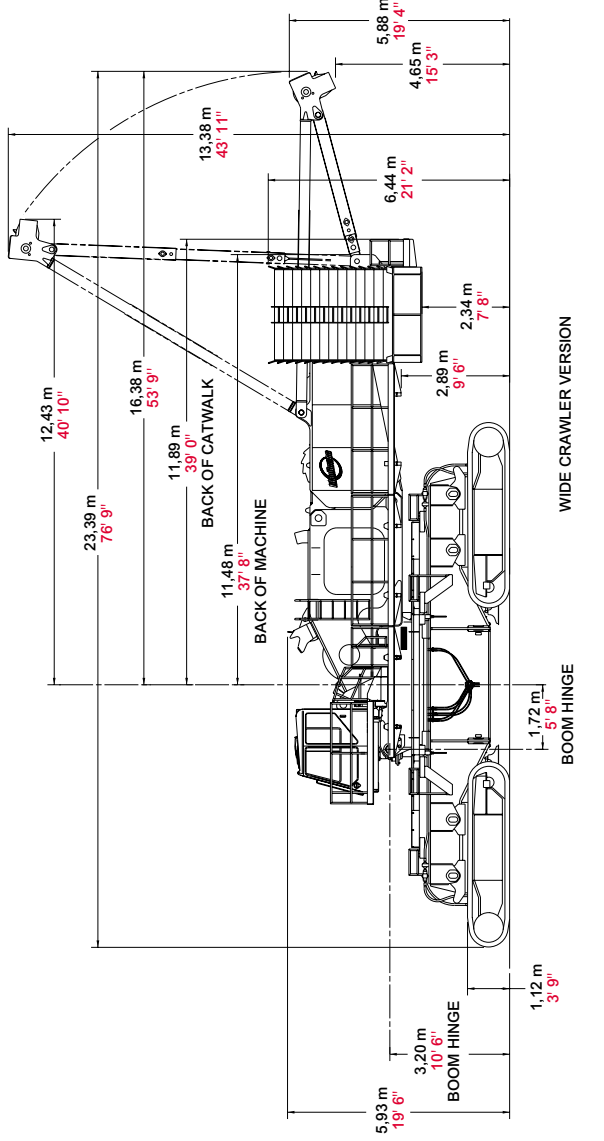

WIDE CRAWLER VERSION
 BOOM HINGE

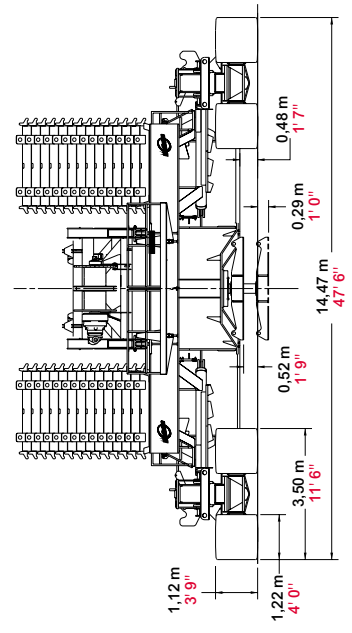

outline dimensions

outline dimensions

9

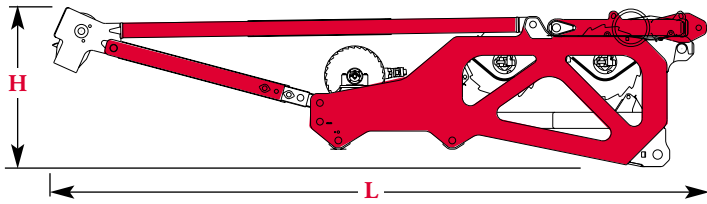

Rotating Bed - Rear Section x 1

Length	12,15 m	39' 11"
Width	3,31 m	10' 11"
Height	2,84 m	9' 4"
Weight	36 139 kg	79,675 lb

Note: Weight includes rotating bed rear section, gantry, mast hoist with wire rope, equalizer, second hoist drum with wire rope and optional luffing/auxiliary third hoist drum with wire rope.

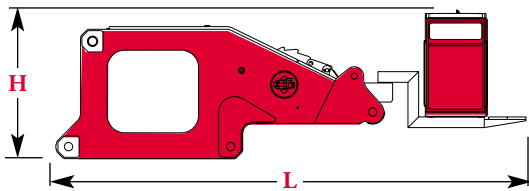

Rotating Bed - Front Section & Cab x 1

Length	8,95 m	29' 5"
Width	3,40 m	11' 2"
Height	2,51 m	8' 3"
Weight	42 984 kg	94,765 lb

Note: Weight includes rotating bed front section, first hoist drum with wire rope, diesel powerplant, operator's cab, full hydraulic fluid reservoir, and half tank of fuel.

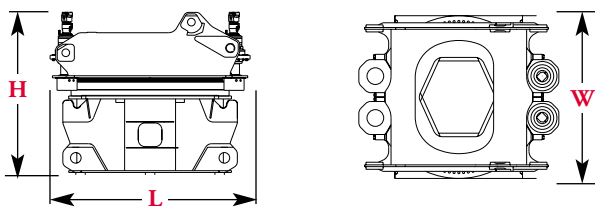

Carbody with Rotating Module & Two Swing Drives x 1

Length	4,31 m	14' 2"
Width	3,51 m	11' 6"
Height	4,11 m	13' 6"
Weight	42 456 kg	93,600 lb

Note: Two additional swing drives required for MAX-ER. Total additional weight for both is 1 678 kg (3,700 lb).

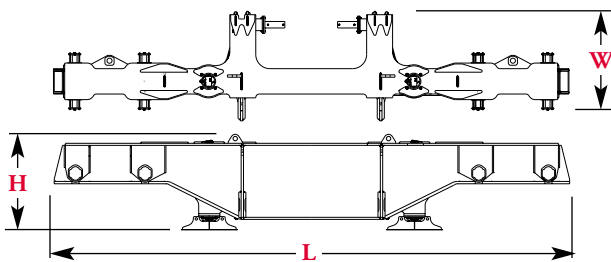

Crawler Beam x 2

Length	11,12 m	36' 6"
Width	2,35 m	7' 9"
Height	2,04 m	6' 9"
Weight	23 736 kg	52,330 lb

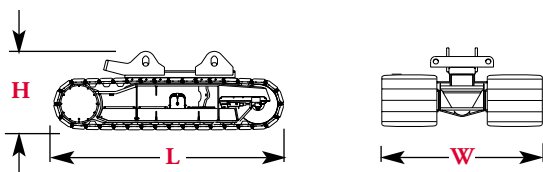

Crawlers x 4

Length	4,97 m	16' 4"
Width	3,50 m	11' 6"
Height	1,71 m	5' 8"
Weight	32 622 kg	71,920 lb

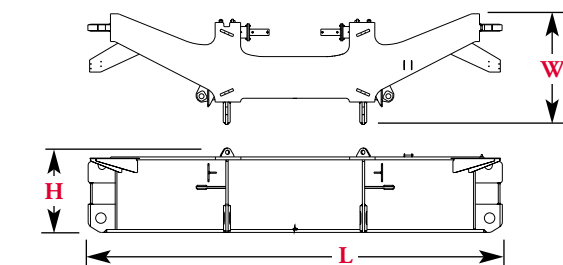

Wide-stance Carbody Beam & Struts x 2

Length	9,11 m	29' 11"
Width	2,44 m	8' 0"
Height	1,86 m	6' 1"
Weight	22 897 kg	50,480 lb

■ Option

outline dimensions

10

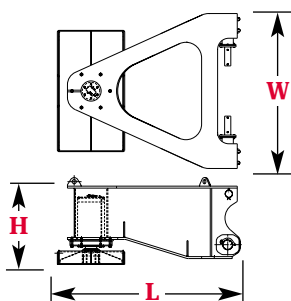

Outriggers & Jacks, Pads x 2		
Length	4,15 m	13' 8"
Width	3,51 m	11' 6"
Height	1,97 m	6' 6"
Weight	12 305 kg	27,130 lb

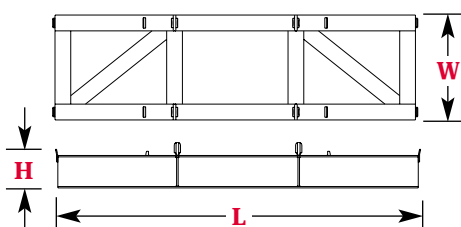

Counterweight Tray x 1		
Length	8,79 m	28' 10"
Width	2,54 m	8' 4"
Height	1,14 m	3' 9"
Weight	11 657 kg	25,700 lb

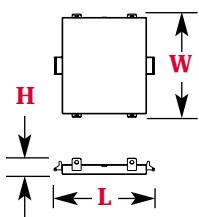

Side Counterweight x 28		
Length	2,55 m	8' 5"
Width	2,61 m	8' 7"
Height	0,41 m	1' 4"
Weight	8 164 kg	18,000 lb

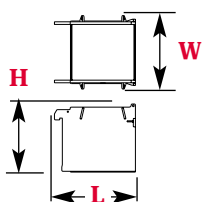

Carbody - Inner Counterweight x 2		
Length	1,95 m	6' 5"
Width	1,77 m	5' 10"
Height	1,65 m	5' 5"
Weight	24 267 kg	53,500 lb

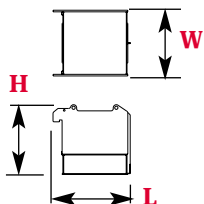

Carbody - Outer Counterweight x 2		
Length	1,84 m	6' 1"
Width	1,56 m	5' 2"
Height	1,66 m	5' 6"
Weight	21 092 kg	46,500 lb

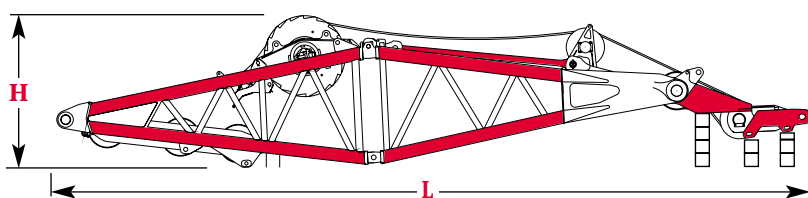

No. 81 Mast Top, Butt, Boom Hoist Drum, Wire Rope Guides, Supports & Straps		
No. 80 Boom Equalizer x 1		
Length	15,01 m	49' 3"
Width	2,41 m	7' 11"
Height	3,06 m	10' 1"
Weight	36 786 kg	81,100 lb

Note: Includes standard amount of wire rope.

outline dimensions

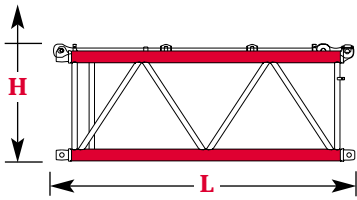

No. 81 6,1 m (20') Mast Insert & Straps x 1

Length	6,35 m	20' 10"
Width	3,38 m	11' 1"
Height	2,50 m	8' 3"
Weight	3 771 kg	8,315 lb

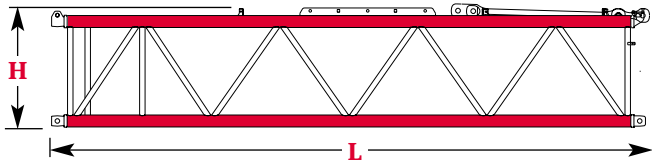

No. 81 12,2 m (40') Mast Insert, Mast Equalizer & Straps x 1

Length	12,45 m	40' 10"
Width	3,38 m	11' 1"
Height	2,50 m	8' 3"
Weight	7 565 kg	16,680 lb

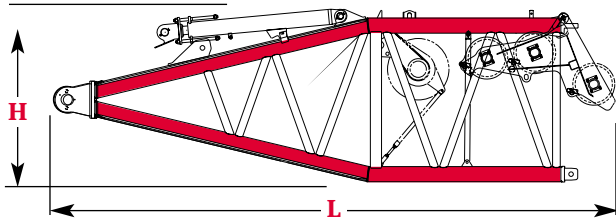

No. 80 Boom Butt, 9,1 m (30') Boom Stop, Wire Rope Guides x 1

Length	10,19 m	33' 5"
Width	3,96 m	13' 0"
Height	3,14 m	10' 4"
Weight	15 778 kg	34,785 lb

Note: Optional auxiliary drum shown.

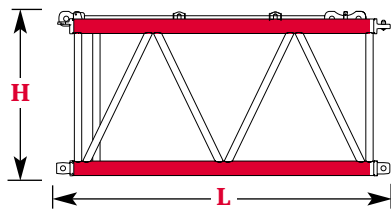

No. 80 6,1 m (20') Boom Insert & Straps x 1, 2

Length	6,34 m	20' 10"
Width	3,96 m	13' 0"
Height	3,14 m	10' 4"
Weight	7 474 kg	16,480 lb

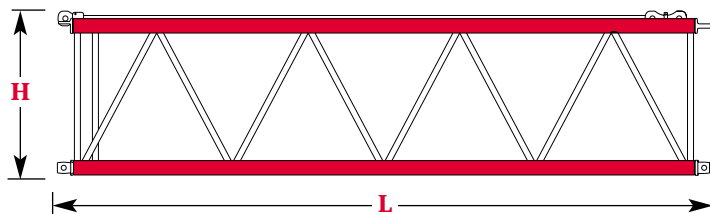

No. 80 12,2 m (40') Boom Insert & Straps x 1, 2 3, 4, 5, 6

Length	12,45 m	40' 10"
Width	3,96 m	13' 0"
Height	3,14 m	10' 4"
Weight	11 341 kg	25,005 lb

Note: For 12,2 m (40') insert with equalizer rail, add 719 kg (1,585 lb) and 178 mm (0' 7") in height.

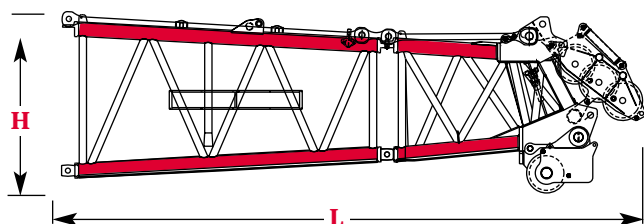

No. 80 Tapered Insert 6,1 m (20'), Boom Top 3,0 m (10'), Wire Rope Guide & Straps x 1

Length	11,18 m	36' 8"
Width	3,96 m	13' 0"
Height	3,14 m	10' 4"
Weight	25 945 kg	57,200 lb

Option

11

outline dimensions

12

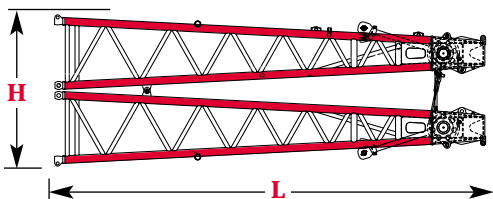
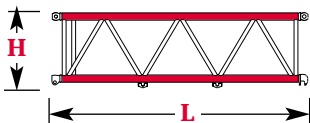
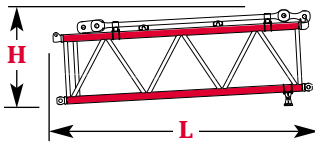
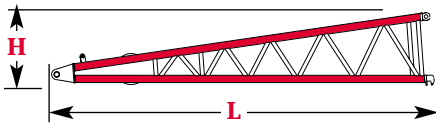
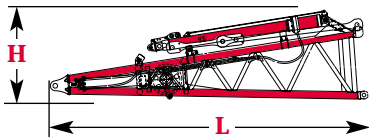
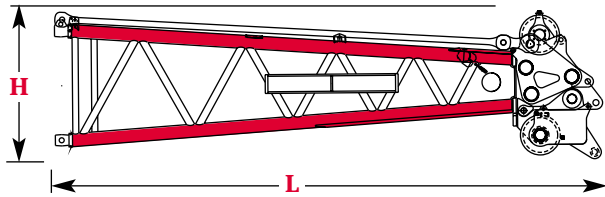
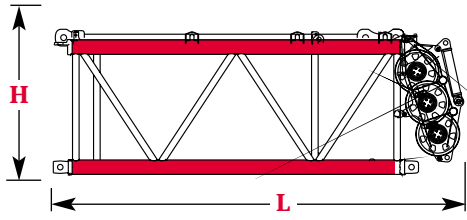

No. 81 Transition Insert 6,1 m (20') Wire Rope Guide & Straps x 1

Length	7,11 m	23' 4"
Width	3,96 m	13' 0"
Height	3,14 m	10' 4"
Weight	6 576 kg	14,501 lb

Note: Shown with wire rope guides from No. 80 boom top in stowed position.

No. 81 Boom Top 9,1 m (30') Wire Rope Guide & Straps x 1

Length	10,46 m	34' 4"
Width	3,38 m	11' 1"
Height	2,50 m	8' 3"
Weight	5 112 kg	33,320 lb

No. 81 Luffing Jib - Main Strut, Butt, Wire Rope Guides, Stops & Straps x 1

Length	7,75 m	25' 5"
Width	3,42 m	11' 3"
Height	2,30 m	7' 7"
Weight	7 263 kg	16,013 lb

No. 81 Luffing Jib - Jib Strut, Butt & Wire Rope Guides x 1

Length	9,35 m	30' 9"
Width	3,17 m	10' 5"
Height	1,77 m	5' 10"
Weight	4 707 kg	10,376 lb

No. 81 Luffing Jib - 6,1 m (20') Main Strut Insert & Straps x 1

Length	6,28 m	20' 8"
Width	2,44 m	8' 0"
Height	3,14 m	10' 4"
Weight	3 208 kg	7,704 lb

No. 81 Luffing Jib - 6,1 m (20') Jib Strut Insert x 1

Length	6,28 m	20' 8"
Width	2,44 m	8' 0"
Height	1,85 m	6' 1"
Weight	2 184 kg	4,814 lb

No. 81 Luffing Jib - Main Strut Top & Jib Strut Top x 1

Length	10,24 m	33' 7"
Width	2,44 m	8' 0"
Height	3,63 m	11' 11"
Weight	9 931 kg	21,894 lb

Note: Shown in standard shipping configuration

Option

outline dimensions

13

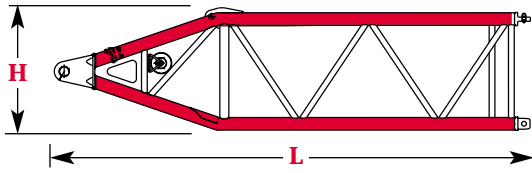

No. 81 Luffing Jib Butt 9,1 m (30') & Wire Rope Guide x 1

Length	9,40 m	30'10"
Width	1,78 m	5' 11"
Height	0,82 m	2' 8"
Weight	7 699 kg	16,975 lb

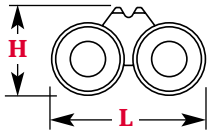

No. 81 Luffing Jib Dolly x 1

Length	2,88 m	9' 6"
Width	2,37 m	7' 10"
Height	1,60 m	5' 3"
Weight	3 057 kg	6,740 lb

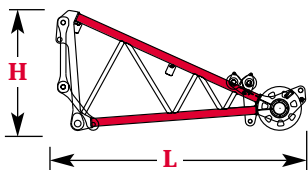

Upper Boom Point 4,6 m (15') Wire Rope Guide & Straps x 1

Length	4,26 m	14' 0"
Width	1,17 m	3' 10"
Height	2,21 m	7' 3"
Weight	1 360 kg	3,000 lb

Note: Can be on No. 80 or No. 81 boom.

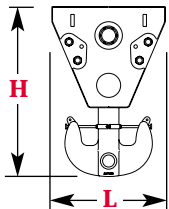

544-mton (600-ton) Block with 544-mton (600-ton) Hook x1

Length	1,68 m	5' 6"
Width	1,26 m	4' 2"
Height	2,51 m	8' 3"
Weight	16 828 kg	37,100 lb

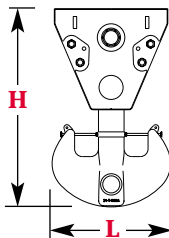

544-mton (600-ton) Block with 907-mton (1,000-ton) Hook x1

Length	1,76 m	5' 9"
Width	1,26 m	4' 2"
Height	3,04 m	10' 0"
Weight	21 318 kg	47,000 lb

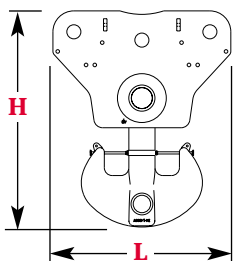

907-mton (1,000-ton) Block with 907-mton (1,000-ton) Hook x1

Length	2,59 m	8' 6"
Width	1,15 m	3' 10"
Height	3,13 m	10' 3"
Weight	31 751 kg	70,000 lb

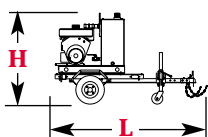

Portable Hydraulic Power Unit x1

Length	1,95 m	6' 1"
Width	1,4 m	4' 5"
Height	1,3 m	4' 2"
Weight	839 kg	1,850 lb

Option

transport data

14

Trailer Load Out Summary

Item	Model 21000 Narrow Configuration		No. 80 Boom 109,7 m (360') and No. 81 Mast 30,5 m (100')																	
	Weight each Item kg (lb)	Quantity on Trailer Load #																		
		1	2-3	4-7	8	9	10-11	12-13	14	15	16	17	18-26	27	28-30	31	32-35	36	37	38
Carbody, Slewing Adapter Frame, Swingers	42 456 (93,600)	1																		
Crawler Beam	23 736 (52,330)		1																	
Crawler Assembly	32 622 (71,920)			1																
Rotating Bed Front & Cab	42 984 (94,765)				1															
Rotating Bed Rear	36 139 (79,675)					1														
Carbody Inner Counterweight	24 267 (53,500)						1													
Carbody Outer Counterweight	21 092 (46,500)							1												
Counterweight Tray & Catwalk	11 657 (25,700)								1											
Side Counterweight Box	8 164 (18,000)									1	1	2		1	1	1				
No. 81 Mast Top & Butt, Equalizer, Guides	36 786 (81,100)									1										
6,1 m (20') No. 81 Mast Insert & Straps	3 771 (8,315)										1									
12,2 m (40') No. 81 Mast Insert & Straps	7 565 (16,680)											1								
9,1 m (30') No. 80 Boom Butt, Stop & Guides	15 778 (34,785)												1							
6,1 m (20') No. 80 Boom Insert & Straps	7 474 (16,480)														1					
12,2 m (40') No. 80 Boom Insert & Straps	11 341 (25,005)													1		1				
6,1 m (20') No. 80 Transition Insert & 3,0 m (10') Top	25 945 (57,200)																1			
544-mton (600-ton) Hook Block	16 828 (37,100)																		1	
Miscellaneous*									1		1	1	1		1				1	1
Approximate Total Shipping Weight Each Trailer Load kg (lb)	42 456 (93,600)	23 736 (52,330)	36 622 (71,920)	42 984 (94,765)	36 139 (79,765)	24 267 (53,500)	21 092 (46,500)	11 657 (25,700)	36 786 (81,100)	11 935 (26,315)	15 729 (34,680)	16 328 (36,000)	15 778 (34,785)	19 505 (43,005)	15 638 (34,480)	19 505 (43,005)	25 945 (57,200)	16 828 (37,100)	18 144 (40,000)	

Trailer configurations - double drop (#1); single drop (#s 8-9, 15, 17, 27-36); flat (#s 2-7, 14, 16, 18-26, 37-38).

*Miscellaneous weights vary and are not listed in trailer load totals

assembly

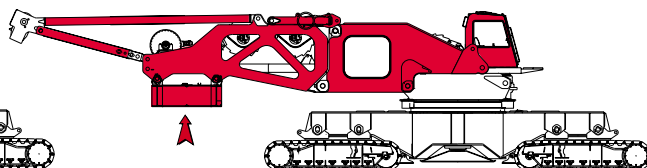
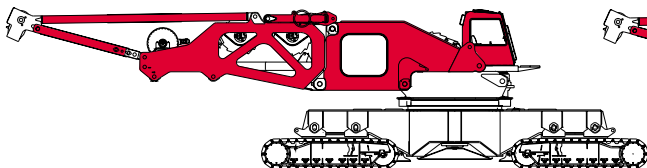
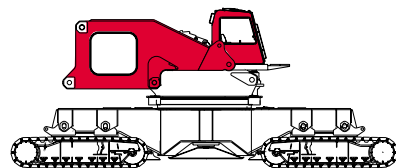
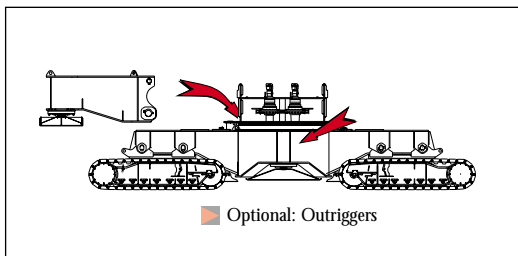
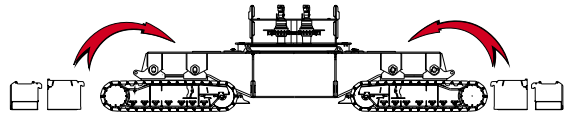
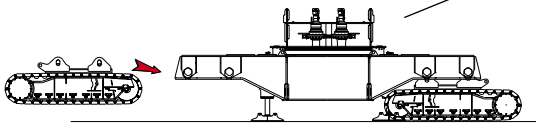
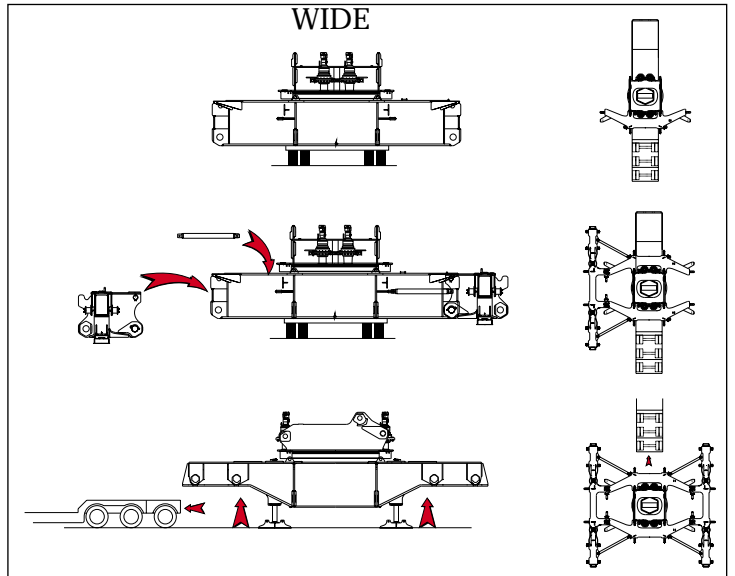
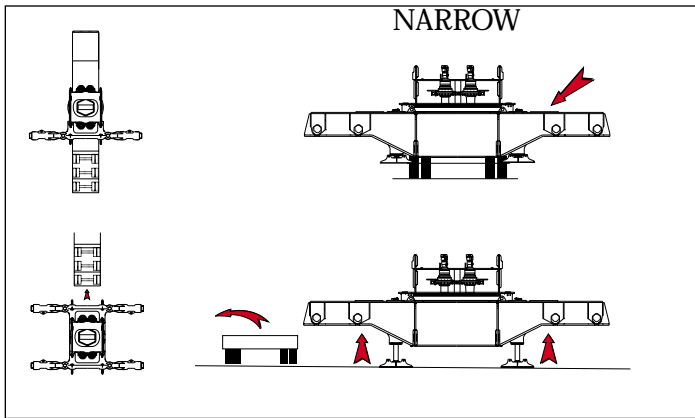
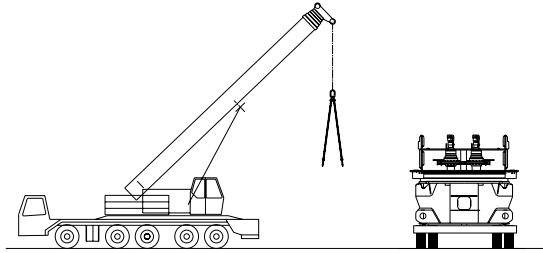

assembly

16

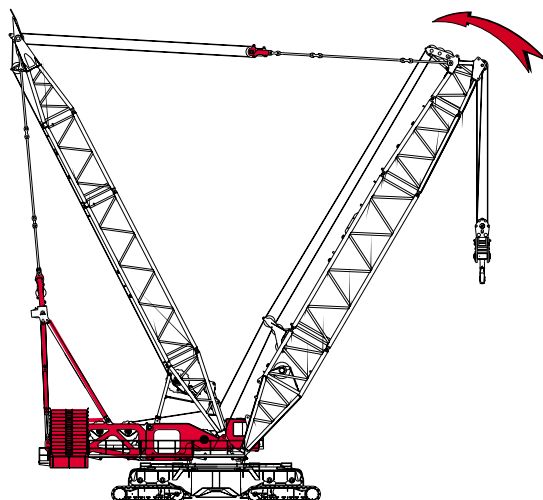
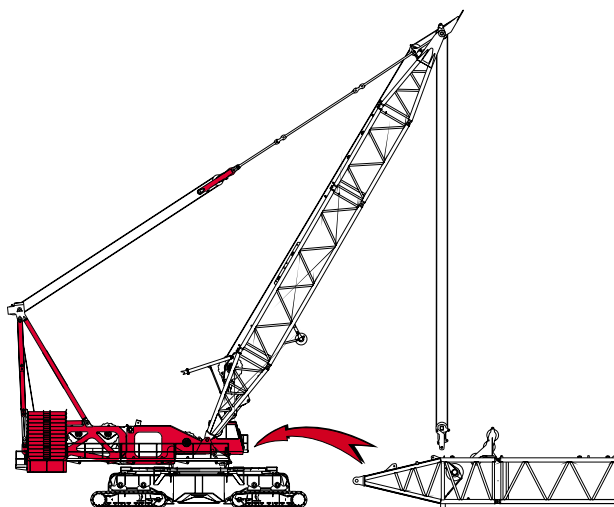
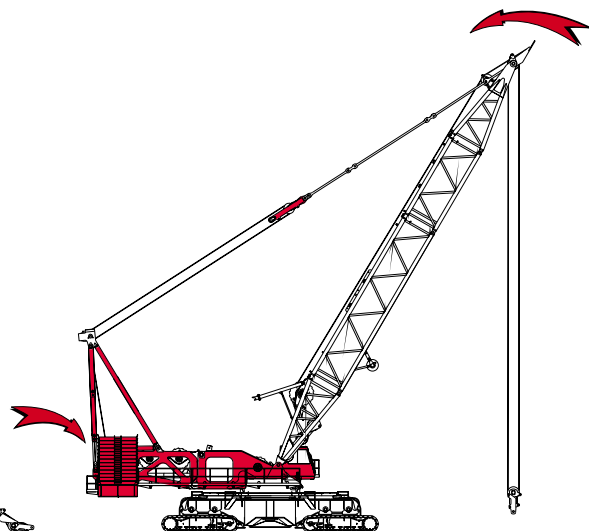
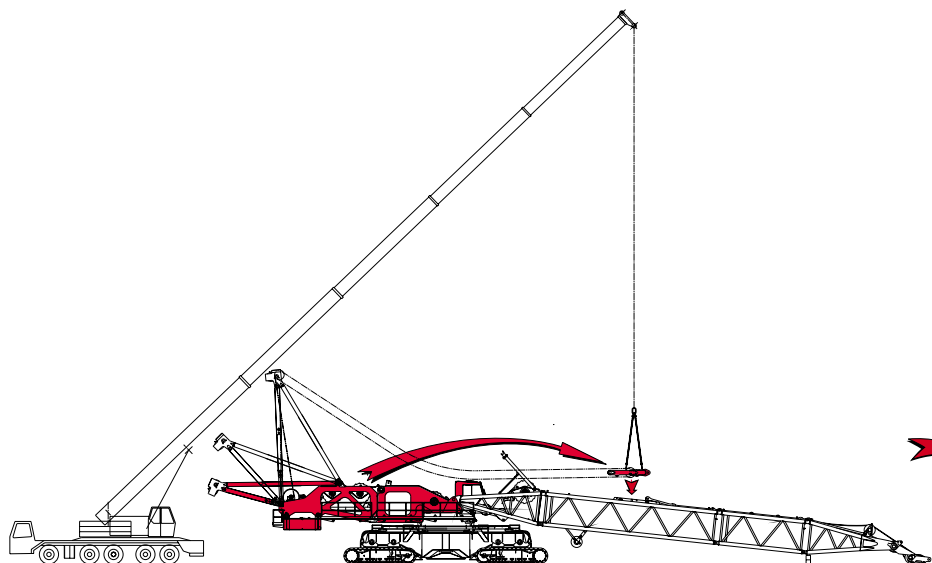
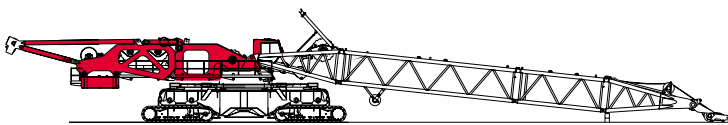
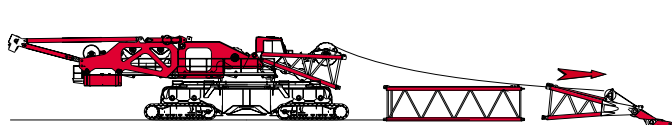
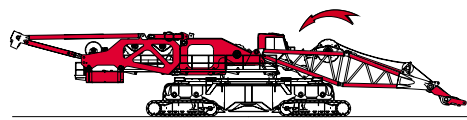
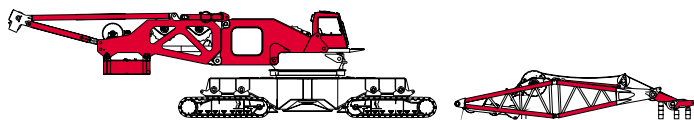

performance data

17

Wire Rope Lengths Boom No. 80 Single Drum - Single Boom Point

Boom Length	Whip Line Drum 2 or 3				Hoist line Drum 1		Maximum Required Parts of Line
	(1 Part of Line)		(2 Parts of Line)				
	m	(ft)	m	(ft)	m	(ft)	
30,5 (100)	88	(290)	130	(425)	975	(3,200)	28
36,6 (120)	101	(330)	145	(475)	1 158	(3,800)	28
42,7 (140)	113	(370)	160	(525)	1 341	(4,400)	28
48,8 (160)	125	(410)	183	(600)	1 494	(4,900)	28
54,9 (180)	137	(450)	198	(650)	1 554	(5,100)	26
61,0 (200)	149	(490)	221	(725)	1 585	(5,200)	24
67,1 (220)	162	(530)	236	(775)	1 615	(5,300)	22
73,2 (240)	174	(570)	251	(825)	1 615	(5,300)	20
79,2 (260)	186	(610)	274	(900)	1 615	(5,300)	18
85,3 (280)	198	(650)	290	(950)	1 676	(5,500)	18
91,4 (300)	210	(690)	312	(1,025)	1 676	(5,500)	16
97,5 (320)	223	(730)	328	(1,075)	1 676	(5,500)	16
103,6 (340)	235	(770)	343	(1,125)	1 676	(5,500)	14
109,7 (360)	247	(810)	366	(1,200)	1 676	(5,500)	14

Note: Line lengths are based on single part lead line. Hoist line and whip line lengths given in table will allow hook to touch ground. When block travel below ground is required, add additional rope equal to parts of line times added travel distance. Hoisting distance or line pull may be limited when block travel below ground is required.

Wire Rope Lengths Boom No. 80 Tandem Drums - Tandem Boom Point

Boom Length	Whip Line Drum 3				Hoist Line Drum 1		Hoist Line Drum 2		Total Parts of Line
	(1 Part of Line)		(2 Parts of Line)						
	m	(ft)	m	(ft)	m	(ft)	m	(ft)	
30,5 (100)	88	(290)	130	(425)	640	(2,100)	640	(2,100)	36
36,6 (120)	101	(330)	145	(475)	701	(2,300)	701	(2,300)	32
42,7 (140)	113	(370)	160	(525)	792	(2,600)	792	(2,600)	32
48,8 (160)	125	(410)	183	(600)	792	(2,600)	792	(2,600)	28

Note: Hoist line lengths are based on tandem drums both reeved to main load block. Each drum is dead ended in main load block reeving. Total parts of line requires using both drums 1 and 2.

Hoist line and whip line lengths given in table will allow hook to touch ground. When block travel below ground is required, add additional rope equal to parts of line times added travel distance. Hoisting distance or line pull may be limited when block travel below ground is required.

performance data

18

Wire Rope Lengths Boom No. 80-81 Single Drum

Boom Length m (ft)	Whip Line Drum 2 or 3		Hoist line Drum 1		Maximum Required Parts of Line
	(1 Part of Line) m (ft)	(2 Parts of Line) m (ft)	m (ft)	m (ft)	
54,9 (180)	137 (450)	198 (650)	1 676 (5,500)	1 676 (5,500)	28
61,0 (200)	149 (490)	221 (725)	1 676 (5,500)	1 676 (5,500)	24
67,1 (220)	162 (530)	236 (775)	1 676 (5,500)	1 676 (5,500)	22
73,2 (240)	174 (570)	251 (825)	1 676 (5,500)	1 676 (5,500)	20
79,2 (260)	186 (610)	274 (900)	1 676 (5,500)	1 676 (5,500)	18
85,3 (280)	198 (650)	290 (950)	1 676 (5,500)	1 676 (5,500)	18
91,4 (300)	210 (690)	312 (1,025)	1 676 (5,500)	1 676 (5,500)	16
97,5 (320)	223 (730)	328 (1,075)	1 676 (5,500)	1 676 (5,500)	16+
103,6 (340)	235 (770)	343 (1,125)	1 676 (5,500)	1 676 (5,500)	14
109,7 (360)	247 (810)	366 (1,200)	1 676 (5,500)	1 676 (5,500)	14
115,8 (380)	259 (770)	381 (1,125)	1 676 (5,500)	1 676 (5,500)	12
121,9 (400)	271 (810)	404 (1,200)	1 676 (5,500)	1 676 (5,500)	12

Note: Line lengths are based on single part lead line. Hoist line and whip line lengths given in table will allow hook to touch ground. When block travel below ground is required, add additional rope equal to parts of line times added travel distance. Hoisting distance or line pull may be limited when block travel below ground is required.

Wire Rope Specifications Boom No. 80 - or - Boom No. 80-81 - or - Luffing Jib No. 81 on Boom No. 80

	5:1 Safety Factor Rotation Resistant Regular Right Hand Lay 2 160 N/mm ²
Function	Hoist or Whip Line
Part Number	No. 719413
Size Wire Rope	32 mm
Minimum Breaking Strength	110 680 kg (244,000 lb)
Maximum Load Per Line	22 140 kg (48,800 lb)
Approximate Weight	4,81 kg/m (3.23 lb/ft)

Drum Capacities - Wire Rope

	Maximum Length	Number of Layers
Drum 1, 2, 3, 6 (Hoist or Whip) 32 mm Wire Rope*	1 475 m (4,840 ft)	10

*7 m (22') is deducted from maximum spooling capacities for 3 dead wraps per drum.

Working Weight

Configuration	kg (lb)
30,5 m (100') No. 80 Boom	814 683 (1,796,070)
121,9 m (400') No. 80-81 Long-Reach Boom	866 194 (1,909,630)

Typical working weight includes: hydraulic reservoirs full, fuel half-full, drums loaded with standard lengths of wire rope, upper boom point, 544 mt (600 t) hook block, and 23.0 mt (25 t) weight ball.

Drum Identification

Drum Number	Function
1	Front Load Drum - Standard
2	Rear Load Drum - Standard
3	Auxiliary Load Drum or Luffing Hoist - Optional
4	Boom Hoist - Standard
5	Mast Hoist - Standard
6	Auxiliary Load Drum - Optional

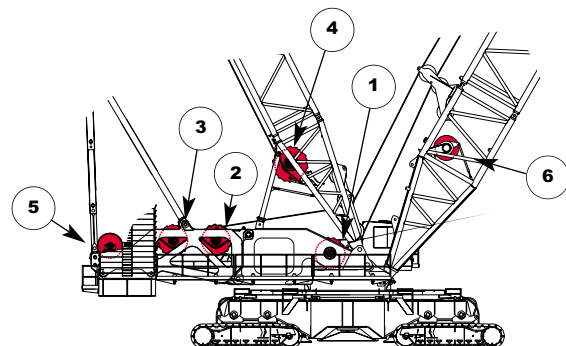

performance data

19

Drums 1 & 2 - 217 kN (48,800 lb)

Layer	Single Line Pull/Single Line Speed*									
	m/min (ft/min)									
	1	2	3	4	5	6	7	8	9	10
Line Pull kN (lb)										
0 (0)	88 (288)	96 (315)	104 (342)	112 (368)	120 (395)	129 (422)	137 (448)	145 (475)	153 (502)	161 (528)
22,2 (5,000)	86 (283)	94 (308)	102 (334)	109 (359)	117 (384)	125 (409)	132 (434)	140 (459)	148 (484)	155 (509)
44,5 (10,000)	84 (277)	92 (301)	99 (325)	106 (349)	114 (373)	121 (397)	128 (420)	135 (443)	142 (467)	149 (489)
66,7 (20,000)	81 (265)	87 (287)	94 (309)	101 (330)	107 (351)	113 (372)	119 (392)	126 (412)	131 (431)	137 (450)
133,4 (30,000)	77 (254)	84 (274)	89 (293)	95 (312)	97 (317)	98 (323)	100 (328)	101 (333)	103 (338)	105 (343)
178,0 (40,000)	72 (237)	74 (242)	75 (247)	77 (252)	78 (257)	80 (262)	81 (267)	83 (272)	85 (278)	86 (283)
000,0 (48,800)	62 (204)	64 (209)	65 (214)	67 (219)	68 (224)	70 (230)	72 (235)	73 (240)	75 (245)	76 (250)

NOTE: Line pull is infinitely variable.

*Based on lagging diameter of 660 mm (26").

Drum 3 - 217 kN (48,800 lb)

Layer	Single Line Pull/Single Line Speed*									
	m/min (ft/min)									
	1	2	3	4	5	6	7	8	9	10
Line Pull kN (lb)										
0 (0)	88 (288)	96 (315)	104 (342)	112 (368)	120 (395)	129 (422)	137 (448)	145 (475)	153 (502)	161 (528)
22,2 (5,000)	86 (281)	93 (306)	101 (331)	109 (356)	116 (381)	124 (406)	131 (430)	138 (454)	146 (479)	153 (503)
44,5 (10,000)	83 (273)	91 (297)	98 (320)	105 (344)	112 (367)	119 (389)	126 (412)	132 (434)	139 (456)	146 (478)
66,7 (20,000)	79 (258)	85 (279)	91 (299)	97 (319)	103 (338)	109 (357)	111 (363)	112 (366)	113 (370)	114 (373)
133,4 (30,000)	73 (241)	74 (244)	75 (247)	77 (251)	77 (254)	78 (257)	79 (260)	80 (263)	81 (267)	82 (270)
178,0 (40,000)	58 (189)	59 (193)	60 (196)	61 (199)	62 (202)	62 (205)	64 (209)	65 (212)	66 (215)	66 (218)
000,0 (48,800)	49 (161)	50 (165)	51 (168)	52 (171)	53 (174)	54 (178)	55 (181)	56 (184)	57 (187)	58 (190)

NOTE: Line pull is infinitely variable.

*Based on drum diameter of 660 mm (26").

Drums & Laggings - Liftcrane

Application	Drums						
	Drum Location	Drum Part Number	Drum Type	Drum Diameter	Drum Width	Wire Rope Size	
Basic Liftcrane	Hoist	Drum 1	192244	Grooved	660 mm (26")	1 664 mm (65-1/2")	32 mm -
	Whip	Drum 2	192244	Grooved	660 mm (26")	1 664 mm (65-1/2")	32 mm -
	Whip (Optional)	Drum 3	192244	Grooved	660 mm (26")	1 664 mm (65-1/2")	32 mm -

model 21000



boom combinations

20

No. 80 Main Boom Combinations

Boom Length m (ft)	Boom Inserts		
	6,1 m (20 ft)	12,2 m* (40 ft)*	12,2 m (40 ft)
30,5 (100)	-	-	-
36,6 (120)	1	-	-
42,7 (140)	-	1	-
48,8 (160)	1	1	-
54,9 (180)	-	2	-
61,0 (200)	1	2	-
67,1 (220)	-	2	1
73,2 (240)	1	2	1
79,2 (260)	-	2	2
85,3 (280)	1	2	2
91,4 (300)	-	2	3
97,5 (320)	1	2	3
103,6 (340)	-	2	4
109,7 (360)	1	2	4

*Inserts do not require boom support strap.

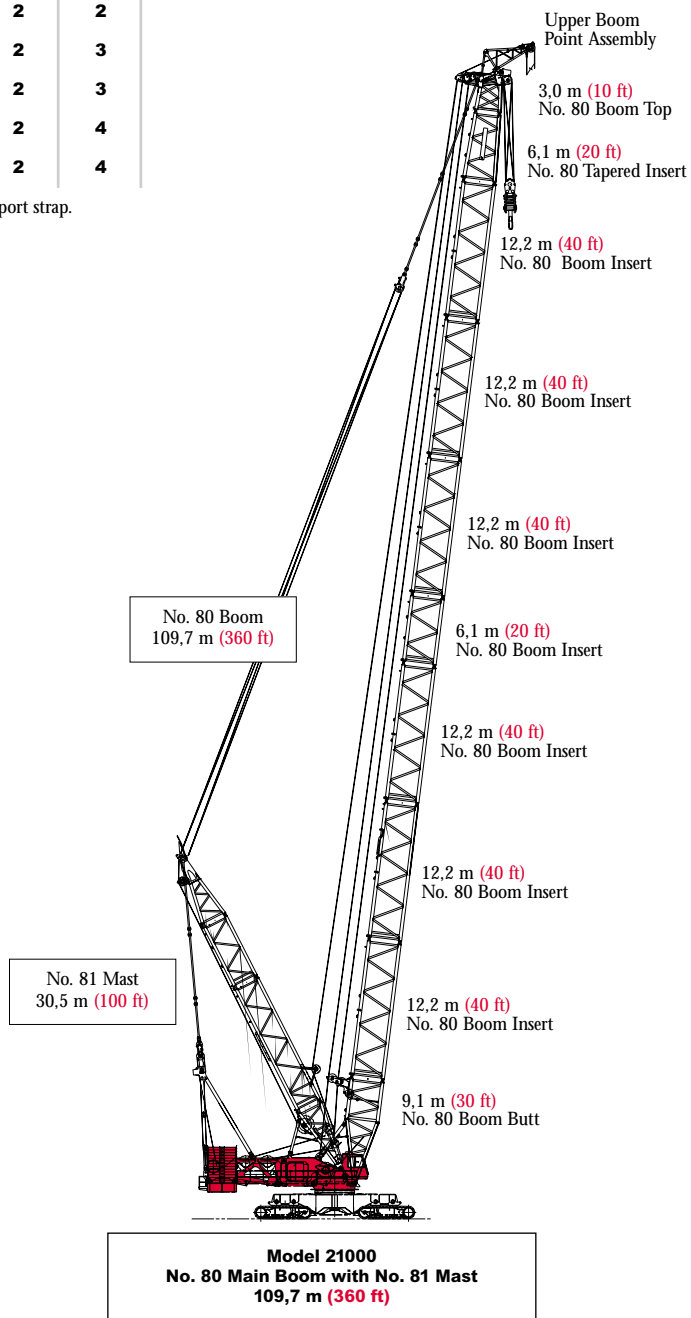

boom combinations

No. 80-81 Main Boom Combinations

Boom Length m (ft)	No. 80 Inserts			No. 81 Inserts	
	6,1 m (20 ft)	12,2 m* (40 ft)*	12,2 m (40 ft)	6,1 m (20 ft)	12,2 m (40 ft)
54,9 (180)	-	-	-	-	-
61,0 (200)	1	-	-	-	-
67,1 (220)	-	1	-	-	-
73,2 (240)	1	1	-	-	-
79,2 (260)	-	1	1	-	-
85,3 (280)	1	1	1	-	-
91,4 (300)	1	1	1	1	-
97,5 (320)	1	1	1	-	1
103,6 (340)	1	1	1	1	1
109,7 (360)	1	1	1	-	2
115,8 (380)	1	1	1	1	2
121,9 (400)	1	1	1	-	3

*Inserts do not require boom support strap.

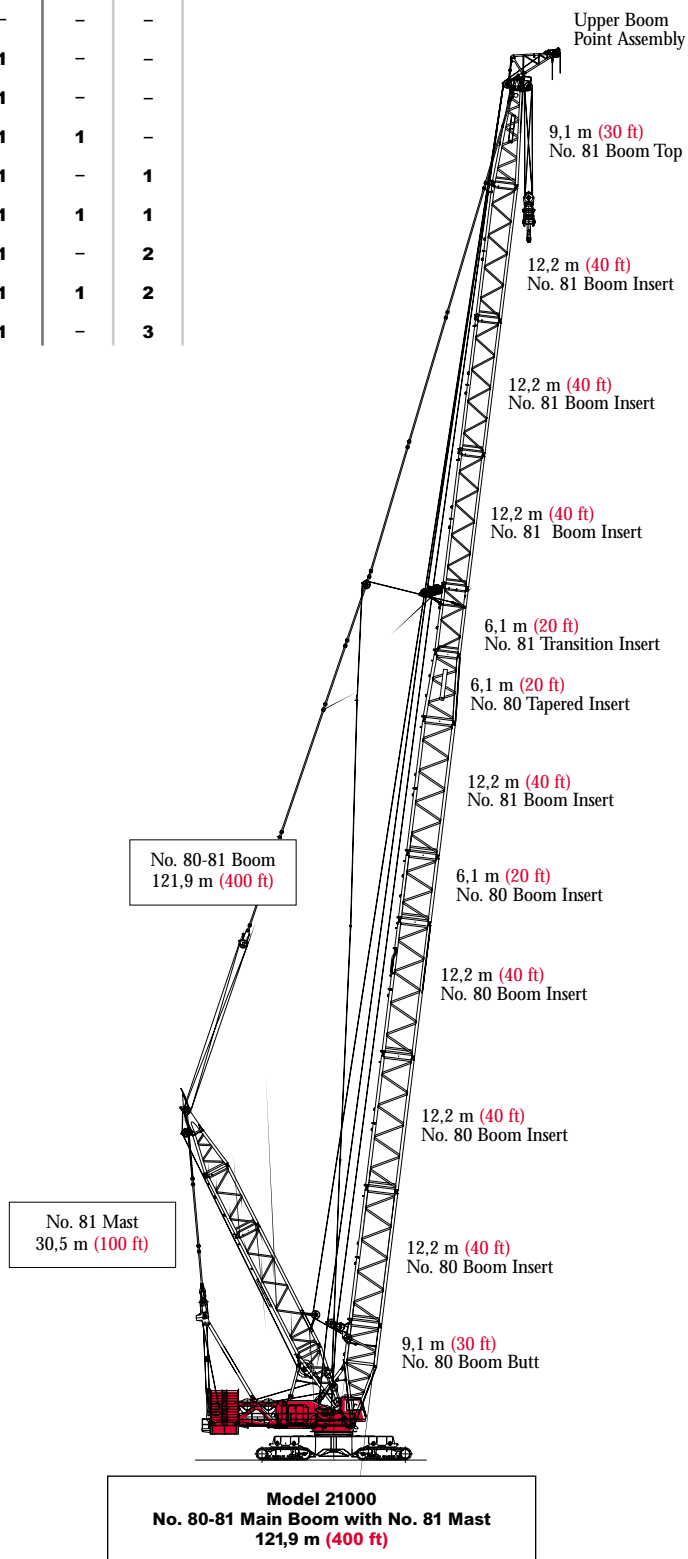

heavy-lift boom range diagram

No. 80 Heavy-Lift Boom

22

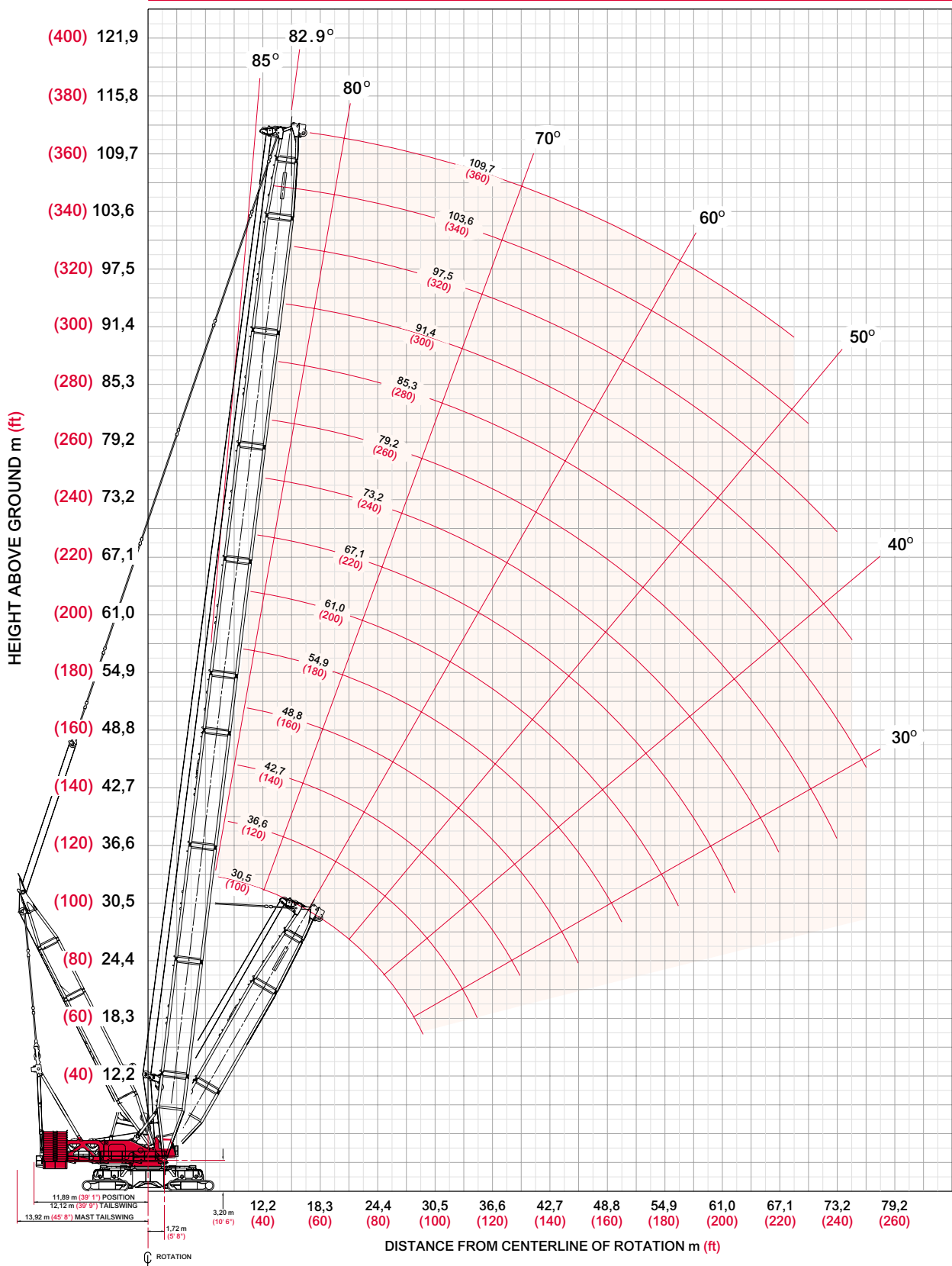

heavy-lift load charts

23

Liftcrane Boom Capacities

Boom No. 80 with 30,5 m (100') Mast

240 720 kg (530,700 lb) Crane Counterweight

90 720 kg (200,000 lb) Carbody Counterweight

360° Rating for wide crawler arrangement or narrow crawler arrangement with outriggers

kg (lb) x 1 000

Boom m (ft)	30,5 (100)	36,6 (120)	42,7 (140)	48,8 (160)	54,9 (180)	61,0 (200)	73,2 (240)	85,3 (280)	91,4 (300)	97,5 (320)	103,6 (340)	109,7 (360)
Radius												
7,0 (23)	756,6 (1668.2)											
8,0 (26)	667,4 (1485.0)	665,0 (1478.8)										
9,0 (30)	595,8 (1293.6)	593,0 (1287.6)	591,8 (1283.8)	- (1277.5)								
10,0 (34)	537,5 (1144.1)	534,8 (1138.3)	533,1 (1134.7)	530,3 (1128.6)	- (1130.8)							
12,0 (40)	448,3 (972.7)	445,7 (967.2)	444,2 (963.7)	441,5 (957.8)	442,5 (960.2)	440,5 (955.7)	- (948.2)					
16,0 (50)	333,6 (774.1)	331,2 (768.8)	329,8 (765.6)	327,2 (759.9)	328,4 (762.5)	326,3 (757.9)	322,9 (750.3)	319,1 (742.1)	317,7 (737.1)	316,1 (733.5)		
18,0 (60)	292,9 (633.8)	290,9 (629.4)	289,5 (626.5)	287,2 (621.5)	288,5 (624.5)	286,5 (620.3)	283,3 (613.5)	279,9 (606.1)	277,8 (601.6)	276,3 (598.4)	274,5 (593.7)	272,8 (589.9)
22,0 (70)	231,6 (529.6)	229,7 (525.3)	228,4 (522.5)	226,3 (517.7)	227,6 (520.7)	225,7 (516.4)	222,5 (509.4)	219,0 (501.8)	216,9 (497.2)	215,4 (493.9)	213,3 (489.2)	211,7 (485.7)
24,0 (80)	208,9 (452.1)	207,0 (447.9)	205,8 (445.2)	203,6 (440.5)	205,0 (443.6)	203,0 (439.2)	199,8 (432.1)	196,4 (424.4)	194,2 (419.6)	192,7 (416.3)	190,5 (411.5)	188,9 (408.0)
26,0 (90)	189,8 (392.0)	187,9 (388.1)	186,7 (385.5)	184,6 (380.8)	186,1 (384.1)	184,0 (379.6)	180,8 (372.4)	177,3 (364.6)	175,1 (359.7)	173,5 (356.4)	171,4 (351.6)	169,8 (348.0)
30,0 (100)		157,5 (340.4)	156,3 (337.9)	154,2 (333.3)	155,7 (336.7)	153,7 (332.1)	150,4 (324.8)	146,8 (317.0)	144,6 (312.1)	143,1 (308.7)	140,9 (303.8)	139,2 (300.2)
34,0 (110)		134,2 (301.4)	133,2 (299.1)	131,1 (294.6)	132,7 (298.0)	130,6 (293.4)	127,3 (286.1)	123,7 (278.2)	121,5 (273.3)	119,9 (269.9)	117,7 (265.0)	116,0 (261.3)
36,0 (120)			123,5 (266.7)	121,5 (262.4)	123,1 (265.9)	121,0 (261.3)	117,7 (253.9)	114,0 (245.9)	111,7 (240.4)	110,0 (236.4)	107,6 (230.5)	105,6 (226.1)
40,0 (130)			- (236.1)	103,7 (232.2)	106,5 (238.2)	104,0 (232.9)	100,3 (224.7)	96,0 (215.3)	93,3 (209.4)	91,5 (205.3)	88,7 (199.2)	86,7 (194.8)
44,0 (150)				88,6 (182.8)	91,4 (189.3)	89,1 (184.0)	85,3 (175.6)	80,9 (166.1)	78,2 (160.1)	76,3 (155.9)	73,6 (149.7)	71,5 (145.2)
48,0 (160)					78,9 (169.4)	76,6 (164.2)	72,8 (155.8)	68,5 (146.3)	65,7 (140.1)	63,8 (136.0)	61,0 (129.8)	58,9 (125.3)
52,0 (170)						66,0 (146.7)	62,3 (138.4)	57,9 (128.8)	55,1 (122.6)	53,3 (118.5)	50,4 (112.2)	48,4 (107.7)
54,0 (180)						61,3 (131.0)	57,6 (122.9)	53,2 (113.3)	50,5 (107.1)	48,6 (102.9)	45,7 (96.7)	43,7 (92.1)
60,0 (200)							45,4 (96.4)	41,1 (86.9)	38,3 (80.7)	36,4 (76.6)	33,5 (70.3)	31,5 (65.7)
64,0 (210)							38,5 (85.0)	34,3 (75.6)	31,4 (69.4)	29,6 (65.3)	26,7 (59.0)	24,6 (54.4)
66,0 (220)							35,4 (74.5)	31,2 (65.3)	28,4 (59.2)	26,5 (55.0)	23,6 (48.7)	21,6 (44.2)
70,0 (230)								25,4 (55.9)	22,7 (49.8)	20,8 (45.7)	17,9 (39.3)	
74,0 (240)								20,3 (47.2)	17,6 (41.1)	- (37.0)		
76,0 (250)								17,9 (39.1)				

Meets ANSI B30.5 Requirements - Capacities do not exceed 75% of static tipping load.
 NOTICE: This capacity chart is for reference only and must not be used for lifting purposes.

long-reach boom range diagram

No. 80-81 Long-Reach Boom

24

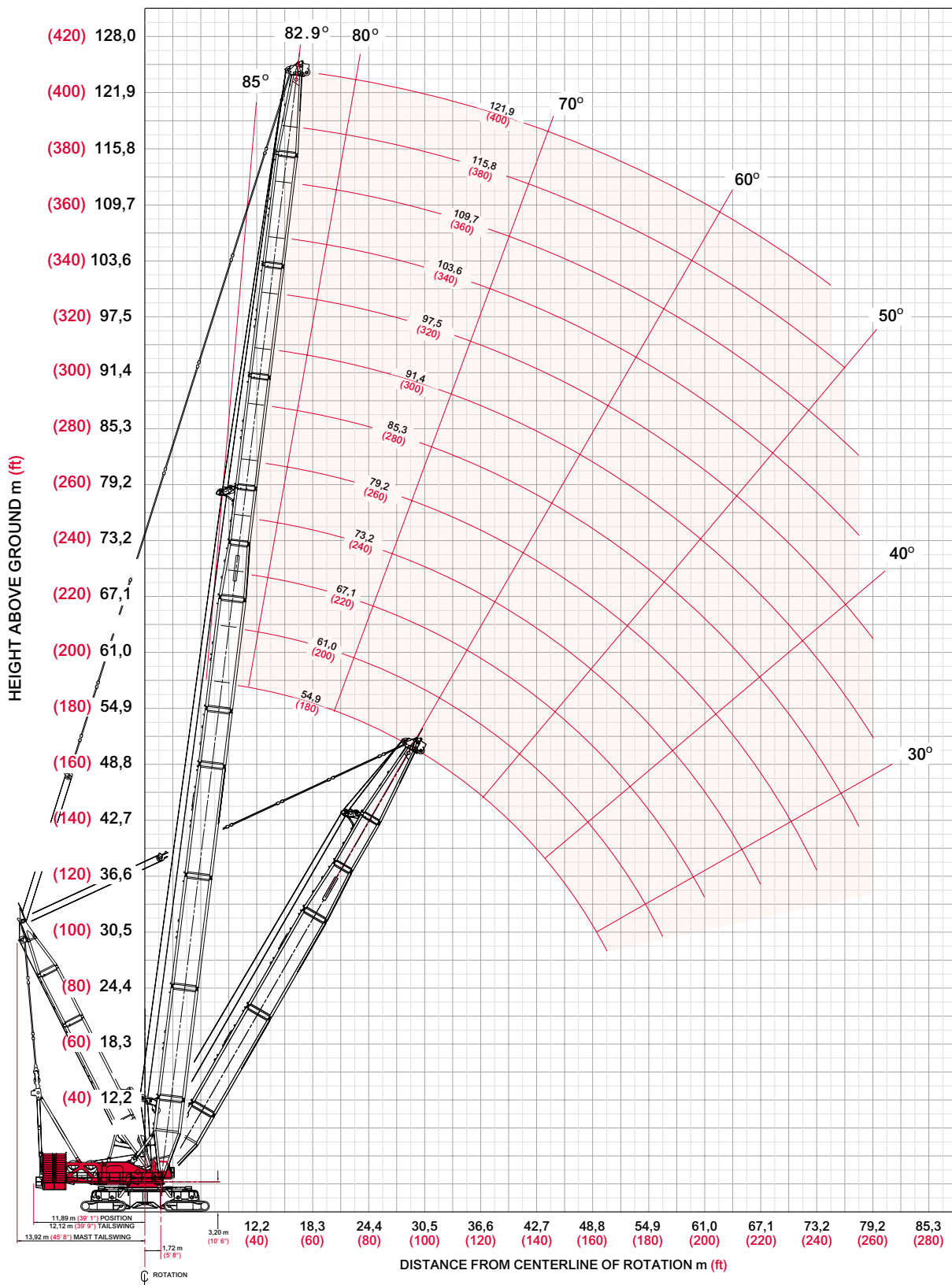

long-reach load charts

25

Liftcrane Boom Capacities

Boom No. 80-81 with 30,5 m (100') Mast

240 720 kg (530,700 lb) Crane Counterweight

90 720 kg (200,000 lb) Carbody Counterweight

360° Rating for wide crawler arrangement or narrow crawler arrangement with outriggers

kg (lb) x 1 000

Boom m (ft)	54,9 (180)	61,0 (200)	67,1 (220)	73,2 (240)	79,2 (260)	85,3 (280)	91,4 (300)	97,5 (320)	103,6 (340)	109,7 (360)	115,8 (380)	121,9 (400)
Radius												
9,8 (32)	544,3 (1200.0)											
12,0 (40)	446,4 (968.8)	443,5 (962.2)	443,0 (957.7)	- (948.4)								
14,0 (45)	381,6 (859.5)	378,8 (853.2)	376,7 (848.7)	374,6 (843.7)	373,6 (840.3)	371,3 (835.2)						
16,0 (50)	332,3 (771.1)	329,5 (764.9)	327,5 (760.5)	325,2 (755.4)	323,7 (752.0)	321,4 (746.9)	321,2 (744.5)	320,7 (743.6)				
18,0 (60)	292,4 (633.2)	289,9 (627.7)	288,0 (623.5)	285,8 (619.0)	284,4 (615.9)	282,3 (611.3)	281,3 (609.3)	281,0 (608.8)	280,1 (606.1)	279,6 (604.9)	- (585.6)	- (504.8)
22,0 (70)	231,6 (529.4)	229,1 (524.0)	227,3 (519.9)	225,1 (515.2)	223,7 (512.1)	221,6 (507.4)	220,6 (505.3)	220,3 (504.7)	219,1 (501.9)	218,6 (500.9)	217,5 (498.4)	210,1 (467.6)
24,0 (80)	209,0 (452.2)	206,5 (446.9)	204,7 (442.9)	202,5 (438.1)	201,1 (435.0)	199,0 (430.2)	198,0 (428.1)	197,7 (427.4)	196,4 (424.5)	195,9 (423.5)	194,8 (420.9)	195,4 (419.5)
26,0 (90)	190,0 (392.6)	187,6 (387.4)	185,7 (383.4)	183,6 (378.6)	182,1 (375.4)	179,9 (370.6)	178,9 (368.4)	178,7 (367.7)	177,4 (364.8)	176,9 (363.7)	175,7 (361.1)	175,0 (359.7)
30,0 (100)	159,6 (345.2)	157,2 (340.0)	155,4 (336.0)	153,3 (331.2)	151,8 (328.0)	149,6 (323.1)	148,6 (321.0)	148,3 (320.3)	147,0 (317.3)	146,5 (316.2)	145,2 (313.5)	144,6 (312.0)
34,0 (110)	136,5 (306.5)	134,2 (301.4)	132,5 (297.5)	130,2 (292.6)	128,8 (289.4)	126,6 (284.5)	125,6 (282.3)	125,2 (281.6)	123,9 (278.6)	123,3 (277.4)	122,1 (274.7)	121,5 (273.3)
36,0 (120)	126,9 (274.3)	124,6 (269.3)	122,9 (265.4)	120,7 (260.5)	119,2 (257.3)	117,0 (252.4)	116,0 (250.2)	115,7 (249.5)	114,3 (246.4)	113,8 (245.3)	112,5 (242.5)	111,8 (241.0)
40,0 (130)	110,6 (247.1)	108,4 (242.2)	106,6 (238.3)	104,3 (233.4)	102,8 (230.0)	100,0 (224.0)	98,9 (221.6)	98,7 (221.2)	97,1 (217.7)	96,6 (216.6)	95,2 (213.5)	94,4 (211.8)
44,0 (150)	96,5 (200.4)	94,0 (195.0)	92,0 (190.6)	89,4 (184.8)	87,7 (181.2)	85,0 (175.0)	83,8 (172.6)	83,6 (172.1)	82,0 (168.4)	81,5 (167.3)	80,0 (164.0)	79,3 (162.3)
48,0 (160)	84,0 (180.4)	81,6 (175.2)	79,6 (170.9)	77,0 (165.1)	75,3 (161.4)	72,5 (155.3)	71,4 (152.8)	71,2 (152.3)	69,5 (148.5)	69,0 (147.4)	67,5 (144.1)	66,7 (142.4)
52,0 (170)		71,0 (157.7)	69,2 (153.6)	66,5 (147.7)	64,9 (144.1)	62,1 (137.9)	60,9 (135.4)	60,6 (134.8)	59,0 (131.1)	58,4 (129.9)	56,9 (126.6)	56,2 (124.9)
54,0 (180)		66,3 (142.1)	64,5 (138.1)	61,9 (132.3)	60,2 (128.6)	57,4 (122.5)	56,2 (119.9)	56,0 (119.4)	54,3 (115.6)	53,7 (114.4)	52,2 (111.1)	51,5 (109.3)
58,0 (190)			56,2 (124.3)	53,5 (118.5)	51,9 (114.8)	49,1 (108.7)	47,9 (106.1)	47,7 (105.6)	46,0 (101.8)	45,4 (100.6)	43,9 (97.2)	43,1 (95.5)
60,0 (200)			52,3 (111.7)	49,8 (106.0)	48,1 (102.4)	45,3 (96.3)	44,2 (93.7)	43,9 (93.2)	42,2 (89.3)	41,6 (88.1)	40,1 (84.8)	39,3 (83.0)
64,0 (210)				42,9 (94.7)	41,3 (91.2)	38,5 (85.0)	37,4 (82.5)	37,2 (82.0)	35,4 (78.1)	34,8 (76.9)	33,3 (73.5)	32,5 (71.8)
66,0 (220)				39,8 (84.3)	38,2 (80.9)	35,4 (74.8)	34,3 (72.3)	34,1 (71.8)	32,3 (67.9)	31,8 (66.7)	30,2 (63.3)	29,4 (61.5)
70,0 (230)					32,5 (71.4)	29,8 (65.4)	28,6 (62.9)	28,4 (62.5)	26,7 (58.6)	26,1 (57.4)	24,6 (54.0)	23,8 (52.2)
74,0 (240)					- (62.7)	24,7 (56.8)	23,6 (54.4)	23,4 (53.9)	21,6 (50.0)	21,1 (48.8)	19,5 (45.4)	18,8 (43.7)
76,0 (250)						22,3 (48.8)	21,2 (46.4)	21,0 (46.0)	19,3 (42.1)	18,7 (40.9)	17,2 (37.5)	
78,0 (260)							19,0 (39.1)	18,8 (38.7)				

Meets ANSI B30.5 Requirements - Capacities do not exceed 75% of static tipping load.
 NOTICE: This capacity chart is for reference only and must not be used for lifting purposes.

outline dimensions

26

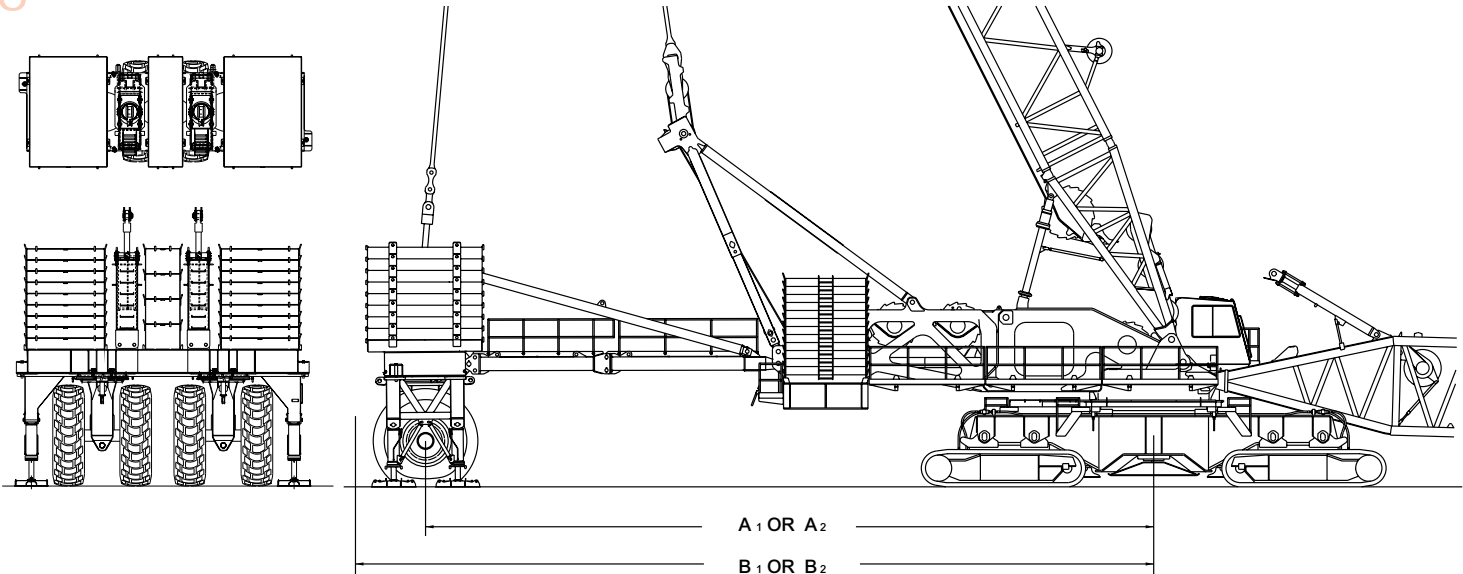

WHEELED COUNTERWEIGHT

A 1 = ONE-PIECE SHEAR FRAME 18,0 m (59' 0")
 A 2 = TWO-PIECE SHEAR FRAME 22,0 m (72' 0")

B 1 = ONE-PIECE SHEAR FRAME 20,4 m (67' 0")
 B 2 = TWO-PIECE SHEAR FRAME 24,4 m (80' 0")

model 21000 with MAX-ER™

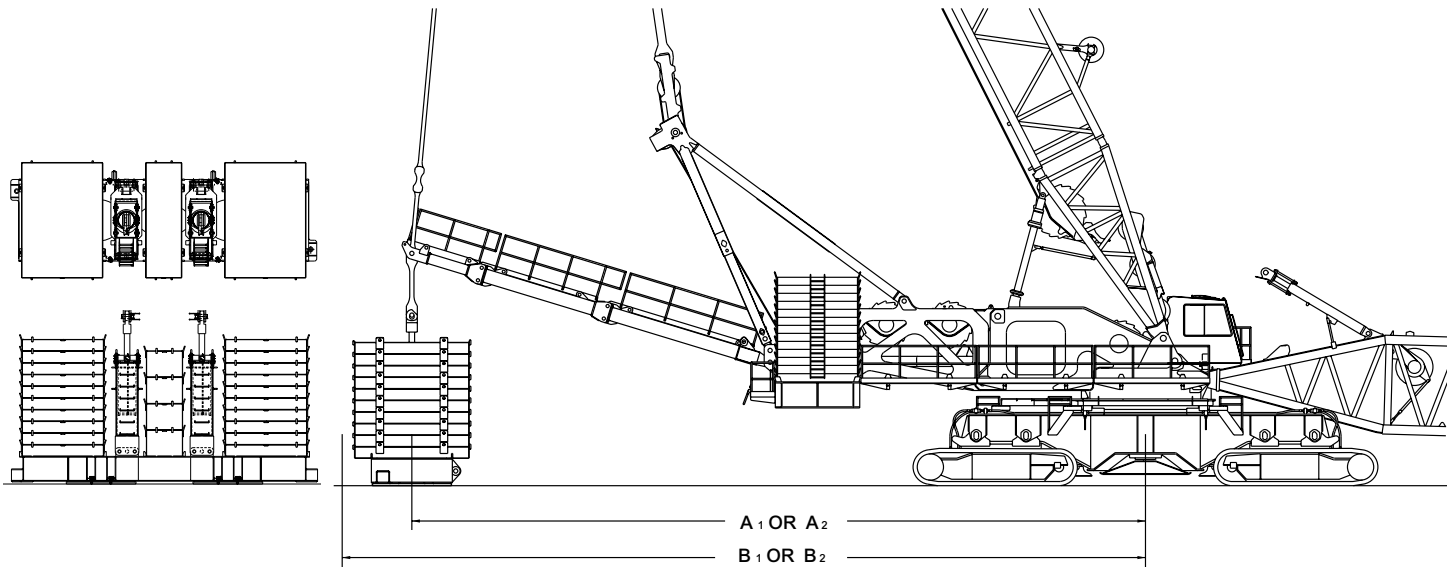

FREE HANGING COUNTERWEIGHT

A 1 = TWO-PIECE SHEAR FRAME 17,9 m (58' 9")
 A 2 = THREE-PIECE SHEAR FRAME 22,1 m (72' 6")

B 1 = TWO-PIECE SHEAR FRAME 20,1 m (66' 0")
 B 2 = THREE-PIECE SHEAR FRAME 24,2 m (79' 6")



outline dimensions

27

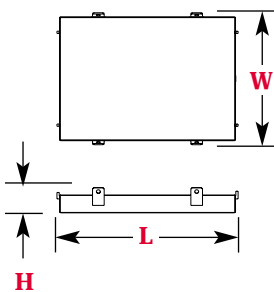
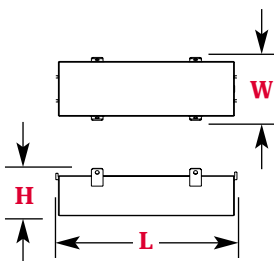
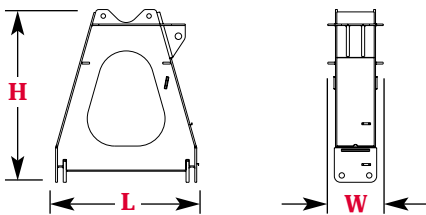
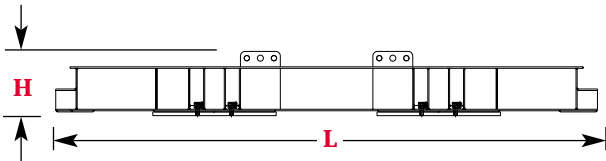
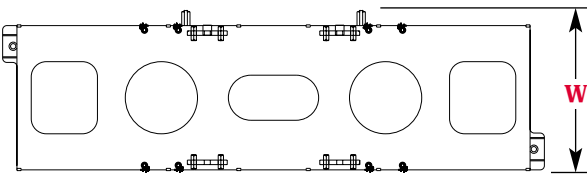
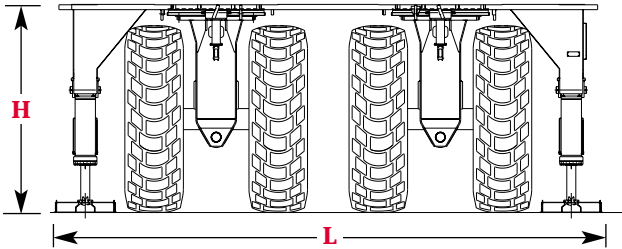
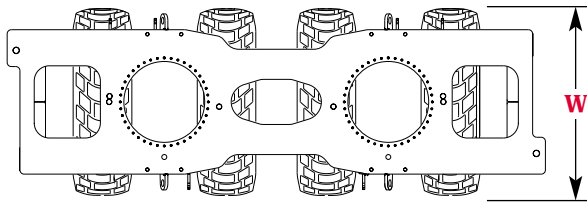

Wheeled Carrier x 1

Length	9,14 m	30' 0"
Width	3,55 m	11' 8"
Height	3,55 m	11' 8"
Weight	63 299 kg	139,555 lb

Counterweight Tray x 1

Length	9,14 m	30' 0"
Width	2,71 m	8' 11"
Height	1,03 m	3' 5"
Weight	15 381 kg	33,910 lb

A-Frame x 2

Length	2,38 m	7' 10"
Width	0,92 m	3' 1"
Height	2,87 m	9' 5"
Weight	3 658 kg	8,065 lb

Center Counterweight Box x 4

Length	3,56 m	11' 8"
Width	1,24 m	4' 10"
Height	0,93 m	3' 1"
Weight	19 958 kg	44,000 lb

Side Counterweight Box x 18, 20

Length	3,56 m	11' 8"
Width	2,59 m	8' 6"
Height	0,50 m	1' 8"
Weight	19 958 kg	44,000 lb

Note: Wheeled carrier requires 18 counterweights, hanging tray requires 20 counterweights.

Option

outline dimensions

28

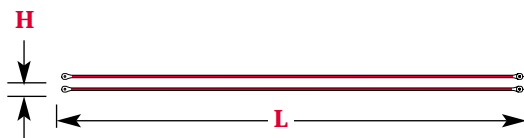
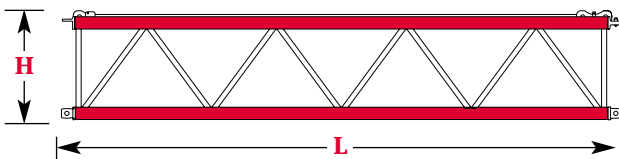
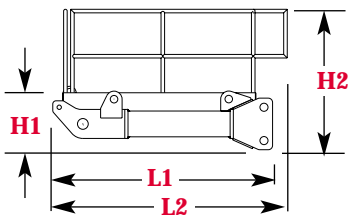
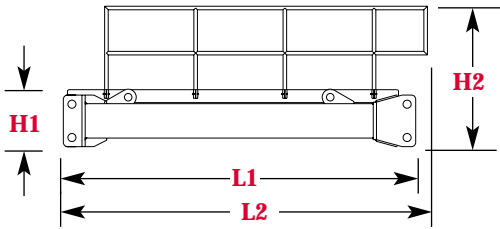
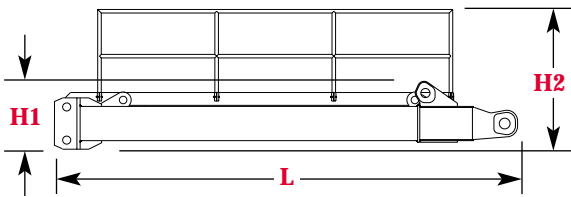
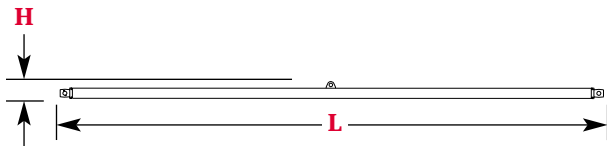
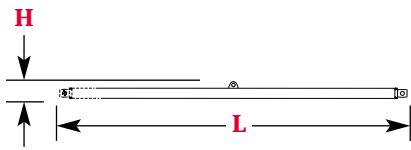

Struts - 5,5 m (18') x 2

Length	5,79 m	19' 0"
Width	0,28 m	0' 11"
Height	0,28 m	0' 11"
Weight	757 kg	1,670 lb

Note: For wheeled counterweight.

Struts - 9,1 m (30') x 2

Length	9,45 m	31' 0"
Width	0,28 m	0' 11"
Height	0,28 m	0' 11"
Weight	1 183 kg	2,610 lb

Note: For wheeled counterweight.

Front Shear Frame & Railings

x 1

Length	5,66 m	18' 7"
Width	3,40 m	11' 2"
Height 1	0,81 m	2' 8"
Weight	4 177 kg	9,210 lb

Note: Shown with railings attached in operating position.

Height 2 1,66 m 5' 6"

Rear Shear Frame & Railings

x 1

Length 1	4,40 m	14' 6"
Width	3,40 m	11' 2"
Height 1	0,67 m	2' 3"
Weight	3 626 kg	7,995 lb

Note: Shown with railings attached in operating position.

Length 2 4,52 m 15' 1"

Height 2 1,66 m 5' 6"

Shear Frame Adapter & Railings

x 1

Length 1	2,61 m	8' 7"
Width	3,40 m	11' 2"
Height 1	0,67 m	2' 3"
Weight	3 225 kg	7,110 lb

Note: Shown with railings attached in operating position.

Length 2 2,77 m 9' 1"

Height 2 1,66 m 5' 6"

No. 81 Mast Insert 12,2 m (40') & Straps

x 1

Length	12,45 m	40' 10"
Width	3,38 m	11' 1"
Height	2,50 m	8' 3"
Weight	8 085 kg	17,825 lb

Straps 8,1 m (26' 8")

x 2

Length	8,41 m	27' 6"
Width	0,08 m	0' 3"
Height	0,28 m	0' 11"
Weight	1 238 kg	2,730 lb

Option

performance data

Wire Rope Lengths Boom No. 80 with MAX-ER™ Tandem Drums - Tandem Boom Point

Boom Length m (ft)	Hoist Line Drum 1 or 2		Maximum Required Parts of Line
	m	(ft)	
42,7 (140)	1 067	(3,500)	44
48,8 (160)	1 189	(3,900)	44
54,9 (180)	1 341	(4,400)	44
61,0 (200)	1 341	(4,400)	40
67,1 (220)	1 463	(4,800)	40
73,2 (240)	1 463	(4,800)	36
79,2 (260)	1 463	(4,800)	32
85,3 (280)	1 463	(4,800)	28
91,4 (300)	1 463	(4,800)	28

Note: Hoist line lengths are based on tandem drums both reeved to main load block. Each drum is dead ended in main load block reeving. Total parts of line requires using both drums 1 and 2.

Hoist line lengths given in table will allow hook to touch ground. When block travel below ground is required, add additional rope equal to parts of line times added travel distance. Hoisting distance or line pull may be limited when block travel below ground is required.

Wire Rope Lengths Boom No. 80 with MAX-ER™ Tandem Drums - Single Boom Point

Boom Length m (ft)	Hoist Line Drum 1 or 2		Maximum Required Parts of Line
	m	(ft)	
97,5 (320)	1 463	(4,800)	24
103,6 (340)	1 463	(4,800)	24
109,7 (360)	1 463	(4,800)	20
115,8 (380)	1 463	(4,800)	16

Note: Hoist line lengths are based on tandem drums, both reeved to main load block. Each drum is dead ended in main load block reeving. Total parts of line requires using both drums 1 and 2.

Hoist line lengths given in table will allow hook to touch ground. When block travel below ground is required, add additional rope equal to parts of line times added travel distance. Hoisting distance or line pull may be limited when block travel below ground is required.

performance data

30

Wire Rope Lengths Luffing Jib No. 81 on Boom No. 80 with MAX-ER™ Single Drum - Single Jib Point

Boom Length m (ft)	Maximum Parts of Line for Full hoisting Range										Hoist Line Drum 1		Whip Line Drum 2			
	Jib Length m (ft)												(1 Part of Line)		(2 Parts of Line)	
	36,6 (120)	42,7 (140)	48,8 (160)	54,9 (180)	61,0 (200)	67,1 (220)	73,2 (240)	79,2 (260)	85,3 (280)	91,4 (300)	m	(ft)	m	(ft)	m	(ft)
54,9 (180)	16	14	14	14	12	12	10	10	8	8	1 676	(5,500)	427	(1,400)	610	(2,000)
61,0 (200)	14	14	14	12	12	10	10	10	8	8	1 676	(5,500)	427	(1,400)	610	(2,000)
67,1 (220)	14	14	12	12	10	10	10	8	8	6	1 676	(5,500)	427	(1,400)	610	(2,000)
73,2 (240)	14	12	12	10	10	10	10	8	8	6	1 676	(5,500)	427	(1,400)	610	(2,000)
79,2 (260)	12	12	10	10	10	10	8	8	6	6	1 676	(5,500)	427	(1,400)	610	(2,000)
85,3 (280)	12	10	10	10	10	8	8	8	6	6	1 676	(5,500)	427	(1,400)	610	(2,000)
91,4 (300)	10	10	10	10	8	8	8	6	6	6	1 676	(5,500)	427	(1,400)	610	(2,000)
97,5 (320)	10	10	10	8	8	8	6	6	6	6	1 676	(5,500)	427	(1,400)	610	(2,000)
103,6 (340)	10	10	8	8	8	8	6	6	6	6	1 676	(5,500)	427	(1,400)	610	(2,000)

Note: Line lengths are based on single part lead line. Hoist line and whip line lengths given in table will allow hook to touch ground. When block travel below ground is required, add additional rope equal to parts of line times added travel distance. Hoisting distance or line pull may be limited when block travel below ground is required.

Wire Rope Lengths Luffing Jib No. 81 on Boom No. 80 with MAX-ER™ Tandem Drums - Single Jib Point

Boom Length m (ft)	Parts of line for Maximum Capacity						Hoist Line Drum 1		Hoist Line Drum 2	
	Jib Length m (ft)									
	36,6 (120)	42,7 (140)	48,8 (160)	54,9 (180)	61,0 (200)	67,1 (220)	m	(ft)	m	(ft)
54,9 (180)	24	20	20	16	16	12	1 250	(4,100)	1 250	(4,100)
61,0 (200)	20	20	16	16	16	12	1 250	(4,100)	1 250	(4,100)
67,1 (220)	20	16	16	16	12		1 250	(4,100)	1 250	(4,100)
73,2 (240)	16	16	16	12	12		1 250	(4,100)	1 250	(4,100)
79,2 (260)	16	16	12	12			1 250	(4,100)	1 250	(4,100)
85,3 (280)	16	12	12				1 250	(4,100)	1 250	(4,100)
91,4 (300)	12	12					1 250	(4,100)	1 250	(4,100)

Note: Hoist line lengths are based on tandem drums both reeved to main load block. Each drum is dead ended in main load block reeving. Total parts of line requires using both drums 1 and 2.

Hoist line and whip line lengths given in table will allow hook to touch ground. When block travel below ground is required, add additional rope equal to parts of line times added travel distance. Hoisting distance or line pull may be limited when block travel below ground is required.

boom combinations

No. 80 Main Boom Combinations

Boom Length m (ft)	Boom Inserts	
	6,1 m (20 ft)	12,2 m (40 ft)
54,9 (180)	-	2
61,0 (200)	1	2
67,1 (220)	-	3
73,2 (240)	1	3
79,2 (260)	-	4
85,3 (280)	1	4
91,4 (300)	-	5
97,5 (320)	1	5
103,6 (340)	-	6
109,7 (360)	1	7
115,8 (380)	2	7

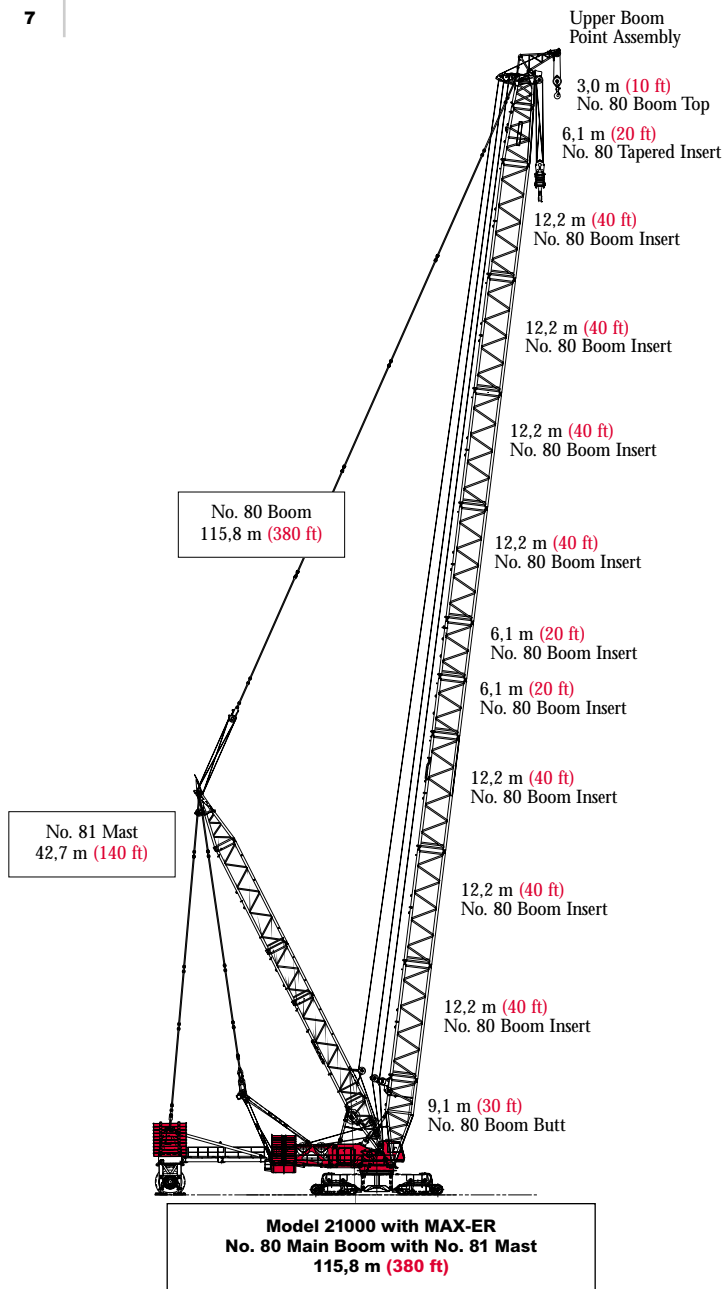

boom combinations

32

No. 81 Luffing Jib Combinations

Luffing Jib Length m (ft)	Boom Inserts	
	6,1 m (20 ft)	12,2 m (40 ft)
36,6 (120)	-	-
42,7 (140)	1	-
48,8 (160)	-	1
54,9 (180)	1	1
61,0 (200)	-	2
67,1 (220)	1	2
73,2 (240)	-	3
79,2 (260)	1	3
85,3 (280)	-	4
91,4 (300)	1	4

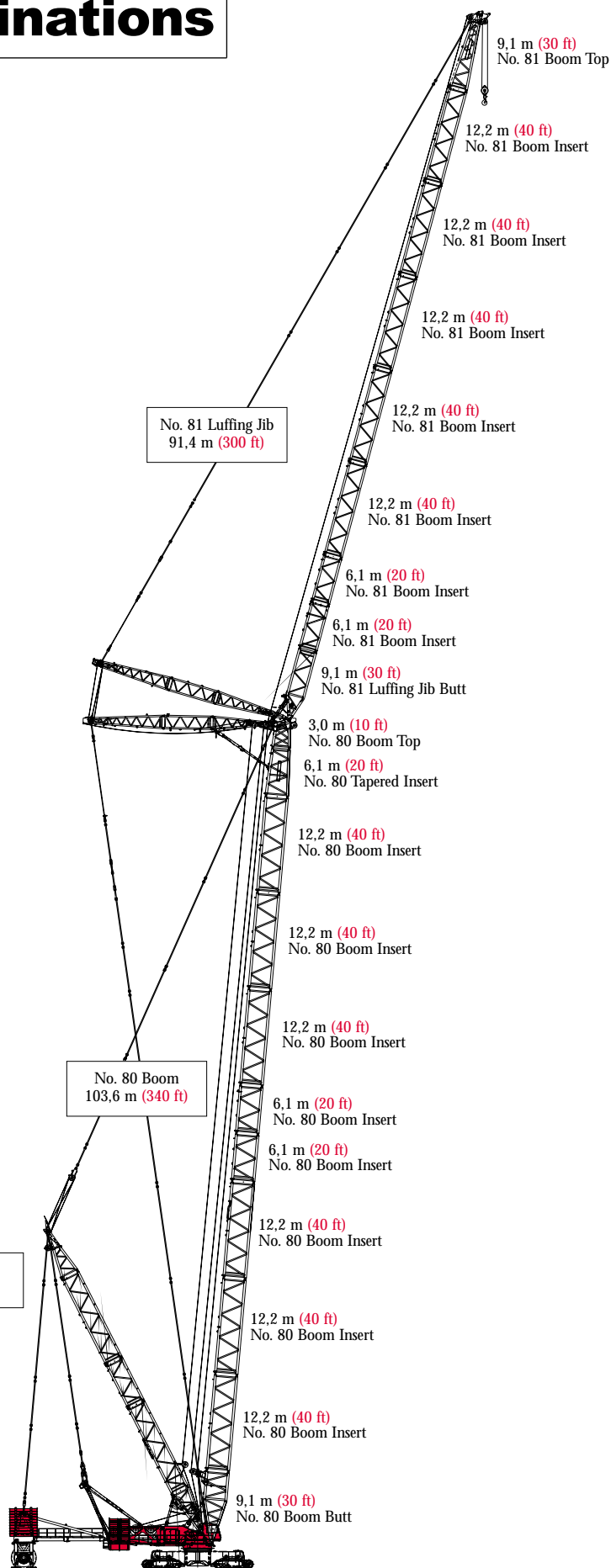

**Model 21000 with MAX-ER
No. 80 Main Boom with No. 81 Mast
with No. 81 Luffing Jib
195,0 m (640 ft)**

heavy-lift boom range diagram

No. 80 Heavy-Lift Boom with MAX-ER™

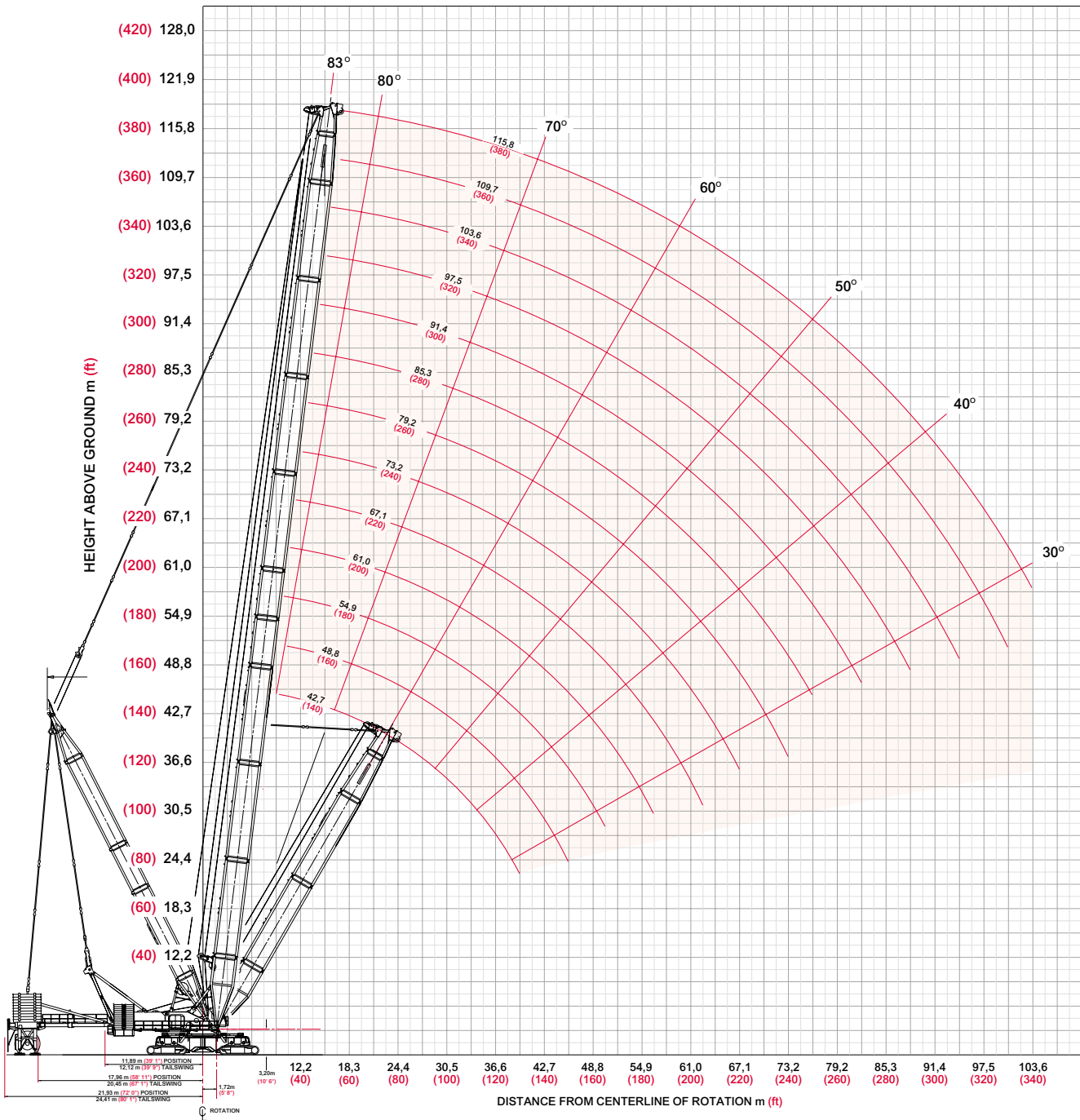

model 21000 with MAX-ER™



heavy-lift load charts

34

Liftcrane Boom Capacities - MAX-ER™ Boom No. 80 with 42,7 m (140') Mast

208 060 kg (458,700 lb) Counterweight 90 720 kg (200,000 lb) Carbody Counterweight

511 330 kg (1,127,300 lb) Hanging Counterweight

360° Rating for wide crawler arrangement or narrow crawler arrangement with outriggers

kg (lb) x 1 000

Boom m (ft)	42,7 (140)	48,8 (160)	54,9 (180)	61,0 (200)	67,0 (220)	73,2 (240)	85,3 (280)	91,4 (300)	97,5 (320)	103,6 (340)	109,7 (360)	115,8 (380)
Radius												
8,5 (28)	907,1 (2000.0)											
9,0 (32)	907,1 (2000.0)	- (2000.0)										
10,0 (36)	907,1 (2000.0)	907,1 (2000.0)	- (1941.3)	- (1863.9)								
12,0 (40)	907,1 (2000.0)	907,1 (2000.0)	880,5 (1941.3)	845,4 (1863.9)	796,7 (1756.5)	- (1641.6)						
14,0 (50)	899,7 (1911.9)	899,2 (1906.6)	877,3 (1903.0)	845,4 (1863.9)	796,2 (1753.7)	742,1 (1628.9)	618,9 (1356.3)	- (1247.8)	- (1103.8)			
18,0 (60)	734,2 (1593.4)	731,8 (1588.2)	730,3 (1584.8)	729,6 (1580.6)	731,4 (1576.3)	718,4 (1573.8)	605,3 (1332.3)	557,2 (1226.4)	500,6 (1103.8)	439,1 (968.1)	386,3 (851.7)	- (753.0)
20,0 (70)	660,2 (1362.8)	657,8 (1357.7)	656,3 (1354.3)	654,4 (1350.0)	652,4 (1345.6)	651,2 (1343.1)	598,1 (1307.8)	550,8 (1204.7)	500,6 (1103.8)	439,1 (968.1)	386,3 (851.7)	341,5 (753.0)
24,0 (80)	547,7 (1188.0)	545,5 (1183.1)	543,9 (1179.7)	541,9 (1175.3)	539,9 (1170.8)	538,7 (1168.2)	536,4 (1160.5)	529,6 (1155.7)	493,5 (1085.2)	439,1 (968.1)	386,3 (851.7)	341,5 (753.0)
26,0 (90)	504,1 (1051.0)	501,9 (1046.1)	500,3 (1042.8)	498,3 (1038.3)	496,3 (1033.7)	495,1 (1031.2)	491,6 (1023.4)	489,4 (1018.5)	486,6 (1021.7)	439,1 (968.1)	386,3 (851.7)	341,5 (753.0)
30,0 (100)	433,8 (940.6)	431,6 (935.8)	430,2 (932.6)	428,1 (928.0)	426,0 (923.4)	424,8 (920.8)	421,3 (913.0)	419,1 (908.1)	420,5 (911.4)	420,7 (906.4)	386,3 (851.7)	341,5 (753.0)
32,0 (110)	405,1 (849.7)	403,0 (845.1)	401,5 (841.9)	399,4 (837.3)	397,3 (832.6)	396,1 (830.0)	392,6 (822.2)	390,4 (817.3)	391,9 (820.6)	389,6 (815.6)	379,4 (812.0)	337,3 (727.7)
36,0 (120)	354,8 (764.4)	354,9 (769.1)	353,4 (766.0)	351,3 (761.3)	349,2 (756.6)	348,0 (754.0)	344,5 (746.2)	342,3 (741.3)	343,8 (744.6)	341,5 (739.6)	339,8 (736.0)	317,8 (694.6)
38,0 (130)	325,6 (667.0)	334,6 (704.5)	333,1 (701.4)	331,0 (696.8)	328,9 (692.1)	327,7 (689.5)	324,1 (681.6)	321,9 (676.7)	323,4 (680.0)	321,2 (675.1)	319,5 (671.4)	308,1 (661.9)
42,0 (140)		298,9 (645.7)	298,2 (645.9)	296,1 (641.3)	293,9 (636.5)	292,7 (633.9)	289,2 (626.1)	286,9 (621.2)	288,5 (624.5)	286,2 (619.5)	284,5 (615.9)	282,5 (610.9)
48,0 (160)			256,2 (554.3)	254,3 (550.5)	252,1 (545.8)	251,0 (543.3)	247,4 (535.4)	245,2 (530.5)	246,7 (533.9)	244,5 (528.9)	242,8 (525.3)	240,5 (520.2)
54,0 (180)				221,4 (478.7)	219,5 (474.8)	218,3 (472.3)	214,8 (464.5)	212,5 (459.6)	214,1 (463.0)	211,8 (458.0)	210,2 (454.4)	207,9 (449.4)
60,0 (200)					192,9 (415.5)	192,0 (415.2)	188,5 (407.5)	186,3 (402.6)	187,9 (406.1)	185,6 (401.1)	184,0 (397.5)	181,7 (392.5)
66,0 (220)						170,1 (365.0)	166,9 (360.5)	164,7 (355.7)	166,3 (359.2)	164,1 (354.3)	162,4 (350.7)	160,2 (345.7)
74,0 (240)							143,4 (321.2)	141,2 (316.4)	142,9 (320.0)	140,6 (315.1)	139,0 (311.6)	136,8 (306.6)
78,0 (260)								131,2 (282.9)	132,9 (286.7)	130,7 (281.8)	129,1 (278.3)	126,8 (273.3)
86,0 (280)									115,6 (257.9)	113,5 (253.1)	111,9 (249.6)	109,6 (244.7)
90,0 (300)										105,9 (228.0)	104,4 (224.7)	99,4 (210.2)
98,0 (320)											91,0 (202.7)	76,3 (171.3)
102,0 (340)												65,2 (133.9)

model 21000 with MAX-ER™



Meets ANSI B30.5 Requirements - Capacities do not exceed 75% of static tipping load.
NOTICE: This capacity chart is for reference only and must not be used for lifting purposes.

luffing jib range diagram

No. 81 Luffing Jib on No. 80 Boom with MAX-ER™

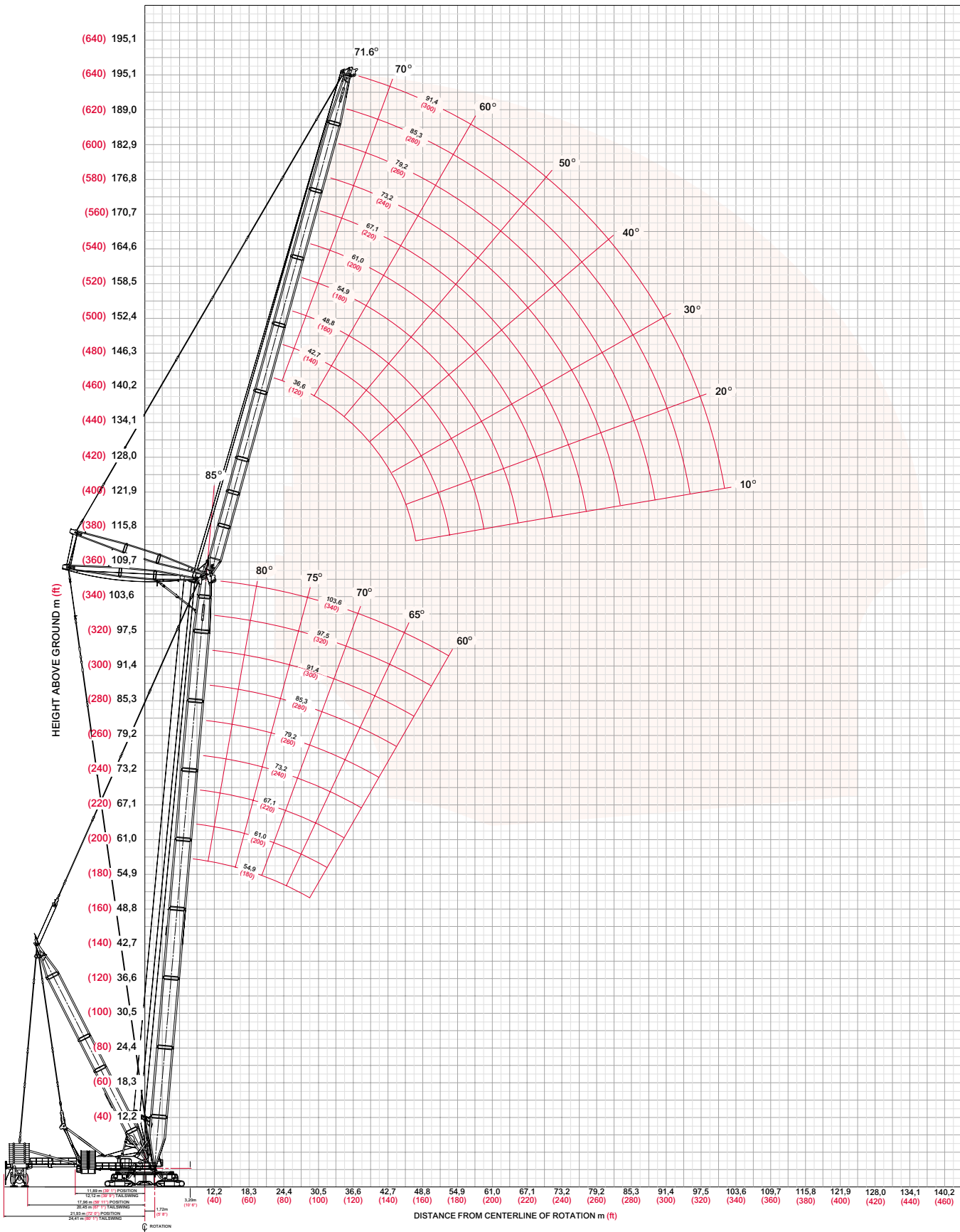

Luffing jib load charts

36

Liftcrane Luffing Jib Capacities - MAX-ER™

Luffing Jib No. 81 on Boom No. 80

224 390 kg (497,700 lb) Counterweight 90 720 kg (200,000 lb) Carbody Counterweight

509 840 kg (1,124,000 lb) Wheeled Counterweight

360° Rating for wide crawler arrangement or narrow crawler arrangement with outriggers kg (lb) x 1 000

85° Boom Angle

Boom m (ft)	54,9 (180)	67,1 (220)	79,2 (260)	91,4 (300)	103,6 (340)	Boom m (ft)	54,9 (180)	67,1 (220)	79,2 (260)	91,4 (300)	103,6 (340)
Radius						Radius					
18,3 (60)	453,5 (1000.0)					18,3 (60)					
20,0 (70)	451,1 (969.1)					20,0 (70)					
24,0 (80)	417,4 (913.3)	- (787.0)				24,0 (80)	339,8 (749.2)	- (622.1)			
30,0 (100)	372,1 (812.7)	317,6 (689.8)	270,2 (585.7)	229,4 (498.5)	- (415.9)	30,0 (100)	319,5 (696.3)	265,8 (579.7)	224,1 (488.4)	187,3 (411.9)	- (317.6)
36,0 (120)	300,3 (647.0)	253,5 (547.1)	219,3 (474.1)	190,3 (412.0)	164,3 (356.3)	36,0 (120)	272,6 (591.0)	227,7 (493.9)	193,8 (420.9)	165,4 (359.6)	139,9 (306.6)
42,0 (140)	233,8 (484.3)	205,8 (445.1)	180,4 (390.2)	158,5 (343.1)	138,7 (300.5)	42,0 (140)	226,7 (489.4)	190,3 (411.0)	164,0 (354.5)	141,6 (306.6)	122,1 (264.7)
48,0 (160)						48,0 (160)	187,0 (402.6)	158,0 (340.2)	137,4 (296.4)	120,0 (259.1)	104,7 (226.3)
54,0 (180)						54,0 (180)	155,5 (334.4)	132,0 (284.1)	115,8 (249.5)	102,0 (220.0)	89,8 (193.9)
60,0 (200)						60,0 (200)	132,9 (287.7)	113,1 (244.5)	99,7 (215.6)	88,2 (190.8)	78,1 (168.8)
64,0 (215)						64,0 (215)			94,1 (-)	82,5 (-)	72,7 (158.1)

Boom m (ft)	54,9 (180)	67,1 (220)	79,2 (260)	91,4 (300)	103,6 (340)	Boom m (ft)	54,9 (180)	67,1 (220)	79,2 (260)	91,4 (300)	103,6 (340)
Radius						Radius					
27,4 (90)	220,4 (486.1)					27,4 (90)					
30,0 (100)	220,4 (486.1)	191,0 (421.1)	- (357.5)	- (299.4)		30,0 (100)					
36,0 (120)	219,7 (483.4)	188,2 (410.2)	159,9 (349.8)	135,2 (297.6)	106,9 (235.7)	36,0 (120)	149,6 (330.0)	130,0 (286.7)	114,1 (251.6)	97,7 (215.6)	- (177.9)
44,0 (150)	190,9 (405.7)	161,0 (341.8)	137,9 (293.2)	118,1 (251.3)	100,6 (214.5)	44,0 (150)	140,9 (299.4)	130,0 (283.3)	113,0 (243.7)	96,6 (208.4)	78,4 (172.5)
54,0 (180)	151,4 (326.7)	127,1 (274.3)	109,6 (236.7)	94,6 (204.6)	81,5 (176.3)	54,0 (180)	112,1 (242.2)	112,8 (244.3)	96,9 (210.4)	82,8 (179.9)	70,2 (152.6)
64,0 (210)	118,0 (260.1)	99,0 (218.3)	85,9 (189.5)	74,8 (165.0)	65,0 (143.3)	64,0 (210)	87,1 (192.1)	88,9 (196.0)	80,0 (176.4)	68,5 (151.0)	58,2 (128.4)
72,0 (240)	97,7 (210.2)	82,2 (176.8)	71,6 (154.2)	62,7 (135.1)	54,7 (118.0)	72,0 (240)	70,4 (150.3)	72,1 (154.3)	67,9 (146.2)	58,2 (125.3)	49,5 (106.8)
80,0 (270)		71,4 (-)	62,2 (135.6)	54,4 (117.6)	47,5 (102.3)	80,0 (270)	56,0 (115.6)	57,7 (119.2)	57,6 (121.5)	49,5 (104.3)	42,1 (89.0)
88,0 (300)						88,0 (300)	44,1 (87.5)	45,6 (90.4)	47,0 (93.6)	42,5 (88.5)	36,2 (75.5)
100,0 (330)						100,0 (330)			33,0 (72.1)	33,8 (73.5)	30,7 (67.6)

model 21000 with MAX-ER™



Meets ANSI B30.5 Requirements - Capacities do not exceed 75% of static tipping load.
 NOTICE: This capacity chart is for reference only and must not be used for lifting purposes.

Luffing jib load charts

Liftcrane Luffing Jib Capacities - MAX-ER™

Luffing Jib No. 81 on Boom No. 80

224 390 kg (497,700 lb) Counterweight 90 720 kg (200,000 lb) Carbody Counterweight

509 840 kg (1,124,000 lb) Wheeled Counterweight

360° Rating for wide crawler arrangement or narrow crawler arrangement with outriggers kg (lb) x 1 000

75° Boom Angle

37

Boom m (ft)	54,9 (180)	67,1 (220)	79,2 (260)	91,4 (300)	103,6 (340)
Radius					
34,0 (110)	369,6 (826.6)				
36,0 (120)	348,1 (754.8)	- (736.4)			
40,0 (130)	311,4 (693.5)	303,9 (676.8)	295,9 (658.8)		
44,0 (150)	281,1 (594.6)	274,4 (580.4)	267,1 (565.1)	- (520.2)	
50,0 (170)	244,1 (516.7)	238,5 (505.4)	232,4 (492.4)	219,8 (469.3)	186,0 (397.8)
56,0 (190)		209,1 (433.3)	204,4 (433.3)	196,7 (418.1)	167,1 (355.0)
64,0 (210)					141,6 (312.3)
72,0 (230)					
80,0 (250)					
- (270)					

Boom m (ft)	54,9 (180)	67,1 (220)	79,2 (260)	91,4 (300)	103,6 (340)
Radius					
34,0 (110)					
36,0 (120)					
40,0 (130)					
44,0 (150)	276,6 (585.2)	- (569.5)			
50,0 (170)	240,7 (510.2)	234,1 (496.4)	225,1 (481.7)	- (415.6)	
56,0 (190)	212,1 (450.4)	206,4 (438.2)	200,3 (425.2)	179,9 (387.2)	147,2 (317.3)
64,0 (210)	182,1 (401.5)	177,1 (390.6)	171,9 (379.0)	161,2 (355.5)	132,2 (291.6)
72,0 (230)	- (359.7)	153,9 (350.6)	149,4 (340.4)	142,7 (324.2)	116,6 (265.3)
80,0 (250)			- (306.8)	124,1 (293.4)	101,5 (239.7)
- (270)					- (214.2)

Boom m (ft)	54,9 (180)	67,1 (220)	79,2 (260)	91,4 (300)	103,6 (340)
Radius					
50,0 (160)	213,7 (475.4)				
54,0 (180)	205,6 (448.5)	196,8 (433.9)			
60,0 (200)	188,7 (409.5)	186,0 (402.7)	171,0 (374.3)	144,4 (316.4)	
68,0 (220)	163,6 (367.2)	160,6 (360.1)	155,3 (348.3)	134,6 (299.8)	110,2 (245.6)
76,0 (250)	140,7 (309.2)	140,4 (308.6)	135,7 (298.3)	122,6 (269.8)	100,0 (220.0)
84,0 (280)	121,4 (261.9)	123,8 (267.5)	119,6 (258.5)	110,4 (239.0)	89,3 (193.1)
92,0 (310)		103,5 (221.3)	105,8 (221.3)	96,2 (201.7)	79,0 (167.4)
100,0 (340)					68,8 (151.1)
112,0 (370)					
120,0 (390)					

Boom m (ft)	54,9 (180)	67,1 (220)	79,2 (260)	91,4 (300)	103,6 (340)
Radius					
50,0 (160)					
54,0 (180)					
60,0 (200)	121,6 (262.9)	124,5 (270.7)			
68,0 (220)	101,6 (229.3)	107,9 (242.7)	111,1 (248.7)	102,0 (225.0)	
76,0 (250)	83,0 (182.1)	89,7 (196.9)	95,5 (209.8)	98,5 (216.4)	85,3 (187.8)
84,0 (280)	66,7 (141.9)	72,9 (155.3)	79,1 (168.5)	84,1 (179.9)	78,9 (171.3)
92,0 (310)	53,1 (108.8)	58,4 (120.0)	63,9 (131.5)	69,3 (143.2)	71,5 (152.6)
100,0 (340)	41,7 (82.4)	46,2 (91.2)	50,8 (100.7)	55,8 (110.9)	60,4 (120.9)
112,0 (370)			35,5 (76.7)	39,1 (84.3)	43,0 (92.8)
120,0 (390)					34,1 (77.5)

Meets ANSI B30.5 Requirements - Capacities do not exceed 75% of static tipping load.
 NOTICE: This capacity chart is for reference only and must not be used for lifting purposes.

Luffing jib load charts

38

Liftcrane Luffing Jib Capacities - MAX-ER™

Luffing Jib No. 81 on Boom No. 80

224 390 kg (497,700 lb) Counterweight 90 720 kg (200,000 lb) Carbody Counterweight

509 840 kg (1,124,000 lb) Wheeled Counterweight

360° Rating for wide crawler arrangement or narrow crawler arrangement with outriggers kg (lb) x 1 000

65° Boom Angle

Luffing Jib Length	Boom					Luffing Jib Length	Boom					
	m (ft)	54,9 (180)	67,1 (220)	79,2 (260)	91,4 (300)		103,6 (340)	m (ft)	54,9 (180)	67,1 (220)	79,2 (260)	91,4 (300)
36,6 m (120 ft)	Radius						Radius					
	50,0 (160)	232,1 (525.9)					50,0 (160)					
	52,0 (170)	222,2 (491.9)					52,0 (170)					
	58,0 (190)	196,4 (433.8)	188,1 (415.5)	179,1 (395.6)			58,0 (190)					
	64,0 (210)		167,7 (369.7)	159,9 (352.5)	150,9 (332.8)		64,0 (210)	171,3 (377.8)	162,9 (359.2)			
	70,0 (230)			143,4 (315.7)	135,7 (298.7)	126,7 (279.0)	70,0 (230)	154,2 (339.5)	146,6 (322.8)	138,5 (304.9)		
	76,0 (250)				122,2 (268.6)	114,5 (251.7)	76,0 (250)	139,5 (306.6)	132,7 (291.7)	125,4 (275.6)	117,3 (257.8)	
	82,0 (270)					- (226.6)	82,0 (270)		116,7 (264.5)	110,5 (250.2)	103,3 (234.0)	95,3 (216.0)
	88,0 (290)						88,0 (290)			103,8 (227.4)	97,1 (213.0)	89,7 (196.6)
	94,0 (310)						94,0 (310)				85,5 (193.8)	79,4 (179.3)
100,0 (330)						100,0 (330)					74,5 (162.8)	

Luffing Jib Length	Boom					Luffing Jib Length	Boom					
	m (ft)	54,9 (180)	67,1 (220)	79,2 (260)	91,4 (300)		103,6 (340)	m (ft)	54,9 (180)	67,1 (220)	79,2 (260)	91,4 (300)
73,2 m (240 ft)	Radius						Radius					
	70,0 (225)	149,2 (337.3)					70,0 (225)					
	74,0 (235)	139,5 (320.1)					74,0 (235)					
	80,0 (250)	126,7 (296.8)	119,6 (280.4)	112,1 (-)			80,0 (250)	91,8 (-)				
	88,0 (270)	112,1 (269.6)	105,8 (254.5)	99,1 (238.5)	91,7 (-)		88,0 (270)	76,1 (192.5)	85,0 (-)			
	96,0 (300)	99,6 (235.0)	94,0 (221.7)	88,0 (207.5)	81,3 (192.0)	74,1 (175.1)	96,0 (300)	61,4 (153.6)	70,6 (174.1)	78,9 (188.8)		
	108,0 (330)		- (194.0)	73,8 (181.7)	68,3 (167.8)	62,0 (152.6)	108,0 (330)	43,3 (119.1)	50,8 (138.1)	59,0 (157.4)	62,8 (154.7)	55,2 (131.0)
	116,0 (360)				- (147.0)	54,1 (133.4)	116,0 (360)	- (90.8)	40,1 (106.6)	47,0 (124.1)	54,6 (135.0)	49,3 (119.0)
	124,0 (390)					- (110.9)	124,0 (390)		- (81.3)	37,1 (95.3)	43,4 (111.1)	43,0 (103.7)
	132,0 (420)						132,0 (420)				34,7 (85.1)	36,3 (87.6)
136,0 (450)						136,0 (450)					32,6 (69.3)	

model 21000 with MAX-ER™



Meets ANSI B30.5 Requirements - Capacities do not exceed 75% of static tipping load.
 NOTICE: This capacity chart is for reference only and must not be used for lifting purposes.

CraneCARE is Manitowoc's comprehensive service and support program. It includes classroom and on-site training, prompt parts availability, expert field service, technical support and documentation — for every one of the more than 7,000 Manitowoc cranes currently in use throughout the world.

That's commitment you won't find anywhere else.

That's CraneCARE.

Service Training

Manitowoc specialists work with you in our training center and in the field to make sure you know how to get maximum performance, reliability, and life from your cranes.

Manitowoc Cranes Technical Training Center provides valuable multi-level training, which is available for all models and attachments, in the following format:

- Basic – Provides technicians with the basic skills required in our Level I and II classes covering hydraulic and electrical theory and schematics, pump, motor, control, and LMI operation, and the use of meters and gauges.
- Level 1 – This model-specific class covers theory and offers hands-on training and trouble shooting for all crane systems.
- Level 2 – This model-specific class provides in depth coverage of all crane systems and components, and advanced troubleshooting of simulated faults. (Requires Level 1.)
- Level 3/Masters – Covering all EPIC® models and the 4100W, this class stresses high level system knowledge and trouble shooting of simulated faults. (Requires Level 2.)

Parts Availability

Genuine Manitowoc replacement parts are accessible through your distributor 24 hours a day, 7 days a week, 365 days a year.

Service Interval Kits

Provides all the parts required by Manitowoc's Preventative Maintenance Checklist.

Hydraulic Filter Kit – Part No. 495139-0

Consists of the following:

- Filter Element - No substitutions allowed (1x Part No. 427264-0)

Caterpillar Model 3406C Diesel – Part No. 414150-0

Service Interval Kits

200 Hour Kit – Part No. 495203-0

Consists of the following:

Engine

- Air Cleaner - Disposable (1x Part No. 347066-0)
- Oil Filter (1x Part No. 413202-0)
- Water Filter (1x Part No. 413211-0)
- Fuel Filter - Final (1x Part No. 413216-0)
- Fuel Filter - Primary (1x Part No. 413213-0)

1,000 Hour Kit – Part No. 495234-0

Consists of the following:

Engine

- Air Cleaner - Disposable (1x Part No. 347066-0)
- Oil Filter (1x Part No. 413202-0)
- Water Filter (1x Part No. 413211-0)
- Fuel Filter - Final (1x Part No. 413216-0)
- Fuel Filter - Primary (1x Part No. 413213-0)

Hydraulic

- Filter Element - No substitutions allowed (1x Part No. 427264-0)

2,000 Hour Kit – Part No. 495205-0

Consists of the following:

Engine

- Air Cleaner - Disposable (1x Part No. 347066-0)
- Oil Filter (1x Part No. 413202-0)
- Water Filter (1x Part No. 413211-0)
- Fuel Filter - Final (1x Part No. 413216-0)
- Fuel Filter - Primary (1x Part No. 413213-0)
- Belt - Alternator (1x Part No. 412610-0)

Hydraulic

- Filter Element - No substitutions allowed (1x Part No. 427264-0)
- Filter - Hydraulic In-tank Suction (2x Part No. 427258-0)
- Seal Kit (1x Part No. 427258-5)

Hydraulic Test Kit – Part No. 499791-6

Protect your investment by demanding Genuine Manitowoc Parts Service Kits. The Hydraulic Service Kit consist of the following:

- All hydraulic fittings to access all pressures and flows
- Hydraulic flow meters and pressure gauges to record hydraulic data.
- Electrical "Break out" harnesses to access voltages on all electrical circuits on all machines.
- Fluke® Digital volt ohm meter, as used in all Manitowoc service literature.

Hydraulic Test Kit with case – Part No. 499792-9

The above kit (Part No. 4299791-6) plus a custom heavy-duty carrying case.

U.S. Standard Tools Kit – Part No. 22205-1

All standard tools needed to properly maintain and service your crane. (Does not include torque wrench.)

Field Service

Factory-trained service experts are always ready to help maintain your crane's peak performance.

CraneCARESM

For a worldwide listing of dealer locations, please consult our website at: www.manitowoccranes.com

40

Technical Support

Manitowoc's dealer network and factory personnel are available 24 hours a day, 7 days a week, 365 days a year to answer your technical questions and more, with the help of computerized programs that simplify crane selection, lift planning, and ground-bearing calculations.

For a worldwide listing of dealer locations, please consult our website at: www.manitowoccranes.com

Technical Documentation

Manitowoc has the industry's most extensive documentation, and the easiest to understand, available in major languages and formats that include print, disk, and videotape.

A complete set of Operator's, Parts, Capacity, Vendor, and Service Technician's Manuals are shipped with each crane.

Additional copies available through your Authorized Manitowoc Distributor.

- Crane Operator's Manual – Part No. 899721
- Crane Parts Manual – Part No. 899720
- Crane Capacity Manual – Part No. 899794
- Attachments Capacity Manual – Part No. 899795
- Crane Vendor Manual – Part No. 899722
- Service Technician's Manual (EPIC®) – Part No. 899732

CD rom versions of the Operator's and Parts Manuals are shipped with each crane.

Also available are the following CDs:

- 21000 Service – Yearly subscription
CD – Part No. 899809-0
- Ground Bearing Pressure Estimator
CD – Part No. 899765-0
- Crane Selection and Planning Software (CompuCRANE®)
CD – Part No. 899766-0
- EPIC® Crane Library consisting of capacity charts, range diagrams, wire rope specifications, travel specifications, crane weights, counter weight arrangement, luffing jib raising procedures, operating range diagrams, drum and lagging charts, and wind condition charts.
CD – Part No. 899801-0

Available from your Authorized Manitowoc Cranes Distributor, these VHS videos are available in NTSC, PAL and SECAM formats.

- Model 21000 Assembly Video – Part No. 899836
- Model 21000 Operation Video – Part No. 899837
- Model 21000 Lubrication Video – Part No. 899838

- Your Capacity Chart Video – Part No. 899737
- Respect the Limits Video – Part No. 899734
- Crane Safety Video – Part No. 899736
- Boom Inspection/Repair Video – Part No. 899738

CraneCARE Package

Manitowoc has assembled all of the available literature, CD's, and videos listed above plus several Manitowoc premiums into one complete CraneCARE Package.



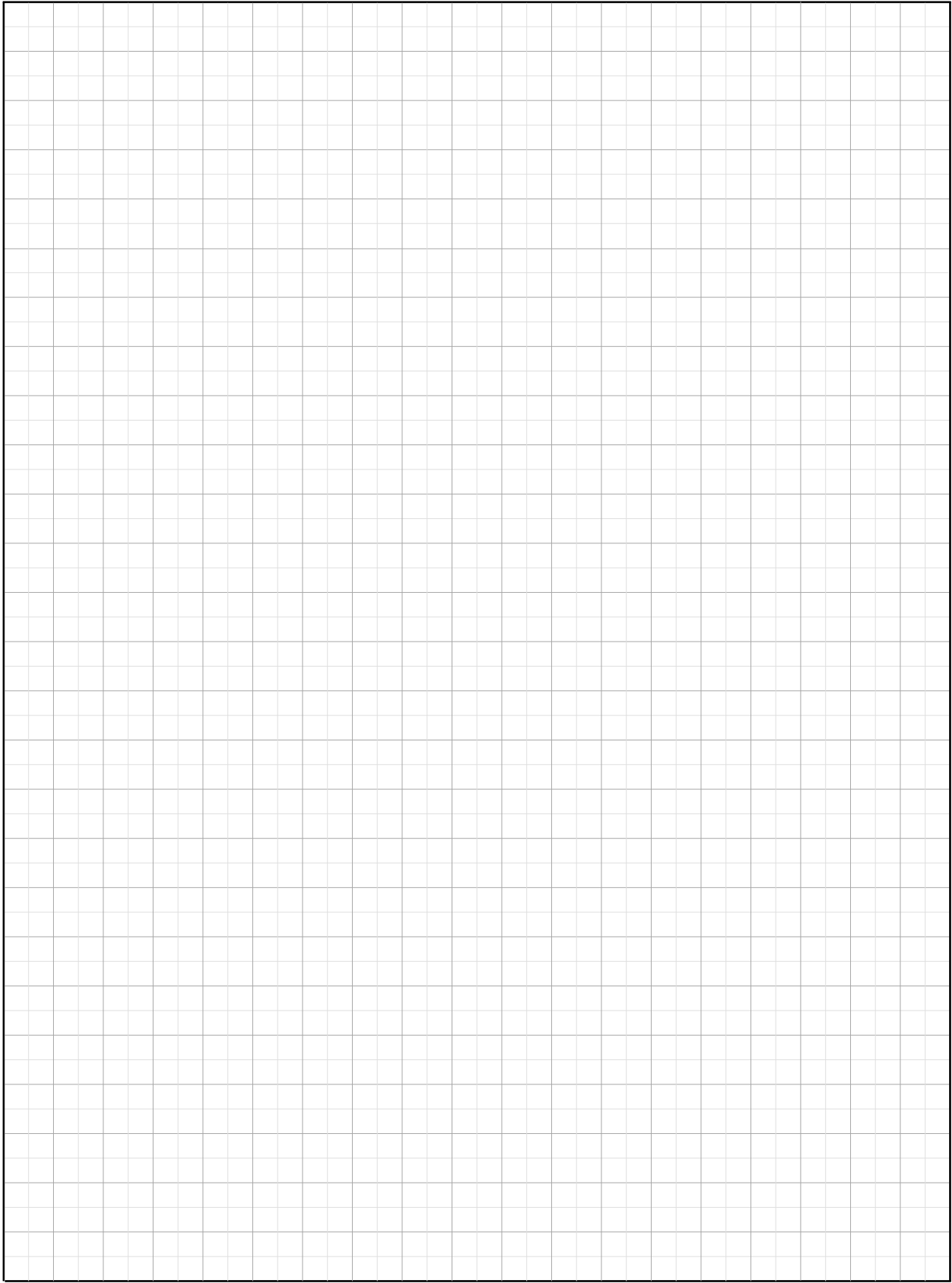

Notes

42

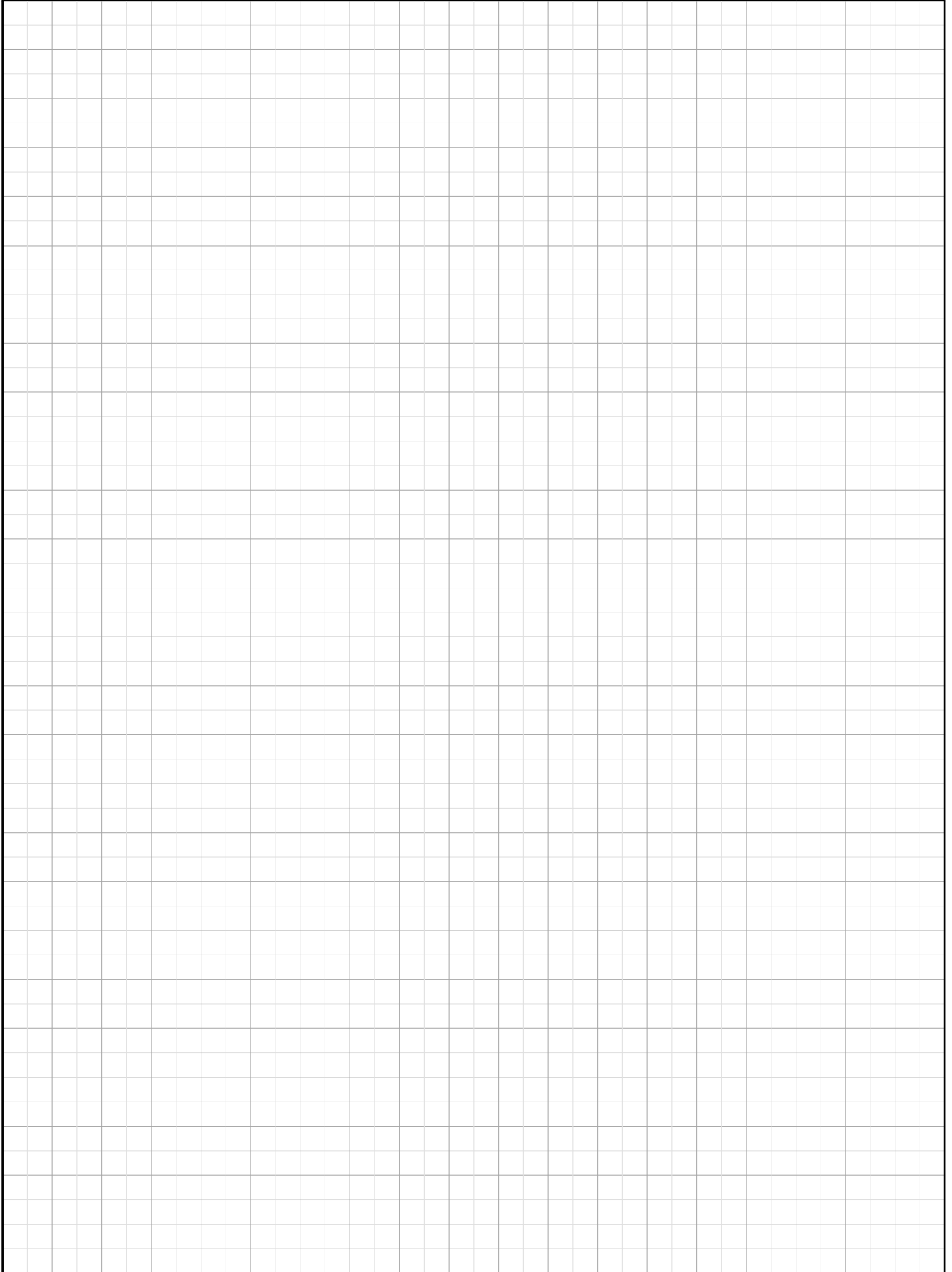

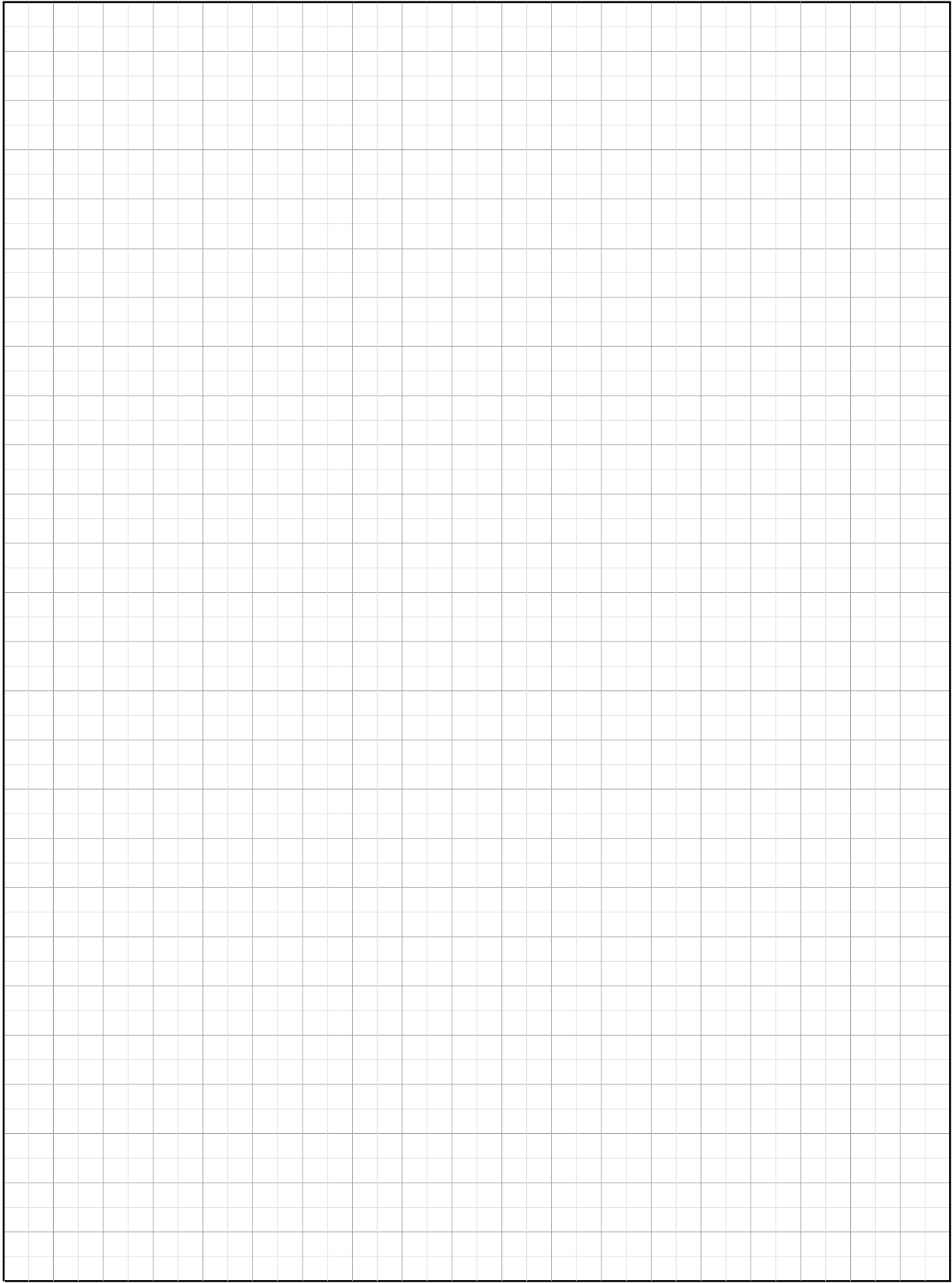



Backed by Manitowoc

CraneCARESM

CraneCARE is Manitowoc's comprehensive service and support program. It includes classroom and on-site training, prompt parts availability, expert field service, technical support and documentation — for every one of the more than 7,000 Manitowoc cranes currently in use throughout the world. That's commitment you won't find anywhere else. That's CraneCARE.



Manitowoc Cranes, Inc.
P.O. Box 70
Manitowoc, WI, USA 54221-0070
Telephone 920-684-6621
Facsimile 920-683-6277
www.manitowoccranes.com