

Technical Data

Specifications & Capacities

248

HYLALAB

HSL Crawler Crane
200 Ton (181.4 metric ton)

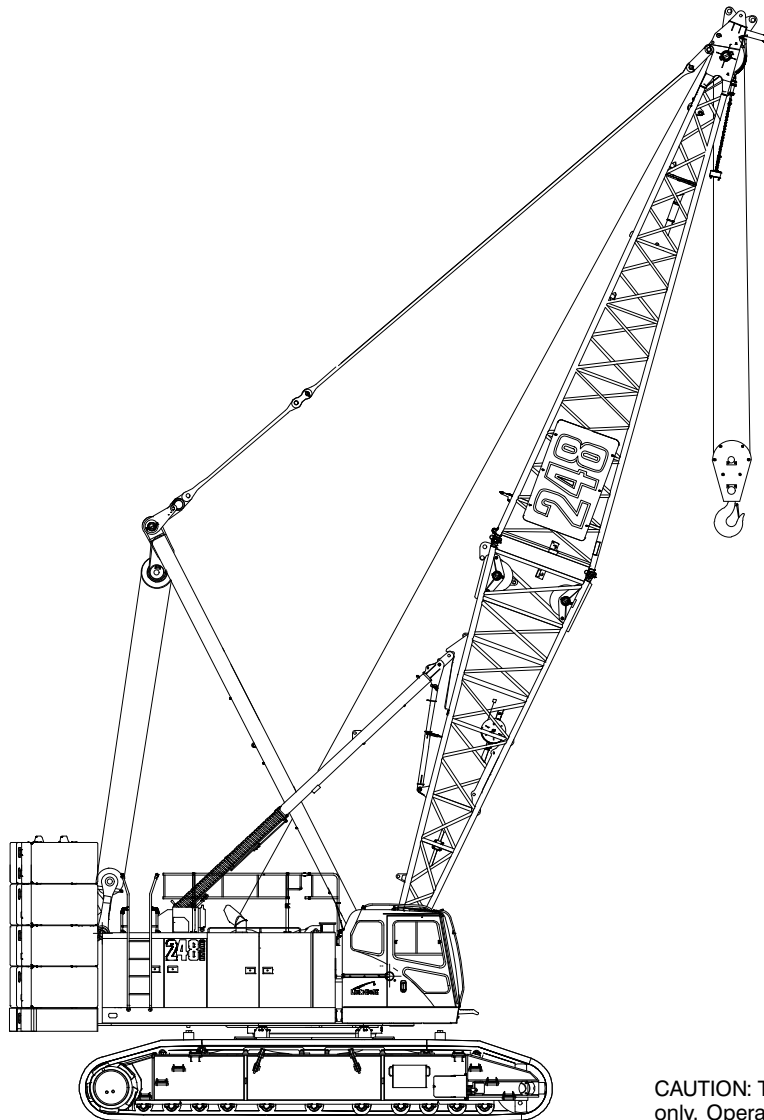

CAUTION: This material is supplied for reference use only. Operator must refer to in-cab Crane Rating Manual and Operator's Manual to determine allowable crane lifting capacities and assembly and operating procedures.

Table Of Contents

Upper Structure	1
Engine	1
Frame	1
Hydraulic System	1
Load Hoist Drums	1
Optional Front-Mounted Third Hoist Drum	1
Boom Hoist Drum	2
Swing System	2
Counterweight	2
Operator Cab	2
Rated Capacity Limiter System	2
Boom Hoist System	2
Machinery House	2
Catwalks	2
Lower Structure	3
Carbody	3
Side Frames	3
Counterweight	3
Travel and Steering	3
Jack System	3
Attachment and Options	3
Conventional Tube Boom	3
Tubular Jib	4
Luffing Boom	4
Auxiliary Tip Extension	4
Luffing Jib	4
Fixed Jib	4
Dimensions	5
Base Crane	7
Side Frames	7
Upper Counterweights	8
Lower Counterweights	8
Boom/Luffing Boom	9
Jib	11
Luffing Jib	12
Hook Balls	13
Hook Blocks	13
Working Weights	15
Transport Weights	16
Transport Drawings	17
Load Hoist Performance	20
Working Areas	21
Attachments	22
Main Boom Make-up	23
Main Boom Working Range Diagram	24
Main Boom Load Charts	25
Jib Attachment Working Range Diagram	27
Jib Attachment Load Charts	28

This Page Intentionally Blank

Upper Structure

Engine

Engine

Full pressure lubrication, oil filter, air cleaner, hour meter, throttle, and electric control shutdown.

Cummins Tier4 Final QSB6.7

Number of cylinders	6
Bore and stroke	4.20 x 4.88 in (107 x 124mm)
Piston displacement	408 in ³ (6.7L)
Engine rpm at full load speed	2,000 rpm
Hi-idle rpm	2,000 rpm
Gross engine hp	270 hp (201kw)
Peak torque	730 ft lb (990joule) @ 1,500 rpm
Electrical system	24 volt
Fuel tank capacity	122 gal (460L)
Batteries	2–12 volt
Approximate fuel consumption	gal/hr (L/hr)
100% hp	12.62 (47.77)
75% hp	10.57 (40.01)
50% hp	7.57 (28.66)
25% hp	4.16 (15.75)

Fuel Tank

Equipped with fuel sight level gauge.

Frame

All welded and precision machined surfaces for mating parts.

Turntable Bearing

- Inner race with internal swing gear is bolted to lower frame.
- Outer race is bolted to upper frame.

Hydraulic System

Hydraulic Pumps

The pump arrangement is designed to provide hydraulically powered functions allowing positive, precise control with independent or simultaneous operation of all crane functions.

- Two variable displacement pumps operating at 4,553 psi (320kg/cm²) and 70.3 gal/min (266L/min) powers load hoist drums, boom hoist drum, optional third drum, and travel.
- One variable displacement pump operating at 2,987 psi (210kg/cm²) and 40.2 gal/min (152L/min) powers the swing motors, lower jacks, counterweight removal, and side frame extend/retract.
- One fixed displacement gear type pump operating at 1,422 psi (100kg/cm²) and 10.3 gal/min (39L/min) powers the pilot control system, clutches, brakes, and pump controls.
- Two fixed displacement gear type pumps operating at 10.3 gal/min (39L/min) powers the hoist brake cooling system.

Hydraulic Reservoir

84.5 gal (320L), equipped with sight level gauge. Diffusers built in for deaeriation.

Filtration

Ten micron, full flow, line filter in the control circuit. Oil is filtered prior to entering the reservoir.

Counterbalance Valves

All hoist motors are equipped with counterbalance valves to provide positive load lowering and prevent accidental load drop if the hydraulic pressure is suddenly lost.

Load Hoist Drums

Each drum contains an axial piston variable speed hydraulic motor with individual automatic winch motor brakes. Power flow is directed through a “wet” style multi-disc brake.

- Power up/down
- Automatic brake mode (spring applied, hydraulically released, wet type brake)
- Drum laggings grooved for wire rope
- Drum pawls controlled manually
- Electronic drum rotation indicators
- Mounted on anti-friction bearings
- 21.81 in (55.40cm) root diameter
- 37.80 in (96.01cm) flange diameter
- 25.26 in (64.16cm) width
- Optional free fall drum

Optional Front-Mounted Third Hoist Drum

Mounts in the boom base section and is used in conjunction with a fleeting sheave and 3-sheave idler assembly to run the wire rope over the boom top section.

- Power up/down for luffer applications where a second load line is needed
- 18.70 in (475mm) root diameter
- 33.66 in (855mm) flange diameter
- 32 in (813mm) width
- Mounted on anti-friction bearings
- High and low speed

Boom Hoist Drum

Contains a pilot controlled, bi-directional, axial piston motor and a planetary gear reduction unit to provide positive control under all load conditions.

- Spring applied, hydraulically released, disc type brake controlled automatically
- Drum lagging grooved for wire rope
- Electronic drum rotation indicators
- Drum pawl controlled automatically
- Mounted on anti-friction bearings
- 20.89 in (53.06cm) root diameter
- 36.22 in (92.00cm) flange diameter
- 11.57 in (29.39cm) width

Swing System

Pilot controlled bi-directional axial piston motors and planetary gear reduction units to provide positive control under all load conditions.

- Spring applied, hydraulically released, 360° multi-plate brake
- Free swing mode when lever is in neutral position
- Four position positive house lock
- Two-speed swing
- Audio/Visual swing alarm
- Maximum swing speed is 1.7 rpm

Counterweight

Upper counterweight consists of a eleven-piece design that can be easily lowered to the ground using the removal cylinders.

- “A” upper counterweight consists of one 20,000 lb (9 072kg) base slab.
- “B” upper counterweight consists of one 15,000 lb (6 804kg) and one 14,200 lb (6 441kg) wing weights.
- “C” upper counterweight consists of one 15,000 lb (6 804kg) and one 14,200 lb (6 441kg) wing weights.
- “D” upper counterweight consists of one 15,000 lb (6 804kg) and one 14,200 lb (6 441kg) wing weights.
- “E” upper counterweight consists of one 15,000 lb (6 804kg) and one 14,200 lb (6 441kg) wing weights.

Total combined upper counterweight “ABCDE” is 137,840 lb (62 523kg).

Operator Cab

Fully enclosed modular steel compartment is independently mounted and padded to protect against vibration and noise.

- All tinted/tempered safety glass
- Sliding entry door
- 18,750 BTU/hr hot water heater
- 15,880 BTU/hr air conditioner
- Door and window locks
- Circulating fan
- Sun visor
- Cloth seat
- Windshield wipers and washer
- Dry chemical fire extinguisher
- Electronic drum rotation indicators for front, rear, and boom hoist drums
- Six way adjustable seat
- Hand and foot throttle
- Fully adjustable single axis controls
- Swing lever with swing brake and horn located on handle
- Bubble type level
- Ergonomic gauge layout
- Controls shut off lever
- Control stand is adjustable for operator comfort.
- Swing brake foot pedal

Rated Capacity Limiter System

The HSL rated capacity limiter system is a boom hoist load cell system. This system provides the operator with useful geometrical data, to include:

- Main Boom Length
- Main Boom Angle
- Jib Length
- Jib Angle
- Operating Mode
- Load Radius
- Boom Tip Height
- Audible Alarm
- Pre-Warning Light
- Overload Light
- Load On Hook
- Function kick-outs including over load
- Operator settable stops (ramped stops)
- Anti-Two Block Indicator
- Boom hoist dead end load cell (no lineriders)

Boom Hoist System

Designed to lift off maximum boom or maximum boom plus jib unassisted. Operates up to a maximum boom angle of 82° for conventional boom and 88° for luffing boom. Boom hoist limit system limits maximum boom angle operation.

- Pin-on bail frame
- 16-part reeving with 7/8 in (22mm) wire rope
- 27 ft (8.23m) live mast
- Tubular boom backstops (telescopic type)
- Sheaves contain sealed anti-friction bearings

Machinery House

Hinged doors (on right and left sides) for machinery access. Equipped with rooftop access ladder and skid resistant finish on roof.

Catwalks

Standard on right and left sides. Catwalks fold up and pin for reduced travel width.

Lower Structure

Carbody

Lower Frame

All welded construction frame with precision machined surfaces for turntable bearing and rotating joint.

- 9 ft 3 in (2.82m) overall width
- 15 ft 10 in (4.83m) overall length

Side Frames

Side Frames

All welded, precision machined, hook and pinned steel frames

- 18 ft 10 in (5.74m) gauge
- 31 ft 3.3 in (9.53m) overall length
- 44 in (1.12m) wide track shoes
- Sealed (oil filled) drive planetaries
- Compact travel drives
- Automatic hydraulic track adjustment system – optional

Track Rollers

- Eleven sealed (oil filled) track rollers per side frame
- Heat treated, mounted on oil filled anti-friction bearings

Tracks

Heat treated, self-cleaning, multiple hinged track shoes joined by one-piece full floating pins; 54 shoes per side frame

Take Up Idlers

Cast steel, heat treated, self-cleaning, mounted on aluminum/bronze bushings. Lubricated through idler shaft.

- **Track Tension Adjustment** – Idler wheel adjusted by means of hydraulic cylinder and hand pump. Idler wheel shaft held in position with shims after adjustment is made.

Counterweight

Lower counterweight consists of two 17,650 lb (8 005kg) counterweights that attach to the jack cylinders.

Travel and Steering

Travel and Steering

Each side frame contains a pilot controlled, bi-directional, axial piston motor and a planetary gear reduction unit to provide positive control under all load conditions.

- Individual control provides smooth, precise maneuverability including full counter-rotation.
- Spring applied, hydraulically released disc type brake controlled automatically
- Maximum travel speed is 1 mph (1.6km/h).
- Designed to 30% gradeability

Jack System

System contains four hydraulic cylinders individually pinned on swing out beams.

- Individual controls are mounted on carbody.
- Minimum height of carbody when resting on pontoons is 18.5 in (0.47m).
- Maximum height of carbody when resting on pontoons is 43.7 in (1.11m).

Attachment and Options

Conventional Tube Boom 55–285 ft (16.76–86.87m)

Basic Boom

55 ft (16.76m) two-piece design that utilizes a 25 ft (7.62m) base section and a 30 ft (9.14m) open throat top section with in-line connecting pins on 80 in (2.03m) wide and 68 in (1.73m) deep centers.

- Boom foot on 53.15 in (1.35m) centers
- 4 in (10.16cm) diameter chords
- Lugs on base section to attach carrying links
- Deflector roller on top section
- Permanent skid pads mounted on top section to protect head machinery
- Self-assembly sheaves mounted in 25' (7.62m) base section

- Six 21.53 in (54.69cm) root diameter polyamide sheaves mounted on sealed anti-friction bearings
- Tip extension and jib connecting lugs on top section
- Mechanical boom angle indicator

Tube Boom Extensions

The following table provides the lengths available and the suggested quantity to obtain maximum boom in 10 ft (3.05m) increments. Midpoint pendant connections are required at 135 ft (41.15m) for boom lengths of 255 ft (77.72m) and longer.

- Polyamide wear blocks on top of each extension
- Appropriate length bar pendants stored on each extension.
- Lifting lugs
- Maximum tip height of 287 ft (87.47m)
- Boom connecting pins storage on each extension

Type	Tube Boom Extensions		Qty For Max Boom
	ft	m	
FE	10	3.05	0
	20	6.10	1
	30	9.14	1
	40	12.19	1
JE2	10	3.05	1
	20	6.10	1
	30	9.14	1
	40	12.19	2

Tubular Jib 30–100 ft (9.14–30.48m)

Basic Tubular Jib

30 ft (9.14m) two-piece design that utilizes a 15 ft (4.57m) base section and a 15 ft (4.57m) top section with in-line connecting pins on 32 in (0.81m) wide and 24 in (0.61m) deep centers.

- 2.25 in (57.15mm) diameter tubular chords
- One 20.62 in (52.37cm) root diameter steel sheave mounted on sealed anti-friction bearings
- 10 ft (3.05m) and 20 ft (6.10m) jib extensions provide jib lengths of 40 ft (13.72m) to 100 ft (30.48m) in 10 ft (3.05m) increments for tube boom.
- Jib offset angles at 5°, 15°, and 25°
- The maximum tip height of tube boom + jib [245 ft + 100 ft (74.68 + 30.48m)] is 347 ft (105.76m).
- Can be used as fixed jib on luffing jib

Luffing Boom 100–160 ft (30.48–48.77m)

100 ft (30.48m) five-piece design utilizes a 5 ft (1.52m) luffing boom top section, 25 ft (7.62m) luffing boom base section, 10 ft (3.05m) bail anchor section, 10 ft (3.05m) extension, and 40 ft (12.19m) extension with in-line connecting pins. Boom extensions are 80 in (2.03m) wide and 68 in (1.73m) deep at the centers.

- Common base and extensions as open throat boom ("JE2" boom only)
- 10 ft (3.05m) bail anchor section
- Working angles of 88°, 85°, 80°, 75°, 70°, and 65°
- Working lengths of 100 ft (30.48m) to 160 ft (48.77m).

Luffing Boom Extensions

The following table provides the lengths available and the suggested quantity to obtain the maximum luffing boom in 10 ft (3.05m) increments. Midpoint pendants are not required.

Luffing Boom Extensions "JE2"		Quantity For Max Boom
ft	m	
10*	3.05	2
20	6.10	0
30	9.14	1
40	12.19	2

* One 10 ft (3.05m) bail anchor section required for luffer operation.

- Rear hoist drum becomes luffing jib hoist
 - Optional third drum provides second working hoist line, if required.
 - Designed for self-assembly
 - Luffing jib hoist bridle and bail can remain reeved for crane transport
 - Job site mobility with attachment
 - Rolled out or rolled under erection methods
 - Compact transport module

Auxiliary Tip Extension

Designed to use in place of jib to provide clearance between working hoist lines. The extension is equipped with two nylon 18 in (45.72cm) root diameter sheaves mounted on sealed anti-friction bearings. Maximum capacity is 18.5 Ton (16.78mt).

Luffing Jib 80–180 ft (24.38–54.86m)

Basic Luffing Jib

80 ft (24.38m) four-piece design utilizes a 10 ft (3.05m) luffing jib base section, 20 ft (6.10m) extension, 30 ft (6.10m) extension, and 20 ft (6.10m) top section with in-line connecting pins. Jib extensions are 64.88 in (1.65m) wide and 55 in (1.40m) deep at the centers.

- 47.5 Ton (43.1mt) maximum capacity
- Working lengths of 80 ft (24.38m) to 180 ft (54.86m)

- Top section includes mounting lugs for all attachment options
- Lugs on base section to attach fanpost transport links
- Two polyamide 21 in (53.34cm) root diameter luffing jib head sheaves
- Two polyamide 21 in (53.34cm) diameter luffing boom auxiliary head sheaves
- Pin-on nose wheel
- Eight-part luffing jib hoist
- 1.38 in (3.51cm) diameter type "N" pendants

Luffing Jib Extensions

The following table provides the lengths available and the suggested quantity to obtain the maximum luffing jib in 10 ft (3.05m) increments. Midpoint pendants are not required.

Luffing Jib Extensions		Quantity For Max Luffing Jib
ft	m	
20	6.10	2
30	9.14	1
40	12.19	2

Notes:

These extensions, combined with extensions included in basic luffing jib make up all luffing jib lengths to 160 ft (48.77m).

40 ft (12.19m) of extensions included in basic jib.

- Wear bar on top of each extension
- Appropriate length pendants
- Maximum luffing jib tip height of 332.14 ft (101.23m)

Fixed Jib 30 ft (9.14m)

30 ft (9.14m) two-piece design that utilizes a 15 ft (4.57m) base section and a 15 ft (4.57m) top section with in-line connecting pins on 32 in (0.81m) wide and 24 in (0.61m) deep centers.

- 2.25 in (57.15mm) diameter chords
- One 20.62 in (52.37cm) root diameter steel sheave mounted on sealed anti-friction bearings
- Fixed jib offset angle is 5°

Dimensions

General Dimensions	English	Metric
Basic Boom	55 ft	16.76m
Minimum Load Radius	12 ft	3.66m
Maximum Boom Angle	82°	82°
Track Shoe Width	44 in	1.12m

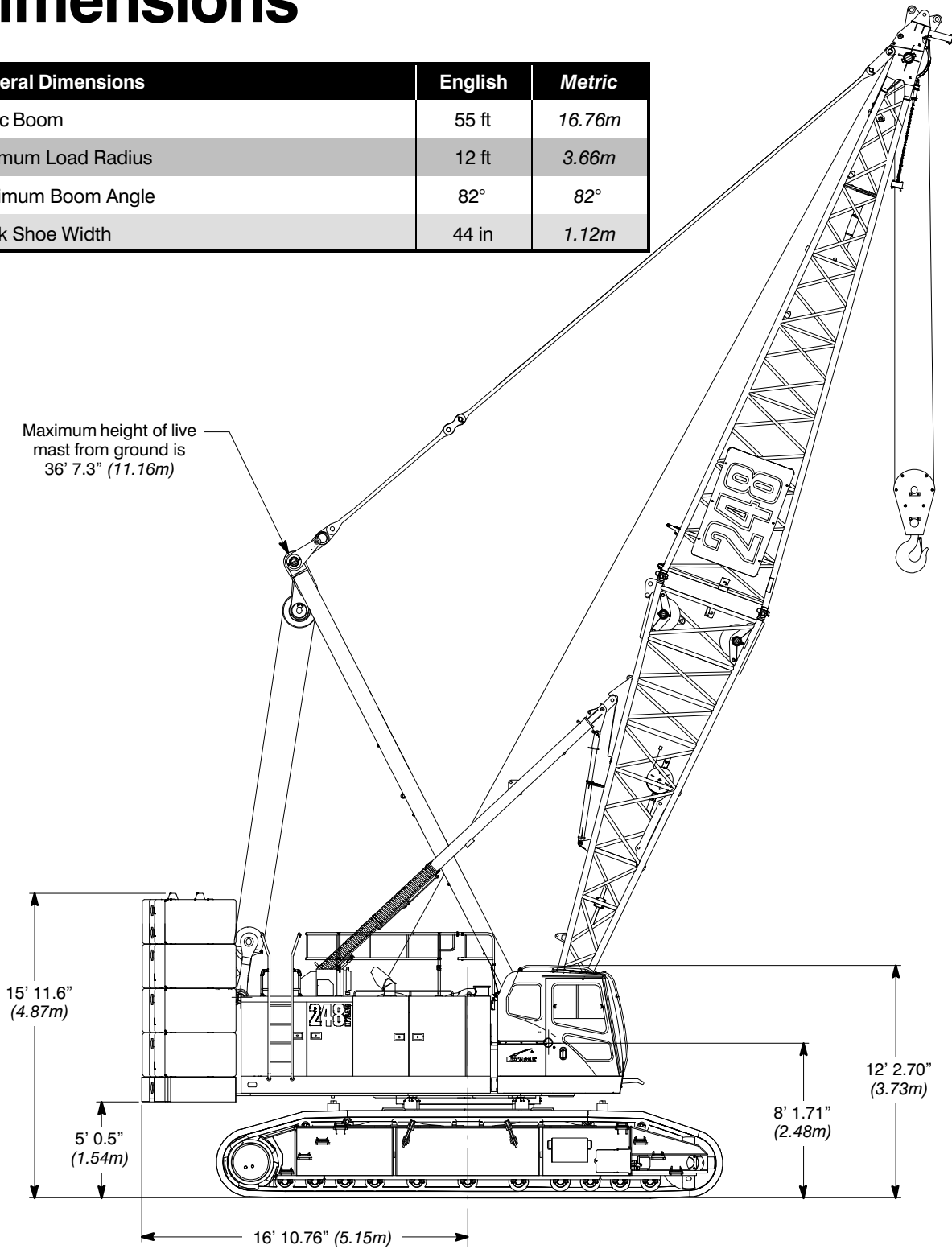

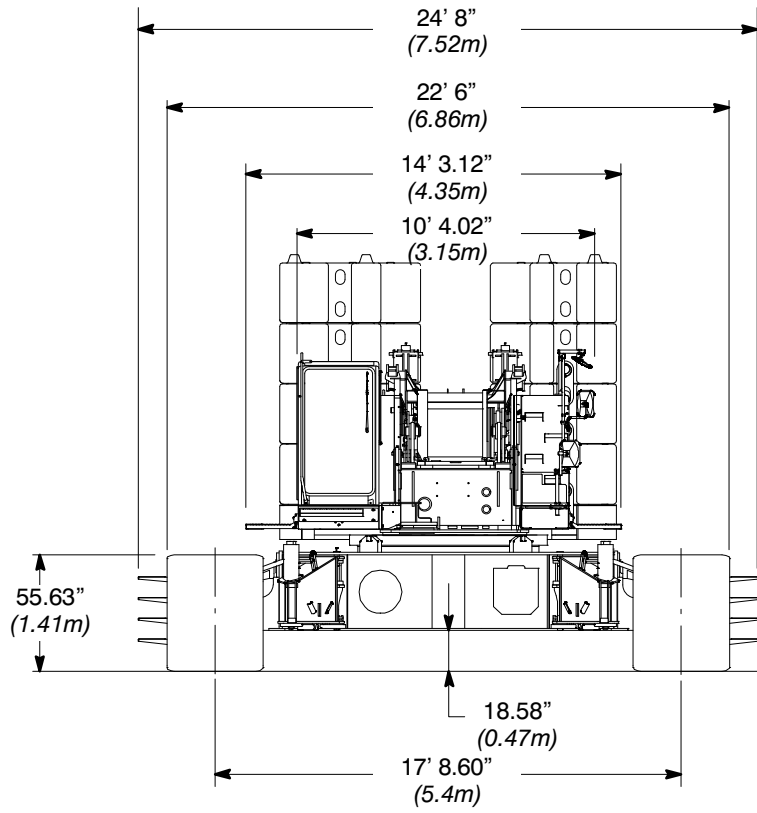
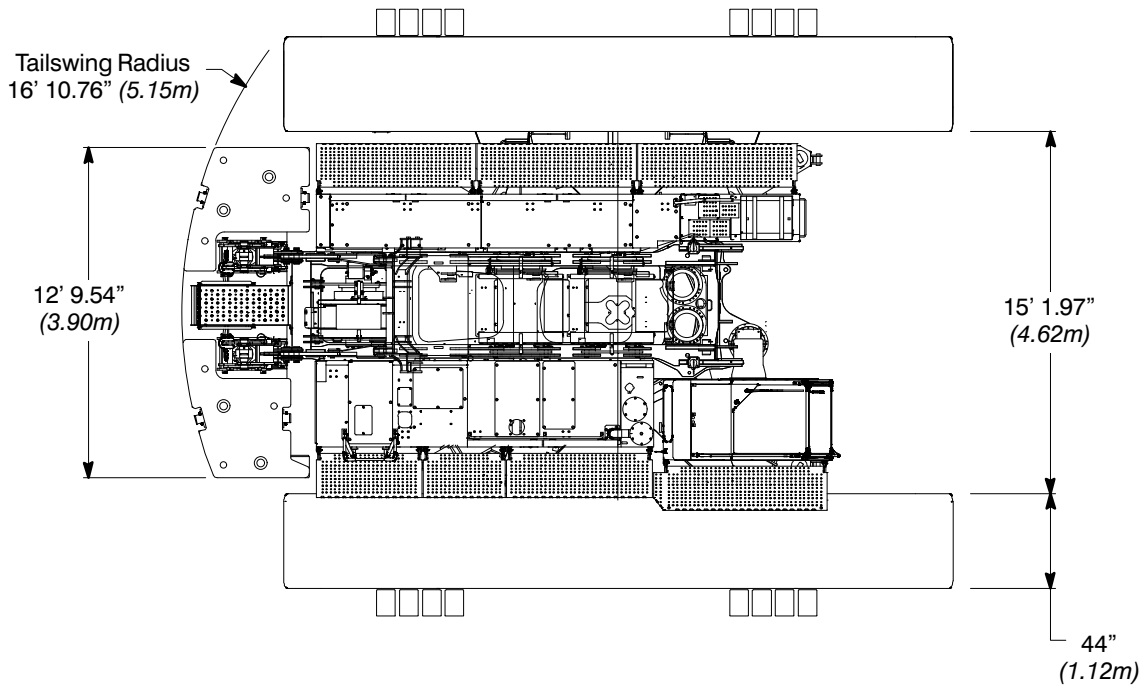

Base Crane

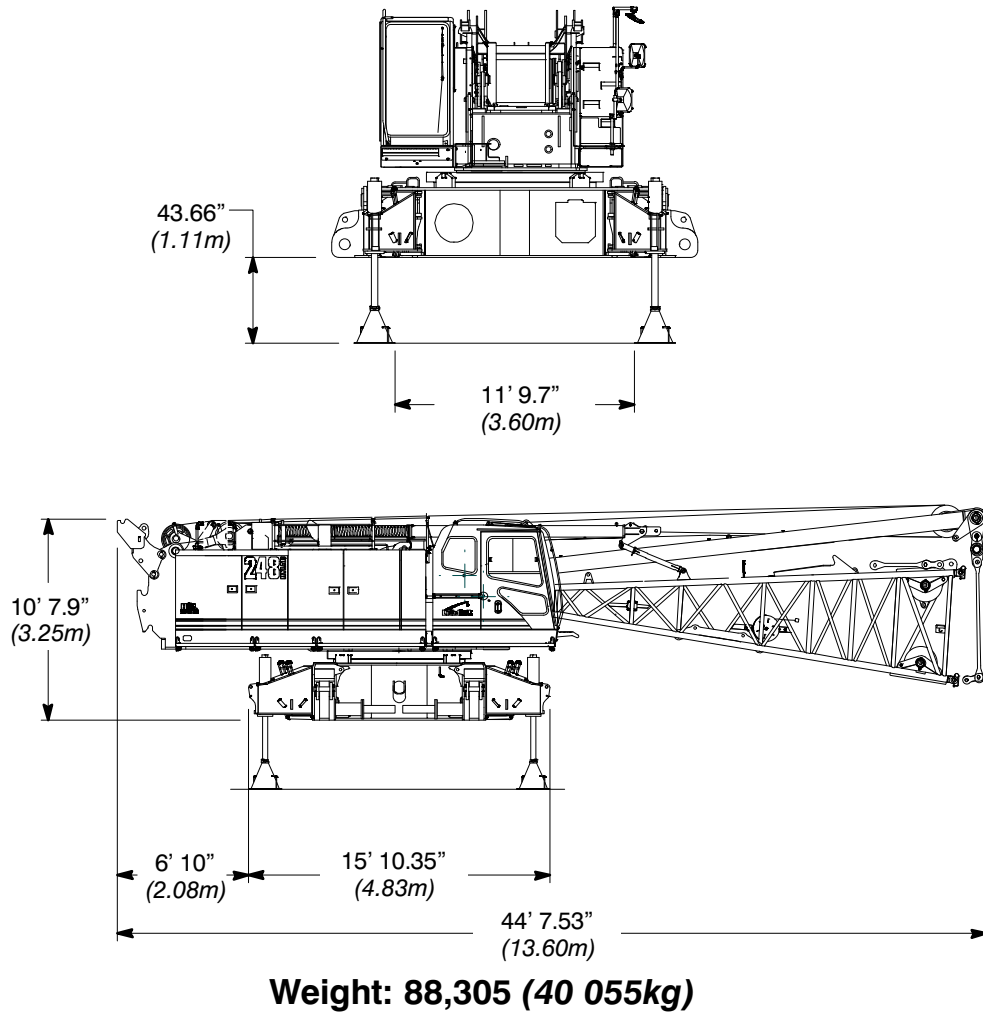

Side Frames

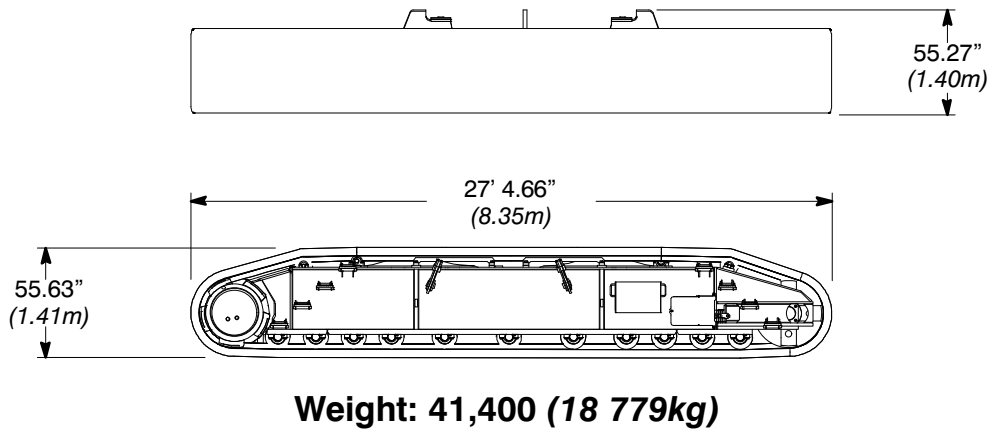

Upper Counterweights

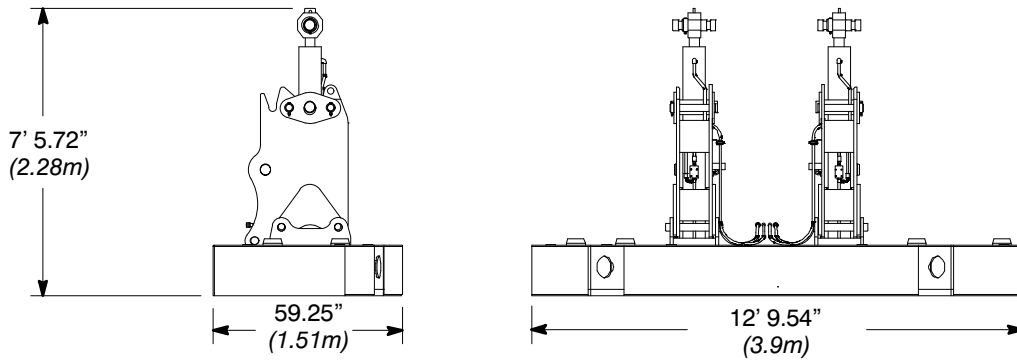

“A” Counterweight: 20,000 lb (9 072kg)

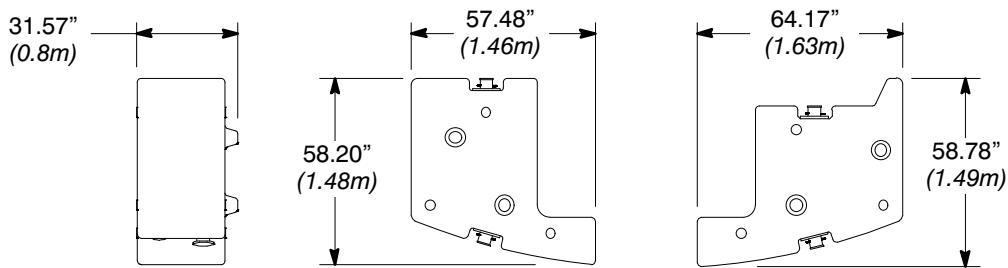

**“B”, “C”, “D”, & “E” Counterweight:
Left Side 15,000 lb (6 804kg)
Right Side 14,200 lb (6 441kg)**

Lower Counterweights

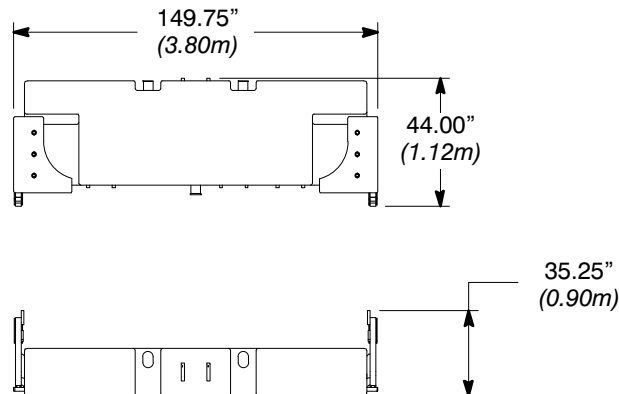

**Carbody Counterweights:
Front 17,650 lb (8 006kg)
Rear 17,650 lb (8 006kg)**

Boom/Luffing Boom

80 in (2.03m) x 68 in (1.73m)

Boom/Luffing Boom Extensions

Weights include pendants and hardware

Note: JE2 extensions for luffing boom use only.

10 ft (3.05m) Extension

FE Weight: 1,221 lb (554kg)

JE2 Weight: 1,439 lb (653kg)

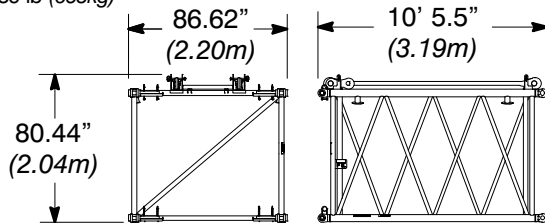

20 ft (6.10m) Extension

FE Weight: 1,961 lb (890kg)

JE2 Weight: 2,382 lb (1 080kg)

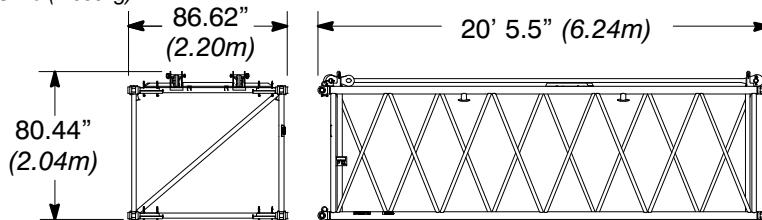

30 ft (9.14m) Extension

FE Weight: 2,681 lb (1 216kg)

JE2 Weight: 3,341 lb (1 515kg)

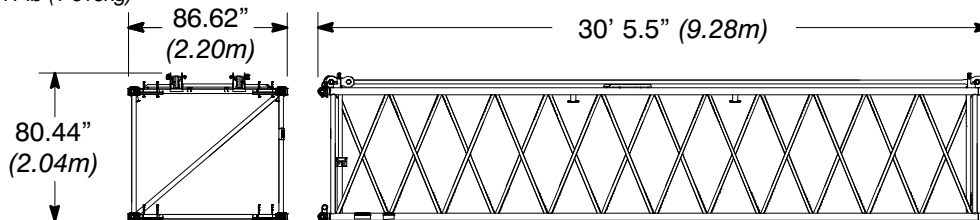

40 ft (12.19m) Extension

FE Weight: 3,457 lb (1 568kg)

JE2 Weight: 4,339 lb (1 968kg)

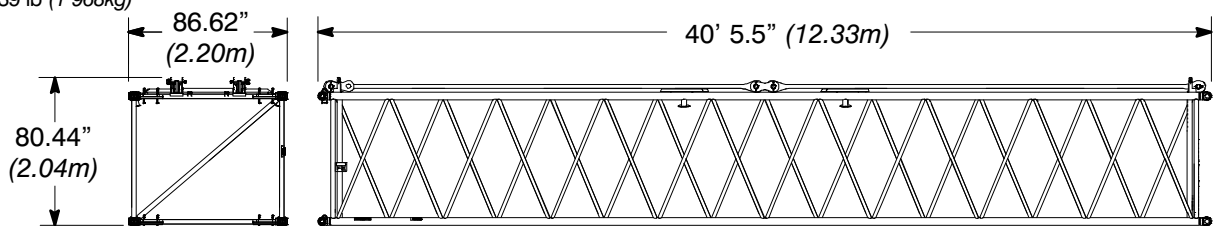

30 ft (9.14m) Boom Top Section ①

Length	32 ft 10 in	(10.01m)
Width	83.98 in	(2.13m)
Deep	68 in	(1.73m)
Height	81.14 in	(2.06m)
Weight	4,658 lb	(2 113kg)

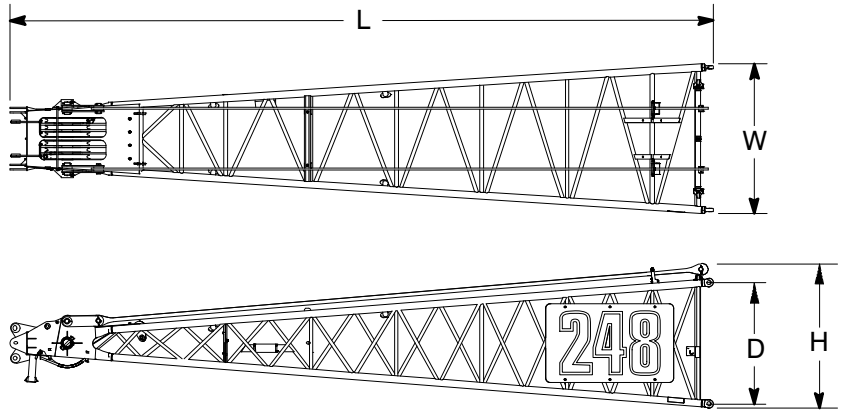

20 ft (6.10m) Boom Base Section ①

Length	25 ft 8.31 in	(7.83m)
Width	86.38 in	(2.19m)
Deep	68 in	(1.72m)
Height	79.3 in	(2.01m)
Weight	5,303 lb	(2 405kg)

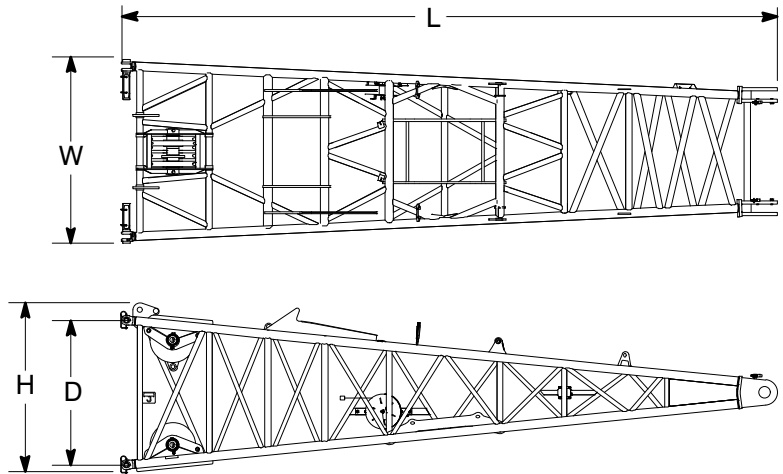

Auxiliary Tip Extension* ①

Length	68.38 in	(1.74m)
Width	23.00 in	(0.58m)
Height	41.12 in	(1.04m)
Weight	736 lb	(334kg)

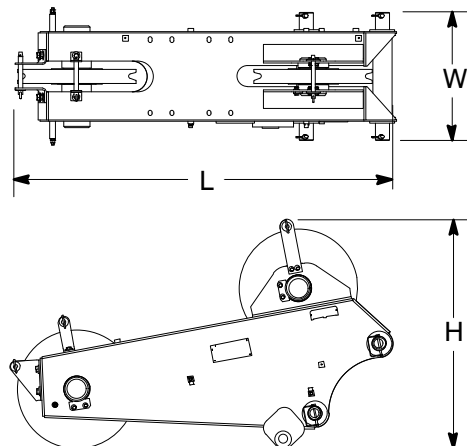

Number inside black circle “①” = # of components
 * – Optional equipment

Jib

15 ft (4.57m) Jib

Top Section* ❶

Length	16 ft 6.62 in	(5.04m)
Width	34.25 in	(0.87m)
Height	26.81 in	(0.68m)
Weight†	631 lb	(286kg)

† Weight includes pendants and hardware.

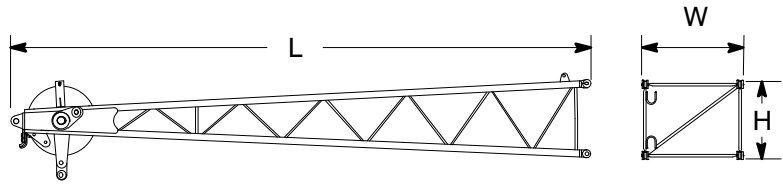

15 ft (4.57m) Jib

Base Section* ❶

Length1	18 ft 4.86 in	(5.61m)
Length2	15 ft 3.50 in	(4.66m)
Width	34.25 in	(0.87m)
Height 1	27.03 in	(0.69m)
Height 2	76.16 in	(1.93m)
Weight†	1,697 lb	(770kg)

† Weight includes pins, basic frontstay & backstay pendants, and hardware.

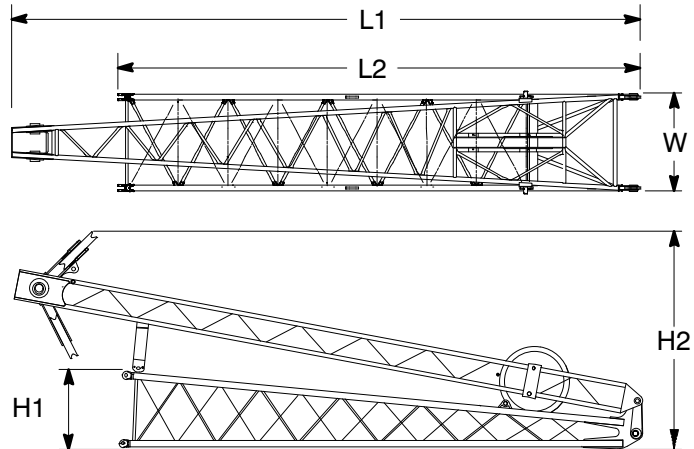

10 ft (3.05m) Jib

Extensions* ❶

Length	10 ft 0.76 in	(3.12m)
Width	34.25 in	(0.87m)
Height	26.75 in	(0.68m)
Weight†	226 lb	(103kg)

† Weights includes pins, pendants, and hardware.

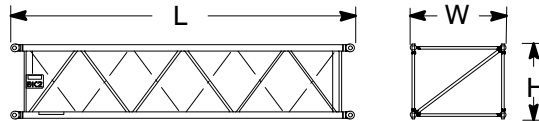

20 ft (6.10m) Jib

Extensions* ❶

Length	20 ft 0.22 in	(6.17m)
Width	34.25 in	(0.87m)
Height	26.75 in	(0.68m)
Weight†	396 lb	(180kg)

† Weights includes pins, pendants, and hardware.

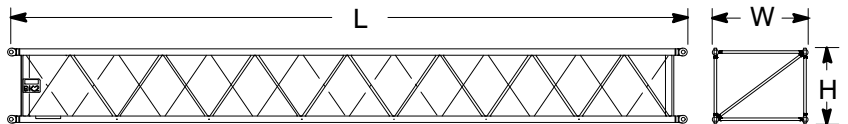

Number inside black circle “❶” = # of components

* — Optional equipment

Luffing Jib

10 ft (3.05m) Luffing Jib Base Section* ①

Length	10 ft 6 in	(3.20m)
Width	7 ft 9 in	(2.36m)
Height	57 in	(1.45m)
Weight†	1,259 lb	(571kg)

† Weight includes pendants and hardware.

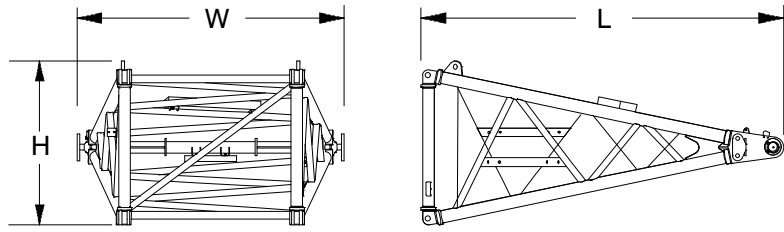

20 ft (6.10m) Luffing Jib Top Section* ①

Length	22 ft 2 in	(6.75m)
Width	63 in	(1.60m)
Height	56.75 in	(1.44m)
Weight†	2,416 lb	(1 096kg)

† Weight includes pendants and hardware.

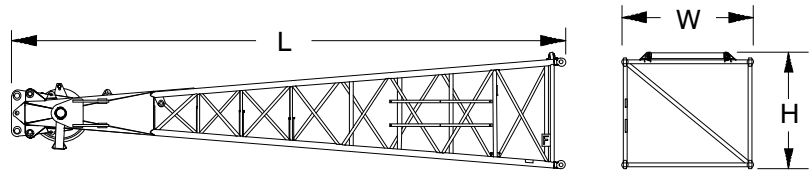

Luffing Jib Extensions*

Weights include pins, pendants, and hardware

10 ft (3.05m) Extension

Length	10 ft 5.5 in	(3.19m)
Width	65 in	(1.65m)
Height	54 in	(1.37m)
Weight†	541 lb	(245kg)

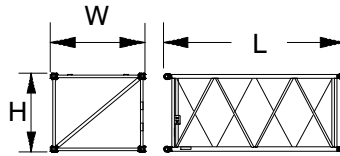

20 ft (6.10m) Extension

Length	20 ft 5.5 in	(6.24m)
Width	65 in	(1.65m)
Height	54 in	(1.37m)
Weight†	962 lb	(436kg)

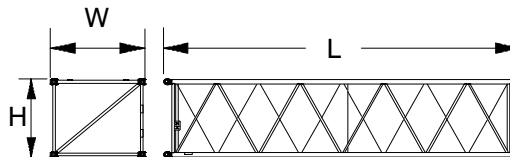

30 ft (9.14m) Extension

Length	30 ft 5.5 in	(9.28m)
Width	65 in	(1.65m)
Height	54 in	(1.37m)
Weight†	1 383 lb	(627kg)

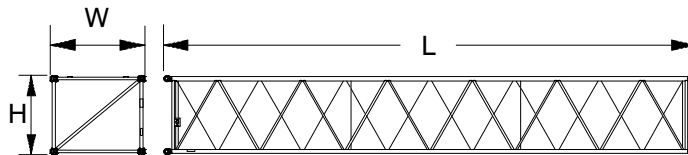

40 ft (12.19m) Extension

Length	40 ft 5.5 in	(12.33m)
Width	65 in	(1.65m)
Height	54 in	(1.37m)
Weight†	1 804 lb	(818kg)

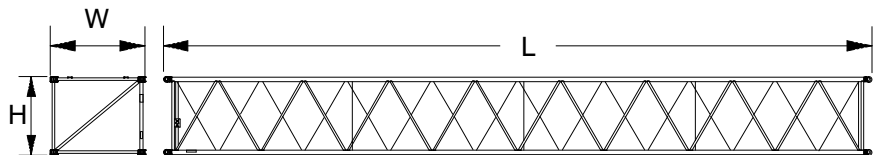

Number inside black circle “①” = # of components

* – Optional equipment

Hook Balls

15 Ton (13.6mt) Swivel Hook Ball* ①

Width	21.62 in	(0.55m)
Height	40.54 in	(1.03m)
Weight	1,211 lb	(549kg)

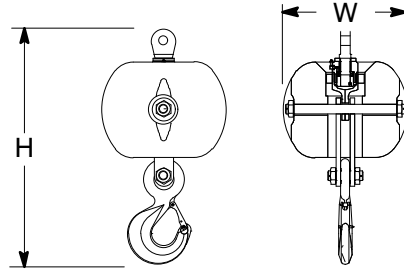

15 Ton (13.6mt) Non-Swivel Hook Ball* ①

Width	21.65 in	(0.55m)
Height	40.36 in	(1.03m)
Weight	1,192 lb	(541kg)

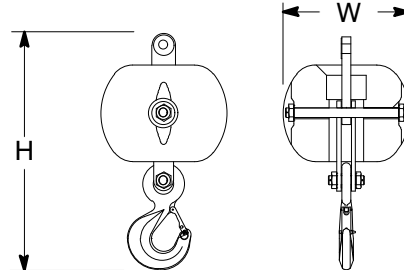

Hook Blocks

30 Ton (27.2mt) 1-Sheave Hook Block* ①

Width1	21.13 in	(0.54m)
Width2	28.75 in	(0.73m)
Width3	13.34 in	(0.34m)
Height	53.92 in	(1.37m)
Weight	1,706 lb	(774kg)

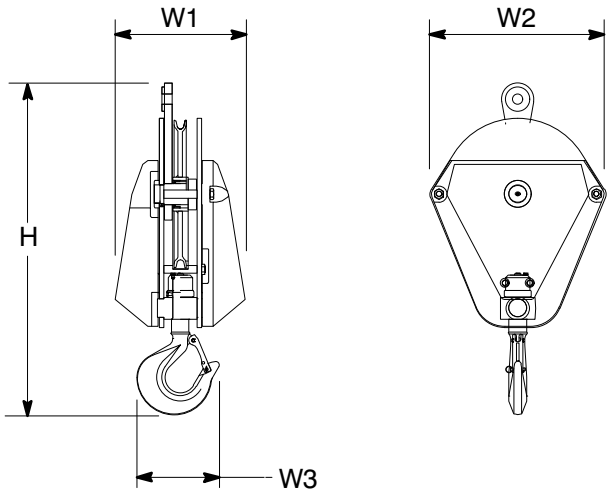

40 Ton (36.3mt) 1-Sheave Hook Block* ①

Width1	25.50 in	(0.65m)
Width2	28.75 in	(0.73m)
Width3	15 in	(0.38m)
Height	60.75 in	(1.54m)
Weight	2,293 lb	(1 040kg)

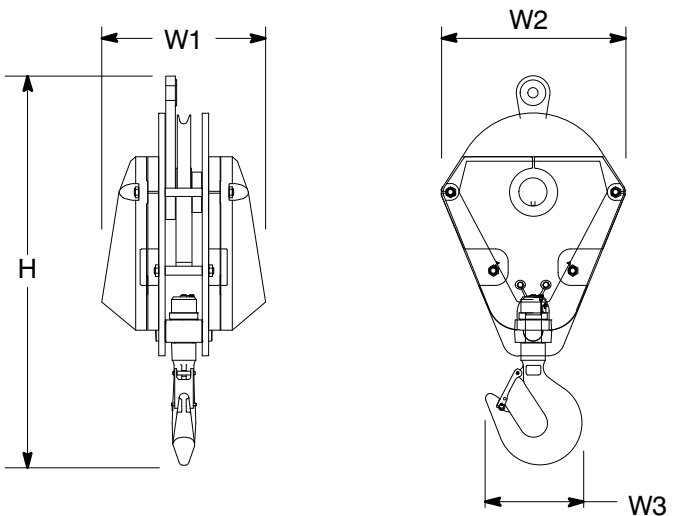

Number inside black circle “①” = # of components
 * – Optional equipment

60 Ton (54.4mt)

2–Sheave Hook Block* ①

Width1	15.50 in	(0.39m)
Width2	28.75 in	(0.73m)
Width3	18.75 in	(0.48m)
Height	67.00 in	(1.70m)
Weight	1,650 lb	(747kg)

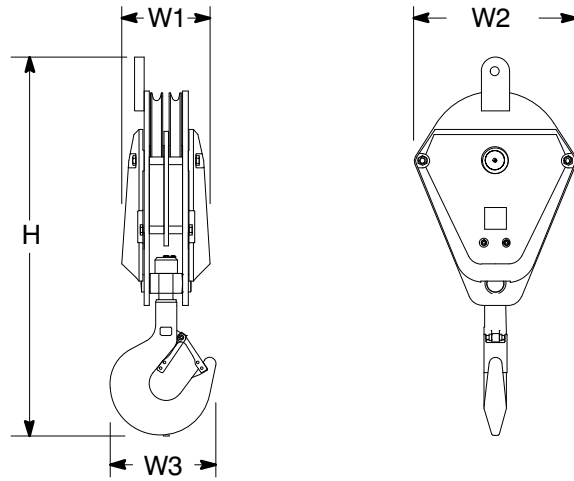

80 Ton (72.6mt)

3-Sheave Hook Block* ①

Width1	18.89 in	(0.48m)
Width2	28.75 in	(0.73m)
Width3	20.31 in	(0.52m)
Height	69.74 in	(1.77m)
Weight	2,085 lb	(946kg)

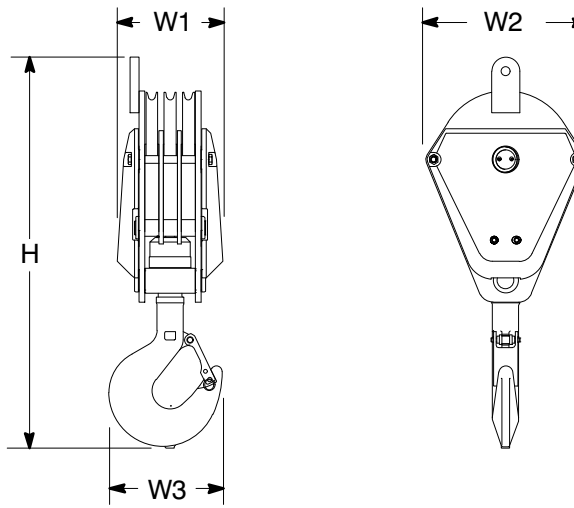

110 Ton (100.0mt)

4–Sheave Hook Block* ①

Width1	28.00 in	(0.71m)
Width2	28.75 in	(0.73m)
Width3	23.00 in	(0.58m)
Height	65.50 in	(1.66m)
Weight	3,000 lb	(1 361kg)

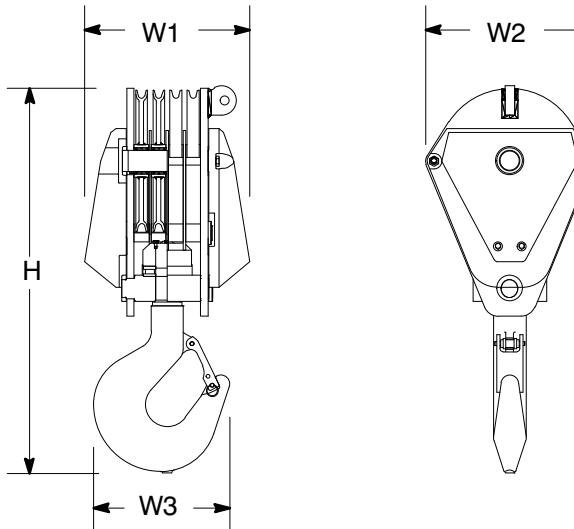

Number inside black circle “①” = # of components

* – Optional equipment

150 Ton (136.1mt)
5-Sheave Hook Block* ①

Width1	23.90 in	(0.61m)
Width2	28.75 in	(0.73m)
Width3	28.12 in	(0.71m)
Height	80.81 in	(2.05m)
Weight	3,606 lb	(1 636kg)

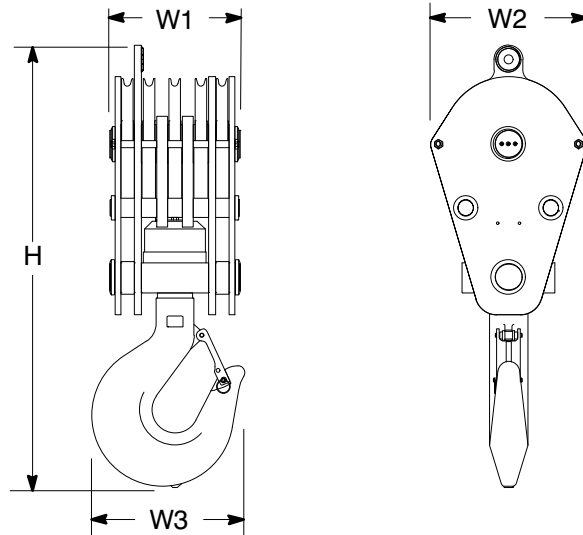

200 Ton (181.4mt)
6-Sheave Hook Block* ①

Width1	27 in	(0.69m)
Width2	35.25 in	(0.90m)
Width3	34.75 in	(0.88m)
Height	95.50 in	(2.43m)
Weight	3,860 lb	(1 751kg)

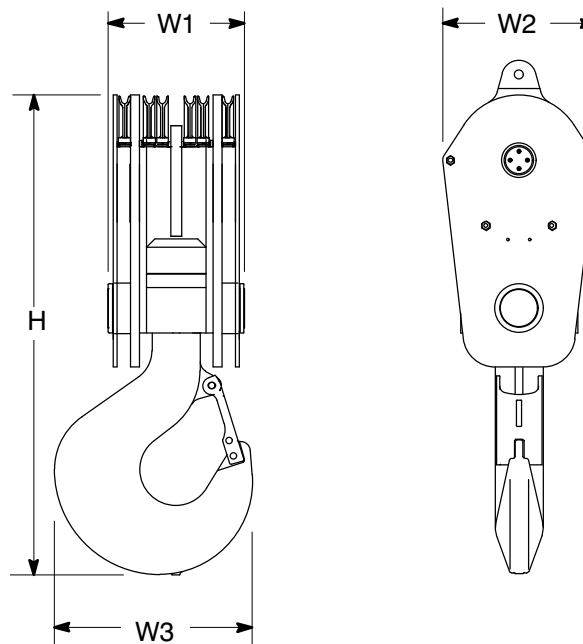

Number inside black circle “①” = # of components
 * – Optional equipment

Working Weights

Based on basic crane including Isuzu 6HK1–T4i diesel engine, turntable bearing, independent hydraulic powered drums, boom hoist limiting device, independent hydraulic swing and travel, full counterweight, swing brake, drum rotation indicators, hydraulic boom foot pin removal, and crawler lower with 44 in (1.12m) wide track shoes, sealed track rollers, catwalks, plus the following:	Ctwt “ABCDE” + “A”	
	lb (kg)	
Lifting crane – includes 55 ft (16.76m) basic tubular boom, 27 ft (8.23m) live mast, 1,185 ft (361.19m) of 26mm diameter wire rope, 660 ft (201.17m) of 7/8 in (22mm) diameter boom hoist rope, 200 Ton (181.44mt) hook block, and basic pendants.	270,130 (122 529)	
Ground Bearing Pressure	psi	10.73
	kg/cm ²	0.75

Transport Weights

Base Crane: Rigid boom backstops, 50 gal (189L) of fuel, catwalks (both sides), 27 ft (8.23m) live mast, bail, boom hoist rope, boom base section, 1,185 ft (361.19m) of type "ZB" front hoist rope, and 1,185 ft (361.19m) of type "ZB" rear hoist rope.

Item Description	Gross Weight		Transport Loads								
	lb	(kg)	#1	#2	#3	#4	#5	#6	#7	#8	#9
Base Crane	88,305	40 055	1								
Add Side Frame – Two Required 44"	41,400	18 779		1	1						
Add "A" Base Counterweight w/ Self Assy Cylinder	20,320	9 217						1			
Add "B" Wing Counterweight – Right Side	14,200	6 410								1	
Add "B" Wing Counterweight – Left Side	15,000	6 780							1		
Add "C" Wing Counterweight – Right Side	14,200	6 410				1					
Add "C" Wing Counterweight – Left Side	15,000	6 780				1					
Add "D" Wing Counterweight – Right Side	14,200	6 410								1	
Add "D" Wing Counterweight – Left Side	15,000	6 780							1		
Add "E" Wing Counterweight – Right Side	14,200	6 410									1
Add "E" Wing Counterweight – Left Side	15,000	6 780						1			
Add "A" Lower Counterweight – Two Required	17,650	8 000					2				
Add Hydraulic Third Drum without Rope	2,272	1 031									
Add 30 ft (9.14m) Boom Top Section	4,585	2 080								1	
Add 10 ft (3.05m) Extension(JE2) w/Pins and Pendants	1,439	653					1				
Add 20 ft (6.10m) Extension(JE2) w/Pins and Pendants	2,382	1 080			1						
Add 30 ft (9.14m) Extension(JE2) w/Pins and Pendants	3,341	1 515							1		
Add 40 ft (12.19m) Extension(JE2) w/Pins and Pendants	4,339	1 968				1	1				
Add 20 ft (6.10m) Extension(FE) w/Pins and Pendants	1,961	890							1		
Add 30 ft (9.14m) Extension(FE) w/Pins and Pendants	2,681	1 216						1			
Add 40 ft (12.19m) Extension(FE) w/Pins and Pendants	3,457	1 568									1
Add 10 ft (3.05m) Extension(FE) w/Pins and Pendants	1,221	554									
Add 30 ft (9.14m) Basic Jib	2,328	1 056		1							
Add 10 ft (3.05m) Jib Extension w/Pins and Pendants	588	267							1		
Add 20 ft (6.10m) Jib Extension w/Pins and Pendants	1,031	468				3					
Add 5 ft (1.52m) Auxiliary Tip Extension	671	304									
Add 15 Ton (13.6mt) Hook Ball (Non–Swivel)	1,200	544							1		
Add 15 Ton (13.6mt) Hook Ball (Swivel)	1,215	551									
Add 200 Ton (158.8mt) Six sheave Hook Block	4,125	1 871								1	
25 ft (7.62m) Boom Base Section	5,303	2 405									
Main Hoist Rope	1,215	551									
Rear Drum Auxiliary Wire Rope	2,406	1 091									
50 gal (189L) of Fuel	362	164									
Approximate Total Shipping Weight	lb		88,305	43,728	43,782	36,632	41,078	38,001	37,090	37,110	17,657
	kg		40 055	19 835	19 860	16 616	18 633	17 237	16 824	16 833	8 009

Notes:

Estimated weights vary by +/- 2%. Numbers in the load columns (numbers 1 – 10) represent quantities.

Estimated transport loads assume the load out consist of 285 ft (86.87m) of boom and 100 ft (30.48m) of jib and full counterweight.

Support loads were targeted at 45,000 lb (20 412kg), 8.5 ft (2.59m) wide, and 48 ft (14.63m) long trailer. This may vary depending on state laws, empty truck/trailer weights, and style of trailer.

Transport Drawings

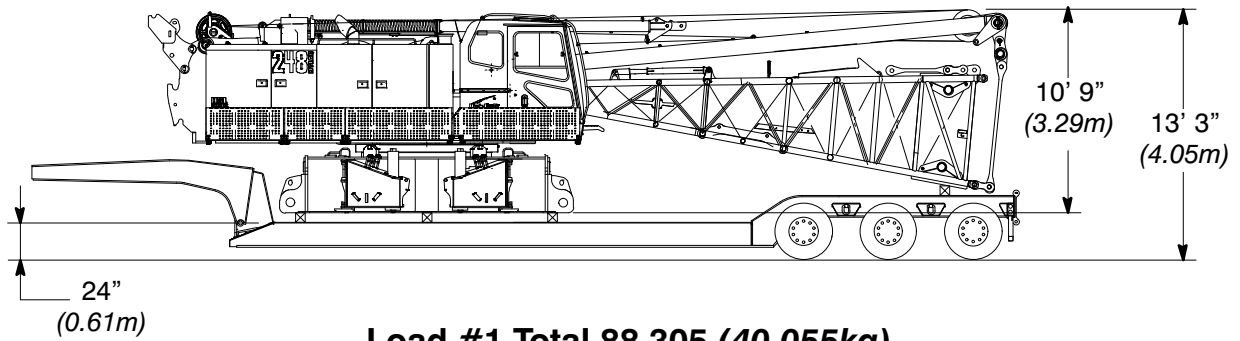

Load #1 Total 88,305 (40 055kg)
Base Crane

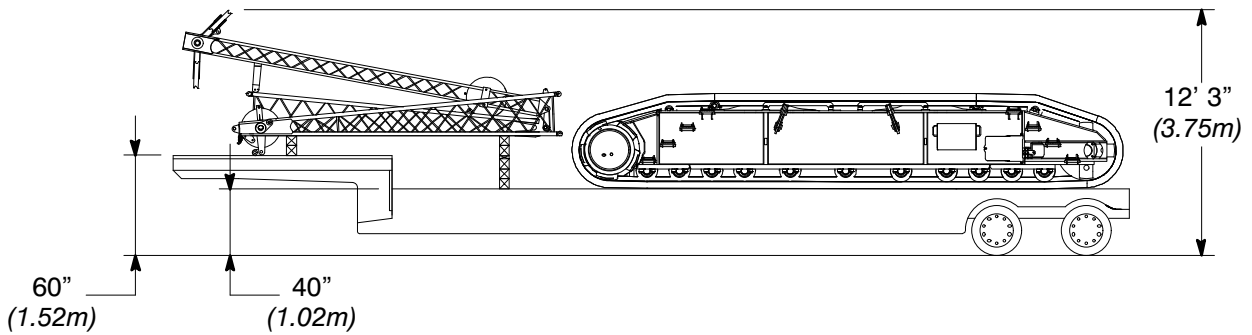

Load #2 Total 43,728 (19 835kg)
Side frame with 44 in (1.12m) track shoes and 30 ft (9.14m) basic fixed jib

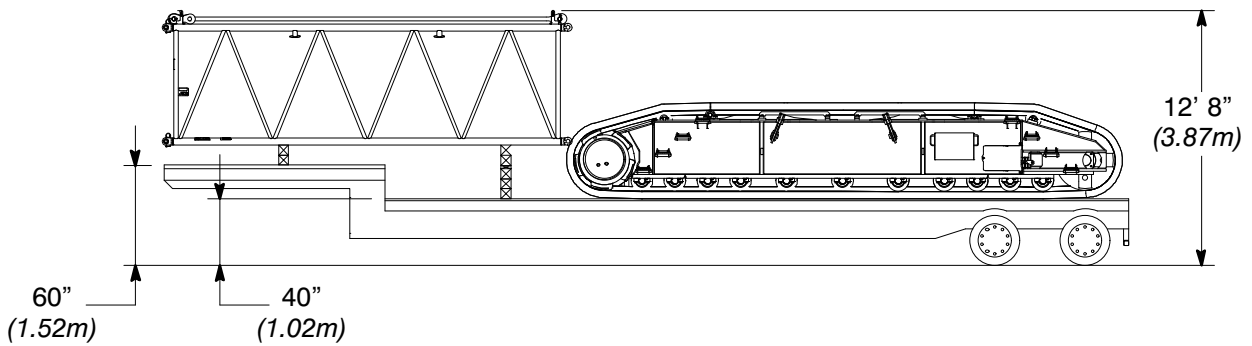

Load #3 Total 43,782 (19 860kg)
Side frame with 44 in (1.12m) track shoes and 20 ft (6.10m) JE2 extension

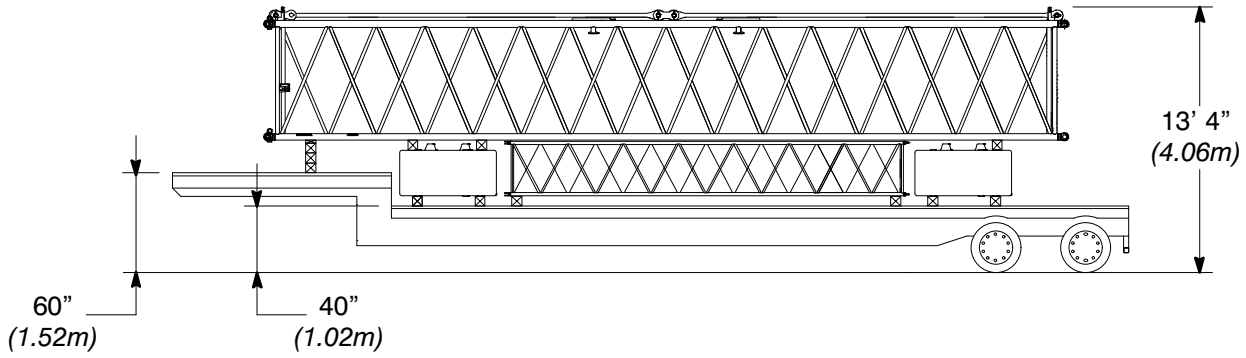

Load #4 Total 36,632 (16 616kg)

Right wing counterweight, left wing counterweight,
3 – 20 ft (6.10m) jib extensions, and 40 ft (12.19m) JE2 boom extension

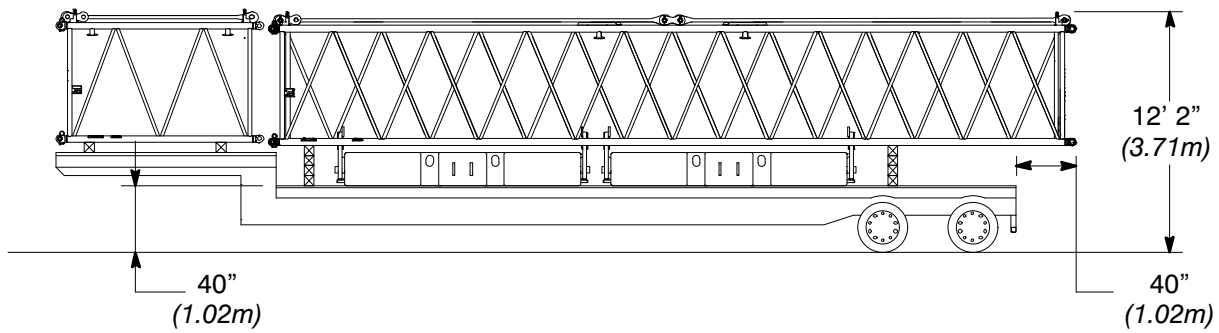

Load #5 Total 41,078 (18 633kg)

2 – "A" lower counterweights, 40 ft (12.19m) JE2 boom extension,
and 10 ft (3.05m) JE2 boom extension

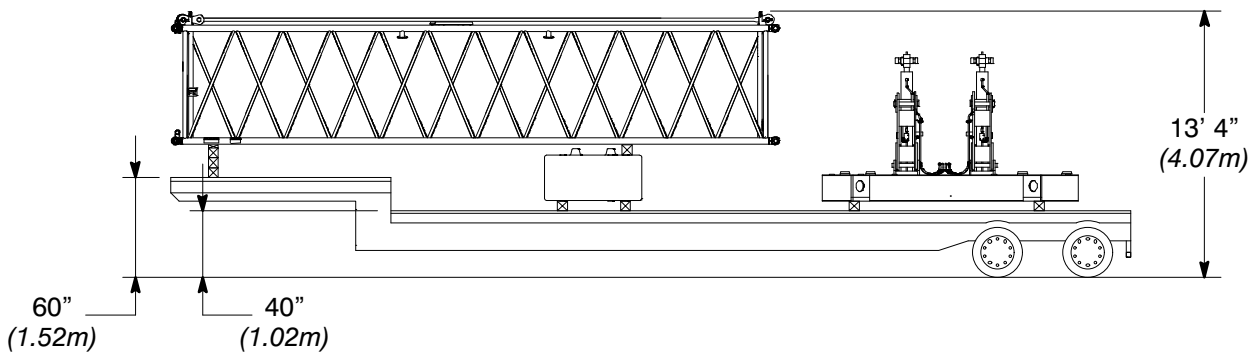

Load #6 Total 38,001 (17 237kg)

Base counterweight and cylinders, left wing counterweight,
and 30 ft (4.57m) FE boom extension

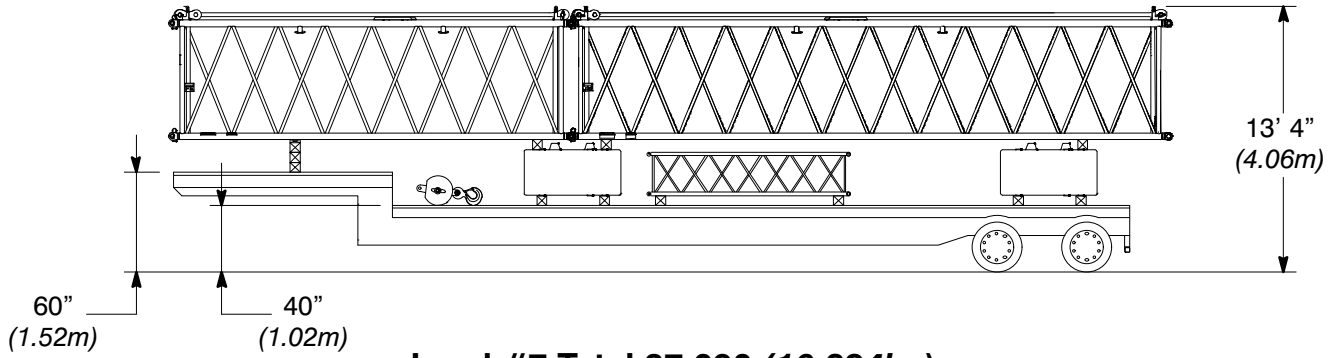

Load #7 Total 37,090 (16 824kg)

2 – Left wing counterweights, 20 ft (6.10m) FE boom extension, 30 ft (9.14m) JE2 boom extension, 10 ft (3.05m) fixed jib extension, and 15 Ton (13.6mt) hook ball

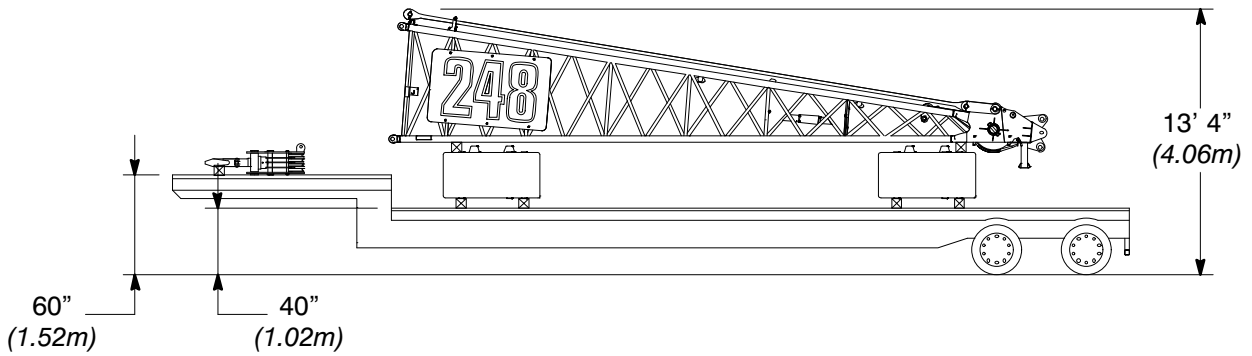

Load #8 Total 37,110 (16 833kg)

2 – Right wing counterweights, 30 ft (9.14m) boom top section, and 200 Ton (158.8mt) 6-sheave hook block

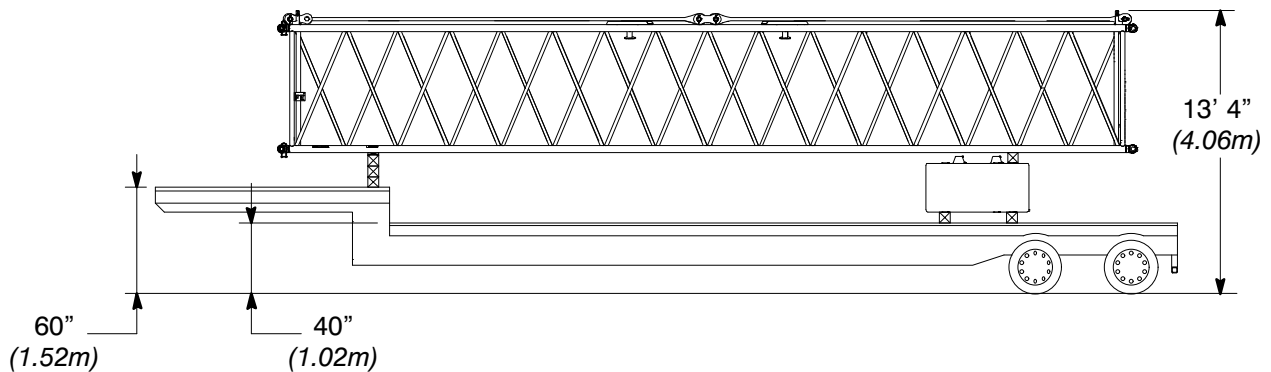

Load #9 Total 17,657 (8 009kg)

40 ft (12.19m) FE boom extension and right wing counterweight

Load Hoist Performance

Front And Rear Drum – 26mm Wire Rope

Rope Layer	Maximum Line Pull		No Load Line Speed		Full Load Line Speed		Pitch Diameter		Layer		Total	
	lb	kg	ft/min	m/min	ft/min	m/min	in	mm	ft	m	ft	m
1	46,924	21,285	364	111	136	41	22.8	580	137.5	41.9	137.5	41.9
2	43,597	19,776	391	119	137	42	24.9	632	148.0	45.1	285.5	87.0
3	40,711	18,466	419	128	138	42	26.9	684	158.5	48.3	444.0	135.3
4	38,183	17,320	447	136	135	41	29.0	736	169.0	51.5	612.9	186.8
5	35,951	16,307	475	145	107	33	31.0	788	179.5	54.7	792.4	241.5
6	33,965	15,406	502	153	58	18	33.1	840	190.0	57.9	982.4	299.4

Boom Hoist Drum – 7/8 in (22mm) Wire Rope

Rope Layer	Maximum Line Pull		No Load Line Speed		Pitch Diameter		Layer		Total	
	lb	kg	ft/min	m/min	in	mm	ft	m	ft	m
1	46,922	21,284	142	43	21.8	553	68.4	20.8	68.4	20.8
2	43,896	19,911	152	46	23.5	598	73.1	22.3	141.5	43.1
3	41,236	18,704	162	49	25.3	643	77.8	23.7	219.3	66.9
4	38,880	17,636	171	52	27.1	687	82.5	25.2	301.9	92.0
5	36,779	16,683	181	55	28.8	732	87.3	26.6	389.1	118.6
6	34,893	15,827	191	58	30.6	777	92.0	28.0	481.1	146.6
7	33,191	15,055	201	61	32.4	822	96.7	29.5	577.8	176.1

Third Drum – 1 in (25mm) Wire Rope

Rope Layer	Maximum Line Pull		No Load Line Speed		Full Load Line Speed		Pitch Diameter		Layer		Total	
	lb	kg	ft/min	m/min	ft/min	m/min	in	mm	ft	m	ft	m
1	24,754	11 228	325	99.2	184	56.1	19.7	500	150	45.8	150	45.8
2	22,473	10 194	358	109.2	203	61.8	21.7	551	165	50.4	316	96.2
3	20,576	9 333	391	119.3	221	67.5	23.7	602	181	55.1	496	151.2
4	18,975	8 607	424	129.4	240	73.1	25.7	653	196	59.7	692	210.9
5	17,605	7 986	457	139.4	259	78.8	27.7	704	211	64.3	903	275.3

Wire Rope Application	Diameter		Type	Max. Permissible Load		Wire Rope Descriptions
	in	mm		lb	kg	
Boom Hoist	7/8	22	FC	28,500	12 927	6 Strand, Compacted Strand, Swaged, Preformed, I.W.R.C., Right Lay, Regular Lay
Front Hoist	1.02	26	ZB	29,200	13 245	34 X 7 Rotation Resistant – Extra Improved Plow Steel – Right Regular Lay or Right Lang Lay
Third Drum (Optional)	1	25	RB	22,760	10 324	19 X 19 Rotation Resistant Compacted Strand – High Strength – Preformed, Right Regular Lay
Rear Drum	1.02	26	ZB	29,200	13 245	34 X 7 Rotation Resistant – Extra Improved Plow Steel – Right Regular Lay or Right Lang Lay

Working Areas

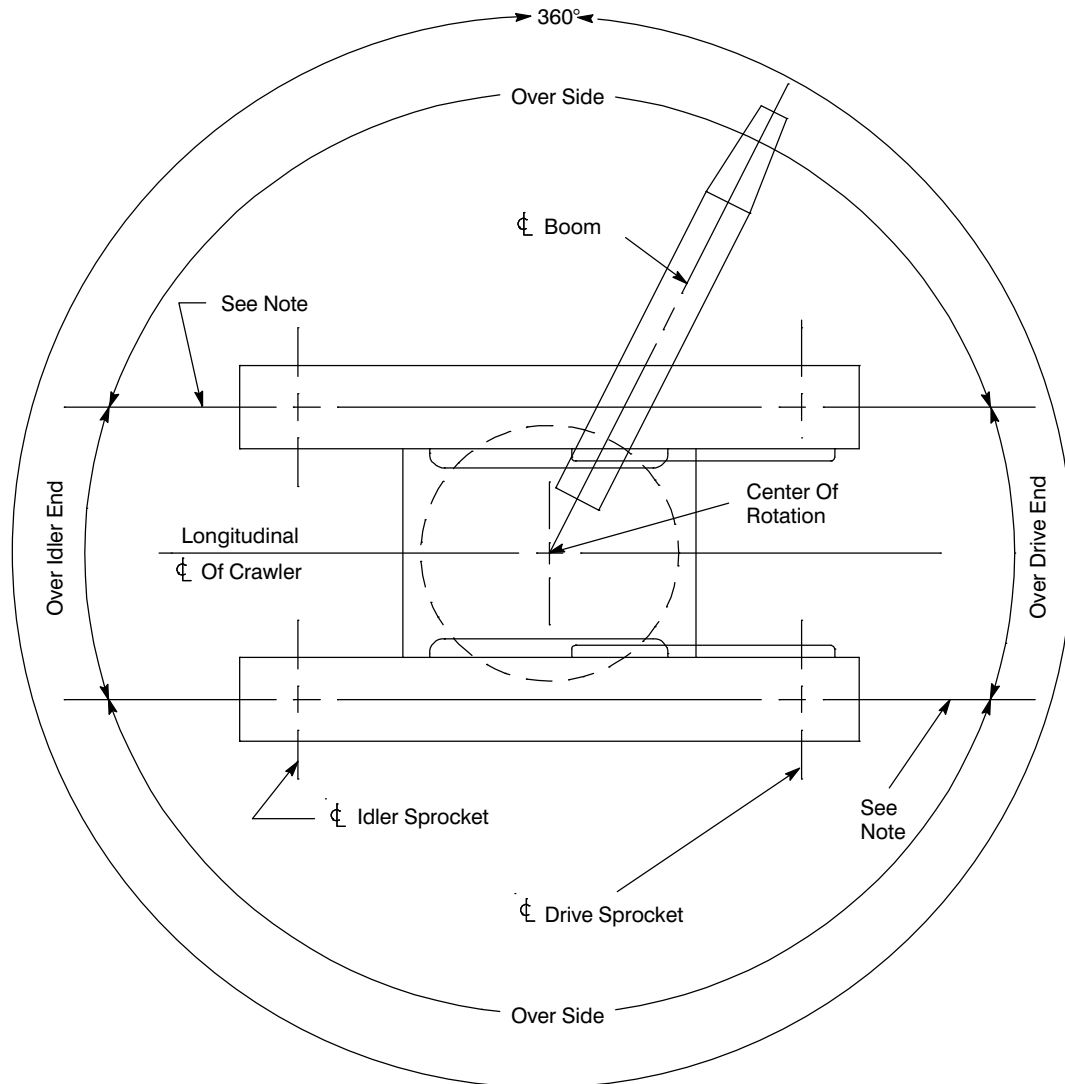

Note: These Lines Determine The Limiting Position Of Any Load For Operation Within Working Areas Indicated.

Attachments

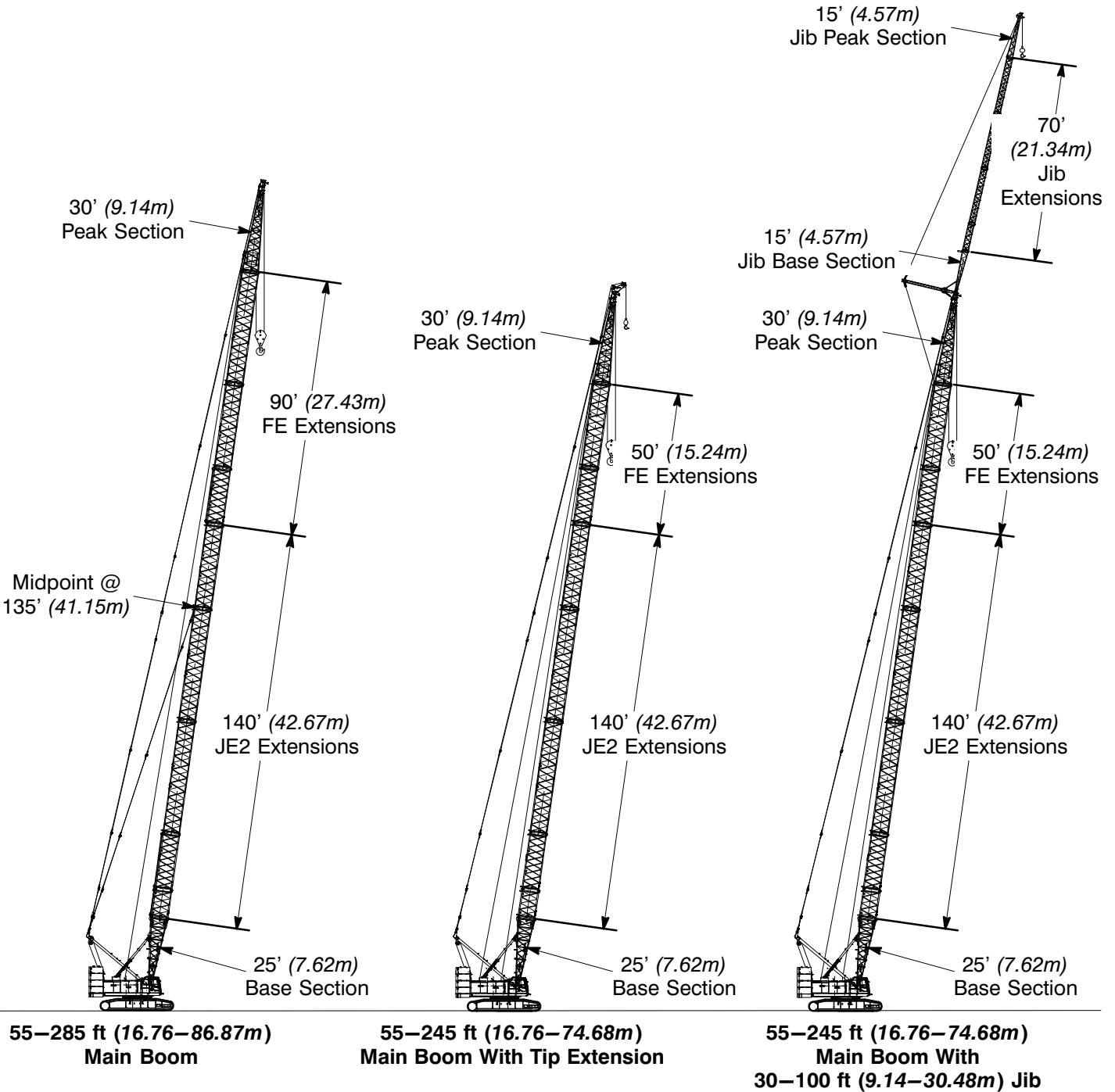

Main Boom Make-up

Boom Length		Base	"JE2" Heavy Wall Boom Extensions					"FE" Light Wall Boom Extensions				Top
ft	m	25 (7.62)	10 (3.05)	20 (6.14)	30 (9.10)	40 (12.19)	10 (3.05)	20 (6.14)	30 (9.10)	40 (12.19)	30 (9.10)	
55	16.76	1									1	
65	19.81	1	1								1	
75	22.86	1		1							1	
85	25.91	1			1						1	
95	28.96	1				1					1	
105	32.00	1	1			1					1	
115	35.05	1		1		1					1	
125	38.10	1				1	1				1	
135	41.15	1					2				1	
145	44.20	1	1				2				1	
155	47.24	1		1			2				1	
165	50.29	1				1	2				1	
175	53.34	1	1			1	2				1	
185	56.39	1		1		1	2				1	
195	59.44	1	1	1		1	2				1	
205	62.48	1	1	1		1	2	1			1	
215	65.53	1	1	1		1	2		1		1	
225	68.58	1	1	1		1	2			1	1	
235	71.63	1	1	1		1	2			1	1	
245	74.68	1	1	1		1	2		1	1	1	
255	77.72	1	1	1		1	2		1		1	
265	80.77	1	1	1		1	2			1	1	
275	83.82	1	1	1		1	2	1		1	1	
285	86.87	1	1	1		1	2		1	1	1	

Notes:

- Capacities shown are in kips/metric tons (1 kip = 1,000 lb / 1 metric ton = 0.45 kips) and are not more than 75% of the tipping loads with the crane standing level on firm supporting surface. A deduction must be made from these capacities for weight of hook block, hook ball, sling, grapple, load weighing device, etc. When using main hook while jib or tip extension is attached, reduce capacities by values shown in Crane Rating Manual. See Operator's Manual for all limitations when raising or lowering attachment.
- The capacities in the shaded areas are based on structural strength. The capacities in the non-shaded areas are based on stability ratings.
- For recommended reeving, parts of line, wire rope type, and wire rope inspection, see Wire Rope Capacity Chart, Operator's Manual, and Parts Manual.
- Load ratings are based on freely suspended loads and make no allowances for such factors as the effect of the wind, ground conditions, and operating speeds. The operator shall therefore reduce load ratings in order to take these conditions into account. Refer to the Crane Rating Manual for Wind Speed Restrictions.
- The 27 ft (8.23m) live mast must be used for all capacities listed.
- The least stable rated condition is over the side.
- Booms must be erected and lowered over the end for maximum stability.
- Main boom length must not exceed 285 ft (86.87m).
- Do not operate at radii and boom lengths where the Crane Rating Manual lists no capacity. Do not use longer booms or jibs than those listed in the Crane Rating Manual. Any of the above can cause a tipping condition, or boom and jib failure.
- These capacities are in compliance with ASME/ANSI B30.5 at date of manufacture.
- These capacities apply only to the crane as originally manufactured and normally equipped by Link-Belt Construction Equipment Company.
- The first 165' (50.29m) of boom must be "JE2" heavy wall sections.

Main Boom Working Range Diagram

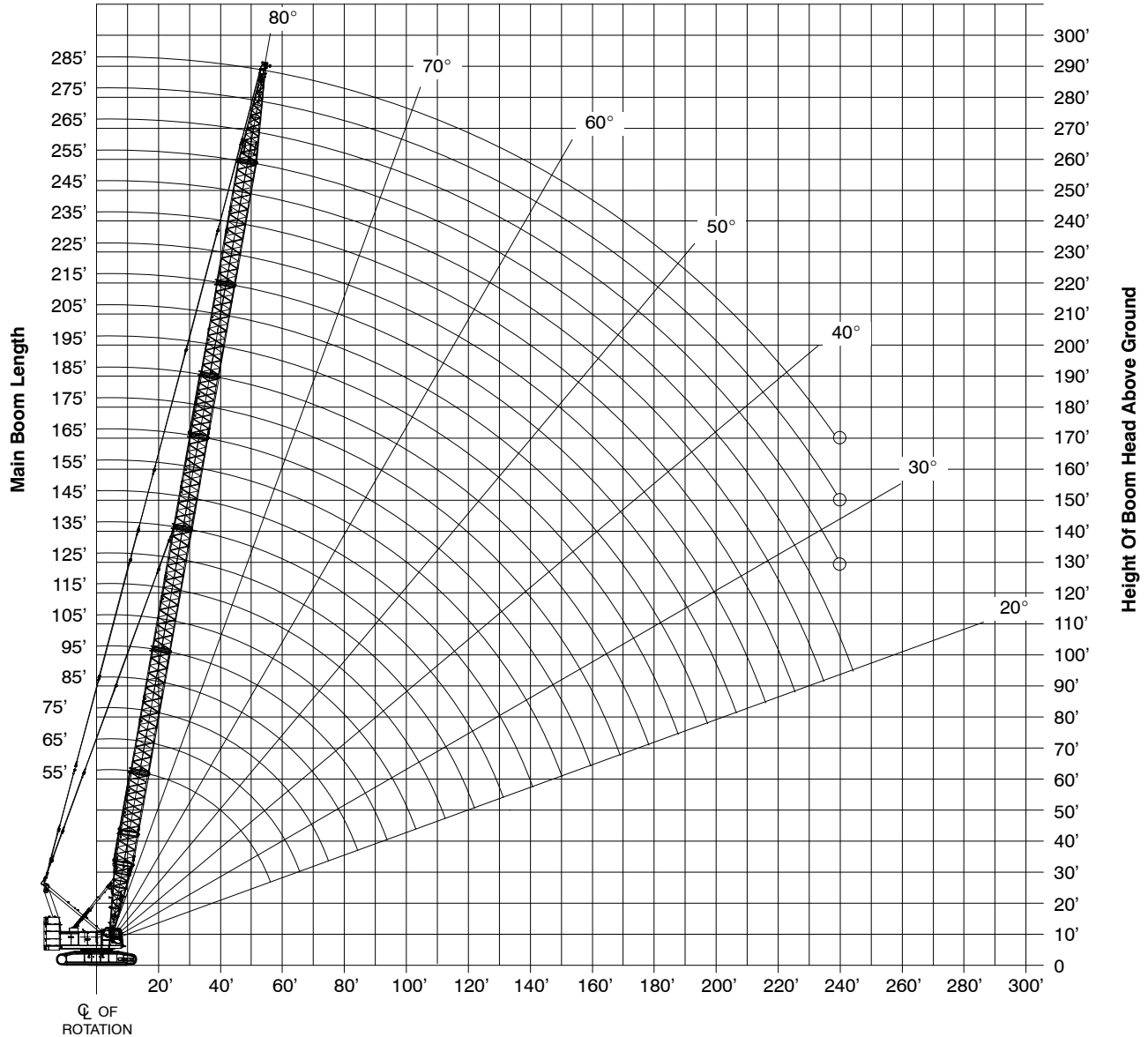

Notes:

Operating Radius From Centerline Of Rotation

1. Boom geometry shown is for unloaded condition and crane standing level on firm supporting surface. Boom deflection, subsequent radius, and boom angle change must be accounted for when applying load to hook.
2. Maximum and minimum boom angles are equal to the values listed in the capacity charts for each boom length.

Main Boom Load Charts

Main Boom Lift Capacity Chart – 360° Rotation ABCDE+A Counterweight [All capacities are listed in kips (mt)]													
Load Radius ft (m)	Boom Length - ft (m)												Load Radius ft (m)
	55 (16.8)	65 (19.8)	75 (22.9)	85 (25.9)	95 (29.0)	105 (32.0)	115 (35.1)	125 (38.1)	135 (41.1)	145 (44.2)	155 (47.2)	165 (50.3)	
12 (3.7)	400.0 (181.4)												12 (3.7)
15 (4.6)	333.6 (151.3)												15 (4.6)
16 (4.9)	314.4 (142.6)	313.3 (142.1)											16 (4.9)
17 (5.2)	297.1 (134.8)	296.1 (134.3)											17 (5.2)
18 (5.5)	281.7 (127.8)	280.8 (127.4)	279.7 (126.9)										18 (5.5)
19 (5.8)	267.6 (121.4)	266.8 (121.0)	265.8 (120.6)										19 (5.8)
20 (6.1)	255.0 (115.7)	254.3 (115.3)	253.4 (114.9)	252.8 (114.7)									20 (6.1)
25 (7.6)	205.8 (93.3)	205.3 (93.1)	204.6 (92.8)	204.2 (92.6)	203.4 (92.3)	202.5 (91.9)	201.8 (91.5)						25 (7.6)
30 (9.1)	172.3 (78.2)	171.9 (78.0)	171.4 (77.7)	171.1 (77.6)	170.4 (77.3)	169.7 (77.0)	169.0 (76.7)	168.2 (76.3)	167.4 (75.9)	166.6 (75.6)			30 (9.1)
35 (10.7)	147.2 (66.8)	145.1 (65.8)	143.4 (65.0)	146.7 (66.5)	146.1 (66.3)	145.4 (66.0)	144.8 (65.7)	144.3 (65.5)	144.0 (65.3)	142.8 (64.8)	141.7 (64.3)	140.7 (63.8)	35 (10.7)
40 (12.2)	125.1 (56.7)	123.2 (55.9)	121.3 (55.0)	127.3 (57.7)	126.0 (57.2)	124.8 (56.6)	123.6 (56.1)	122.5 (55.6)	121.4 (55.1)	120.3 (54.6)	119.3 (54.1)	118.4 (53.7)	40 (12.2)
50 (15.2)	94.6 (42.9)	93.7 (42.5)	92.5 (42.0)	94.9 (43.0)	94.7 (43.0)	94.3 (42.8)	94.0 (42.6)	93.4 (42.4)	92.4 (41.9)	91.5 (41.5)	90.6 (41.1)	89.7 (40.7)	50 (15.2)
60 (18.3)		31.3 (33.8)	74.1 (33.6)	74.8 (33.9)	74.6 (33.8)	74.3 (33.7)	73.9 (33.5)	73.6 (33.4)	73.2 (33.2)	72.8 (33.0)	72.4 (32.8)	71.7 (32.5)	60 (18.3)
70 (21.3)			60.4 (27.4)	61.3 (27.8)	61.0 (27.7)	60.7 (27.5)	60.4 (27.4)	60.0 (27.2)	59.6 (27.0)	59.2 (26.9)	58.8 (26.7)	58.4 (26.5)	70 (21.3)
80 (24.4)				51.7 (23.5)	51.5 (23.4)	51.2 (23.2)	50.9 (23.1)	50.5 (22.9)	50.1 (22.7)	49.8 (22.6)	49.4 (22.4)	49.0 (22.2)	80 (24.4)
90 (27.4)					44.2 (20.0)	43.9 (19.9)	43.6 (19.8)	43.2 (19.6)	42.9 (19.5)	42.5 (19.3)	42.1 (19.1)	41.7 (18.9)	90 (27.4)
100 (30.5)						38.2 (17.3)	37.9 (17.2)	37.6 (17.1)	37.2 (16.9)	36.8 (16.7)	36.4 (16.5)	36.0 (16.3)	100 (30.5)
110 (33.5)							33.4 (15.1)	33.0 (15.0)	32.6 (14.8)	32.2 (14.6)	31.8 (14.4)	31.4 (14.2)	110 (33.5)
120 (36.6)								29.3 (13.3)	28.9 (13.1)	28.7 (13.0)	28.4 (12.9)	28.0 (12.7)	120 (36.6)
130 (39.6)									26.0 (11.8)	25.6 (11.6)	25.2 (11.4)	24.9 (11.3)	130 (39.6)
140 (42.7)										23.0 (10.4)	22.6 (10.3)	22.1 (10.0)	140 (42.7)
150 (45.7)											23.0 (10.4)	19.9 (9.0)	150 (45.7)

This material is supplied for reference use only. Operator must refer to in-cab Crane Rating Manual and Operator’s Manual to determine allowable crane lifting capacities and assembly and operating procedures.

Main Boom Lift Capacity Chart – 360° Rotation ABCDE+A Counterweight [All capacities are listed in kips (mt)]													
Load Radius ft (m)	Boom Length - ft (m)												Load Radius ft (m)
	175 (53.3)	185 (56.4)	195 (59.4)	205 (62.5)	215 (65.5)	225 (68.6)	235 (71.6)	245 (74.7)	255 (77.7)	265 (80.8)	275 (83.8)	285 (86.9)	
35 (10.7)	139.7 (63.4)												35 (10.7)
40 (12.2)	117.4 (53.3)	116.5 (52.8)	115.5 (52.4)										40 (12.2)
50 (15.2)	88.8 (40.3)	88.0 (39.9)	87.1 (39.5)	86.5 (39.2)	85.8 (38.9)	86.1 (39.1)	81.1 (36.8)	74.7 (33.9)	71.1 (32.3)				50 (15.2)
60 (18.3)	70.9 (32.2)	70.1 (31.8)	69.3 (31.4)	68.7 (31.2)	68.1 (30.9)	67.8 (30.8)	67.4 (30.6)	59.4 (26.9)	61.8 (28.0)	59.7 (27.1)	54.5 (24.7)	49.6 (22.5)	60 (18.3)
70 (21.3)	57.7 (26.2)	57.6 (26.1)	57.4 (26.0)	56.9 (25.8)	56.3 (25.5)	56.0 (25.4)	55.6 (25.2)	53.9 (24.4)	52.3 (23.7)	50.9 (23.1)	49.2 (22.3)	44.9 (20.4)	70 (21.3)
80 (24.4)	48.6 (22.0)	48.2 (21.9)	47.6 (21.6)	47.0 (21.3)	46.5 (21.1)	46.2 (21.0)	45.8 (20.8)	46.2 (21.0)	45.4 (20.6)	44.2 (20.0)	42.9 (19.5)	40.3 (18.3)	80 (24.4)
90 (27.4)	41.2 (18.7)	40.8 (18.5)	40.1 (18.2)	39.6 (18.0)	39.0 (17.7)	38.8 (17.6)	38.4 (17.4)	38.8 (17.6)	38.5 (17.5)	38.2 (17.3)	37.4 (17.0)	36.1 (16.4)	90 (27.4)
100 (30.5)	35.6 (16.1)	34.9 (15.8)	34.2 (15.5)	33.7 (15.3)	33.2 (15.1)	32.9 (14.9)	32.6 (14.8)	33.1 (15.0)	32.7 (14.8)	32.4 (14.7)	32.1 (14.6)	31.6 (14.3)	100 (30.5)
110 (33.5)	30.9 (14.0)	30.2 (13.7)	29.5 (13.4)	29.0 (13.2)	28.5 (12.9)	28.7 (13.0)	28.7 (13.0)	28.4 (12.9)	28.1 (12.7)	28.3 (12.8)	27.2 (12.3)	26.4 (12.0)	110 (33.5)
120 (36.6)	27.6 (12.5)	27.2 (12.3)	26.6 (12.1)	26.1 (11.8)	25.7 (11.7)	25.4 (11.5)	25.1 (11.4)	25.2 (11.4)	24.9 (11.3)	24.5 (11.1)	23.8 (10.8)	23.2 (10.5)	120 (36.6)
130 (39.6)	24.5 (11.1)	23.8 (10.8)	23.2 (10.5)	22.7 (10.3)	22.3 (10.1)	22.1 (10.0)	21.7 (9.8)	22.0 (10.0)	21.7 (9.8)	21.4 (9.7)	20.8 (9.4)	20.2 (9.2)	130 (39.6)
140 (42.7)	21.5 (9.8)	20.9 (9.5)	20.3 (9.2)	19.9 (9.0)	19.4 (8.8)	19.2 (8.7)	18.9 (8.6)	19.4 (8.8)	19.0 (8.6)	18.6 (8.4)	18.1 (8.2)	17.7 (8.0)	140 (42.7)
150 (45.7)	19.0 (8.6)	18.4 (8.3)	17.8 (8.1)	17.4 (7.9)	16.9 (7.7)	16.7 (7.6)	16.4 (7.4)	17.1 (7.8)	16.6 (7.5)	16.3 (7.4)	15.8 (7.2)	15.4 (7.0)	150 (45.7)
160 (48.8)	16.8 (7.6)	16.2 (7.3)	15.7 (7.1)	15.2 (6.9)	14.8 (6.7)	14.6 (6.6)	14.3 (6.5)	14.9 (6.8)	14.3 (6.5)	14.1 (6.4)	13.7 (6.2)	13.3 (6.0)	160 (48.8)
170 (51.8)		14.3 (6.5)	13.7 (6.2)	13.3 (6.0)	12.9 (5.9)	12.7 (5.8)	12.4 (5.6)	12.9 (5.9)	12.4 (5.6)	12.1 (5.5)	11.7 (5.3)	11.5 (5.2)	170 (51.8)
180 (54.9)			12.0 (5.4)	11.7 (5.3)	11.3 (5.1)	11.1 (5.0)	10.8 (4.9)	11.1 (5.0)	8.9 (4.0)	10.4 (4.7)	10.1 (4.6)	9.8 (4.4)	180 (54.9)
190 (57.9)				10.2 (4.6)	9.8 (4.4)	9.6 (4.4)	9.3 (4.2)	9.5 (4.3)	7.6 (3.4)	8.8 (4.0)	8.5 (3.9)	8.3 (3.8)	190 (57.9)
200 (61.0)					8.4 (3.8)	8.2 (3.7)	8.0 (3.6)	7.9 (3.6)	6.2 (2.8)	7.2 (3.3)	7.1 (3.2)	6.9 (3.1)	200 (61.0)
210 (64.0)						7.0 (3.2)	6.8 (3.1)	6.6 (3.0)	5.0 (2.3)	5.9 (2.7)	5.9 (2.7)	5.7 (2.6)	210 (64.0)
220 (67.1)							5.7 (2.6)	5.3 (2.4)	3.8 (1.7)	4.7 (2.1)	4.7 (2.1)	4.6 (2.1)	220 (67.1)
230 (70.1)								4.2 (1.9)	2.8 (1.3)	3.6 (1.6)	3.6 (1.6)	3.5 (1.6)	230 (70.1)
240 (73.2)										2.7 (1.2)	2.7 (1.2)	2.6 (1.2)	240 (73.2)

This material is supplied for reference use only. Operator must refer to in-cab Crane Rating Manual and Operator's Manual to determine allowable crane lifting capacities and assembly and operating procedures.

Jib Attachment Working Range Diagram

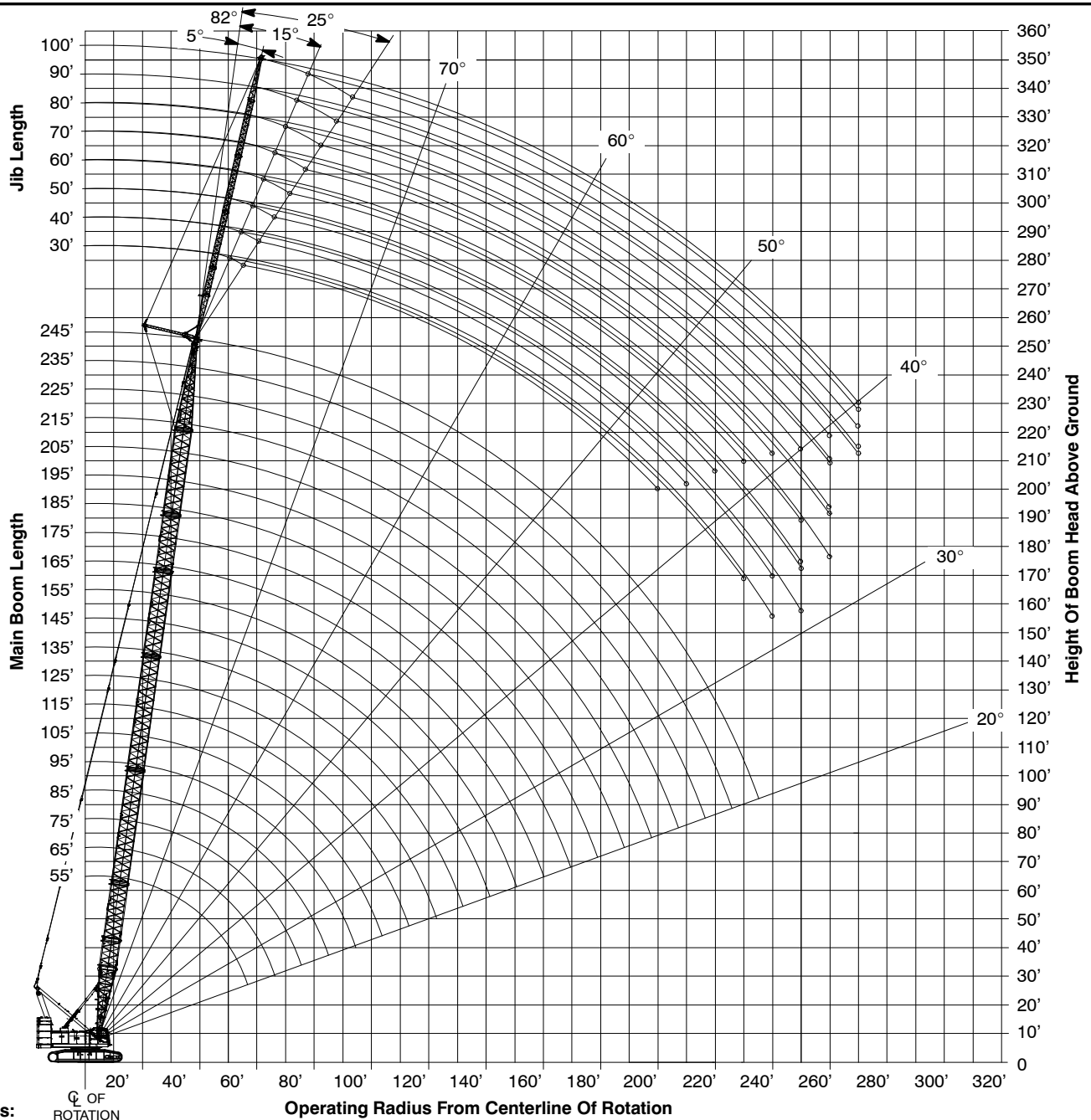

Notes:

Operating Radius From Centerline Of Rotation

1. Boom geometry shown is for unloaded condition and crane standing level on firm supporting surface. Boom deflection, subsequent radius, and boom angle change must be accounted for when applying load to hook.
2. Maximum and minimum boom angles are equal to the values listed in the capacity charts for each boom length.

Jib Attachment Load Charts

Tubular Main Boom + 30 ft (9.14m) Offset Tube Jib Length – 360° Rotation ABCDE+A [152,100 lb (68 991kg)] Counterweight [All capacities are listed in kips (mt)]																	
5 Degree Offset						15 Degree Offset					25 Degree Offset						
Load Radius ft (m)	Boom Length - ft (m)					Load Radius ft (m)	Boom Length - ft (m)					Load Radius ft (m)	Boom Length - ft (m)				
	55 (16.8)	95 (29.0)	145 (44.2)	195 (59.4)	245 (74.5)		55 (16.8)	95 (29.0)	145 (44.2)	195 (59.4)	245 (74.5)		55 (16.8)	95 (29.0)	145 (44.2)	195 (59.4)	245 (74.5)
35 (10.7)	58.0 (26.3)					35 (10.7)	56.3 (25.5)					35 (10.7)	44.4 (20.1)				
40 (12.2)	57.6 (26.1)	57.8 (26.2)				40 (12.2)	52.2 (23.7)	56.4 (25.6)				40 (12.2)	40.8 (18.5)	46.2 (21.0)			
50 (15.2)	51.2 (23.2)	57.7 (26.2)	57.6 (26.1)			50 (15.2)	43.2 (19.6)	54.4 (24.7)	54.5 (24.7)			50 (15.2)	35.3 (16.0)	41.1 (18.6)	45.7 (20.7)		
60 (18.3)	42.1 (19.1)	55.8 (25.3)	56.4 (25.6)			60 (18.3)	37.0 (16.8)	47.3 (21.5)	53.4 (24.2)			60 (18.3)	31.3 (14.2)	37.1 (16.8)	42.0 (19.1)		
70 (21.3)	35.8 (16.2)	50.9 (23.1)	55.1 (25.0)	52.4 (23.8)		70 (21.3)	32.6 (14.8)	42.0 (19.1)	51.5 (23.4)	49.9 (22.6)		70 (21.3)	29.0 (13.2)	33.9 (15.4)	38.9 (17.6)	42.4 (19.2)	
80 (24.4)	31.3 (14.2)	44.4 (20.1)	46.1 (20.9)	44.3 (20.1)	34.6 (15.7)	80 (24.4)		37.9 (17.2)	46.6 (21.1)	44.9 (20.4)	33.4 (15.1)	80 (24.4)		31.4 (14.2)	36.3 (16.5)	39.8 (18.1)	31.4 (14.2)
90 (27.4)		39.4 (17.9)	39.3 (17.8)	37.4 (17.0)	33.5 (15.2)	90 (27.4)		34.6 (15.7)	39.7 (18.0)	37.9 (17.2)	32.3 (14.7)	90 (27.4)		29.4 (13.3)	34.1 (15.5)	37.7 (17.1)	30.4 (13.8)
100 (30.5)		35.4 (16.1)	34.0 (15.4)	32.0 (14.5)	30.0 (13.6)	100 (30.5)		32.0 (14.5)	34.3 (15.6)	32.5 (14.7)	30.6 (13.9)	100 (30.5)		29.0 (13.2)	32.2 (14.6)	32.9 (14.9)	29.4 (13.3)
110 (33.5)		31.5 (14.3)	29.7 (13.5)	28.1 (12.7)	26.1 (11.8)	110 (33.5)		29.9 (13.6)	30.0 (13.6)	28.5 (12.9)	26.7 (12.1)	110 (33.5)			30.2 (13.7)	28.4 (12.9)	27.0 (12.2)
120 (36.6)		28.2 (12.8)	26.5 (12.0)	24.6 (11.2)	22.6 (10.3)	120 (36.6)			26.7 (12.1)	24.9 (11.3)	23.1 (10.5)	120 (36.6)			26.9 (12.2)	25.2 (11.4)	23.5 (10.7)
130 (39.6)			23.5 (10.7)	21.6 (9.8)	19.7 (8.9)	130 (39.6)			23.7 (10.8)	21.9 (9.9)	20.1 (9.1)	130 (39.6)			23.9 (10.8)	22.2 (10.1)	20.4 (9.3)
140 (42.7)			21.1 (9.6)	19.1 (8.7)	17.2 (7.8)	140 (42.7)			21.2 (9.6)	19.4 (8.8)	17.5 (7.9)	140 (42.7)				19.6 (8.9)	17.8 (8.1)
150 (45.7)			18.9 (8.6)	17.0 (7.7)	15.0 (6.8)	150 (45.7)			19.1 (8.7)	17.3 (7.8)	15.4 (7.0)	150 (45.7)				17.4 (7.9)	15.6 (7.1)
160 (48.8)			17.1 (7.8)	15.2 (6.9)	13.0 (5.9)	160 (48.8)				15.4 (7.0)	13.3 (6.0)	160 (48.8)				15.5 (7.0)	13.7 (6.2)
170 (51.8)				13.6 (6.2)	11.1 (5.0)	170 (51.8)				13.7 (6.2)	11.4 (5.2)	170 (51.8)				13.9 (6.3)	11.7 (5.3)
180 (54.9)				12.1 (5.5)	9.4 (4.3)	180 (54.9)				12.3 (5.6)	9.7 (4.4)	180 (54.9)					10.0 (4.5)
190 (57.9)				10.8 (4.9)	7.9 (3.6)	190 (57.9)				11.0 (5.0)	8.2 (3.7)	190 (57.9)					8.5 (3.9)
200 (61.0)				9.5 (4.3)	6.6 (3.0)	200 (61.0)					6.9 (3.1)	200 (61.0)					7.1 (3.2)
210 (64.0)				7.8 (3.5)	5.4 (2.4)	210 (64.0)					5.7 (2.6)	210 (64.0)					
220 (67.1)					4.4 (2.0)	220 (67.1)					4.5 (2.0)	220 (67.1)					
230 (70.1)					3.4 (1.5)	230 (70.1)					3.5 (1.6)	230 (70.1)					
240 (73.2)					2.5 (1.1)	240 (73.2)						240 (73.2)					
250 (76.2)						250 (76.2)						250 (76.2)					

This material is supplied for reference use only. Operator must refer to in-cab Crane Rating Manual and Operator’s Manual to determine allowable crane lifting capacities and assembly and operating procedures.

Tubular Main Boom + 60 ft (18.3m) Offset Tube Jib Length – 360° Rotation ABCDE+A [152,100 lb (68 991kg)] Counterweight [All capacities are listed in kips (mt)]																	
5 Degree Offset						15 Degree Offset					25 Degree Offset						
Load Radius ft (m)	Boom Length - ft (m)					Load Radius ft (m)	Boom Length - ft (m)					Load Radius ft (m)	Boom Length - ft (m)				
	55 (16.8)	95 (29.0)	145 (44.2)	195 (59.4)	245 (74.5)		55 (16.8)	95 (29.0)	145 (44.2)	195 (59.4)	245 (74.5)		55 (16.8)	95 (29.0)	145 (44.2)	195 (59.4)	245 (74.5)
35 (10.7)	33.2 (15.1)					35 (10.7)					35 (10.7)						
40 (12.2)	32.2 (14.6)	33.0 (15.0)				40 (12.2)	28.4 (12.9)				40 (12.2)						
50 (15.2)	28.4 (12.9)	31.5 (14.3)	31.5 (14.3)			50 (15.2)	27.0 (12.2)	27.6 (12.5)			50 (15.2)	24.1 (10.9)					
60 (18.3)	27.0 (12.2)	28.3 (12.8)	28.7 (13.0)	27.8 (12.6)		60 (18.3)	25.6 (11.6)	26.7 (12.1)	26.8 (12.2)		60 (18.3)	21.0 (9.5)	23.4 (10.6)				
70 (21.3)	25.2 (11.4)	27.3 (12.4)	27.9 (12.7)	27.2 (12.3)	25.2 (11.4)	70 (21.3)	22.2 (10.1)	25.8 (11.7)	26.1 (11.8)	25.5 (11.6)	70 (21.3)	18.7 (8.5)	21.2 (9.6)	23.3 (10.6)			
80 (24.4)	21.8 (9.9)	26.4 (12.0)	27.1 (12.3)	26.6 (12.1)	24.7 (11.2)	80 (24.4)	19.6 (8.9)	23.9 (10.8)	25.5 (11.6)	25.0 (11.3)	23.2 (10.5)	80 (24.4)	16.9 (7.7)	19.4 (8.8)	21.6 (9.8)	23.2 (10.5)	
90 (27.4)	19.1 (8.7)	25.4 (11.5)	26.4 (12.0)	26.1 (11.8)	24.2 (11.0)	90 (27.4)	17.6 (8.0)	21.7 (9.8)	25.0 (11.3)	24.5 (11.1)	22.7 (10.3)	90 (27.4)	15.5 (7.0)	17.9 (8.1)	20.2 (9.2)	21.8 (9.9)	19.7 (8.9)
100 (30.5)	17.1 (7.8)	22.7 (10.3)	25.8 (11.7)	25.6 (11.6)	23.7 (10.8)	100 (30.5)	16.1 (7.3)	19.8 (9.0)	23.8 (10.8)	24.1 (10.9)	22.2 (10.1)	100 (30.5)	14.4 (6.5)	16.7 (7.6)	19.0 (8.6)	20.6 (9.3)	19.3 (8.8)
110 (33.5)	15.5 (7.0)	20.5 (9.3)	25.2 (11.4)	25.1 (11.4)	23.2 (10.5)	110 (33.5)		18.3 (8.3)	22.1 (10.0)	23.7 (10.8)	21.7 (9.8)	110 (33.5)		15.7 (7.1)	17.9 (8.1)	19.6 (8.9)	18.9 (8.6)
120 (36.6)		18.7 (8.5)	24.4 (11.1)	24.6 (11.2)	22.8 (10.3)	120 (36.6)		17.0 (7.7)	20.6 (9.3)	23.3 (10.6)	21.2 (9.6)	120 (36.6)		14.8 (6.7)	17.0 (7.7)	18.7 (8.5)	18.5 (8.4)
130 (39.6)		17.3 (7.8)	22.4 (10.2)	22.5 (10.2)	20.6 (9.3)	130 (39.6)		16.0 (7.3)	19.3 (8.8)	22.3 (10.1)	20.7 (9.4)	130 (39.6)			16.2 (7.3)	17.8 (8.1)	18.2 (8.3)
140 (42.7)		16.0 (7.3)	20.8 (9.4)	20.0 (9.1)	18.0 (8.2)	140 (42.7)		15.1 (6.8)	18.2 (8.3)	20.5 (9.3)	18.8 (8.5)	140 (42.7)			15.5 (7.0)	17.1 (7.8)	17.8 (8.1)
150 (45.7)			19.4 (8.8)	17.8 (8.1)	15.9 (7.2)	150 (45.7)			17.2 (7.8)	18.3 (8.3)	16.5 (7.5)	150 (45.7)			14.8 (6.7)	16.4 (7.4)	17.1 (7.8)
160 (48.8)			17.9 (8.1)	16.0 (7.3)	14.0 (6.4)	160 (48.8)			16.4 (7.4)	16.4 (7.4)	14.6 (6.6)	160 (48.8)			14.3 (6.5)	15.8 (7.2)	15.1 (6.8)
170 (51.8)			16.3 (7.4)	14.4 (6.5)	12.2 (5.5)	170 (51.8)			15.7 (7.1)	14.7 (6.7)	12.9 (5.9)	170 (51.8)				15.1 (6.8)	13.4 (6.1)
180 (54.9)			14.8 (6.7)	12.9 (5.9)	10.5 (4.8)	180 (54.9)			15.0 (6.8)	13.3 (6.0)	11.2 (5.1)	180 (54.9)				13.6 (6.2)	11.7 (5.3)
190 (57.9)			13.6 (6.2)	11.6 (5.3)	9.0 (4.1)	190 (57.9)				12.0 (5.4)	9.6 (4.4)	190 (57.9)				12.2 (5.5)	10.1 (4.6)
200 (61.0)				10.5 (4.8)	7.7 (3.5)	200 (61.0)				10.8 (4.9)	8.2 (3.7)	200 (61.0)				11.0 (5.0)	8.7 (3.9)
210 (64.0)				9.4 (4.3)	6.5 (2.9)	210 (64.0)				9.7 (4.4)	7.0 (3.2)	210 (64.0)					7.4 (3.4)
220 (67.1)				8.2 (3.7)	5.4 (2.4)	220 (67.1)				8.5 (3.9)	5.9 (2.7)	220 (67.1)					6.2 (2.8)
230 (70.1)				7.2 (3.3)	4.4 (2.0)	230 (70.1)					4.8 (2.2)	230 (70.1)					5.1 (2.3)
240 (73.2)					3.5 (1.6)	240 (73.2)					3.9 (1.8)	240 (73.2)					
250 (76.2)					2.7 (1.2)	250 (76.2)					3.0 (1.4)	250 (76.2)					

This material is supplied for reference use only. Operator must refer to in-cab Crane Rating Manual and Operator’s Manual to determine allowable crane lifting capacities and assembly and operating procedures.

**Tubular Main Boom + 100 ft (30.5m) Offset Tube Jib Length – 360° Rotation
ABCDE+A [152,100 lb (68 991kg)] Counterweight
[All capacities are listed in kips (mt)]**

5 Degree Offset						15 Degree Offset						25 Degree Offset					
Load Radius ft (m)	Boom Length - ft (m)					Load Radius ft (m)	Boom Length - ft (m)					Load Radius ft (m)	Boom Length - ft (m)				
	55 (16.8)	95 (29.0)	145 (44.2)	195 (59.4)	245 (74.5)		55 (16.8)	95 (29.0)	145 (44.2)	195 (59.4)	245 (74.5)		55 (16.8)	95 (29.0)	145 (44.2)	195 (59.4)	245 (74.5)
50 (15.2)	11.4 (5.2)	12.0 (5.4)				50 (15.2)						50 (15.2)					
60 (18.3)	10.4 (4.7)	11.2 (5.1)	11.7 (5.3)			60 (18.3)	9.5 (4.3)					60 (18.3)					
70 (21.3)	9.5 (4.3)	10.4 (4.7)	11.1 (5.0)	11.3 (5.1)		70 (21.3)	8.7 (3.9)	9.2 (4.2)				70 (21.3)					
80 (24.4)	8.7 (3.9)	9.7 (4.4)	10.4 (4.7)	10.8 (4.9)	10.9 (4.9)	80 (24.4)	8.0 (4.1)	8.6 (3.9)	9.1 (4.1)			80 (24.4)	7.4 (3.4)	7.7 (3.5)			
90 (27.4)	7.9 (3.6)	9.0 (4.1)	9.9 (4.5)	10.3 (4.7)	10.5 (4.8)	90 (27.4)	7.3 (3.7)	8.1 (3.7)	8.6 (3.9)	8.9 (4.0)	8.9 (4.0)	90 (27.4)	6.8 (3.1)	7.2 (3.3)	7.5 (3.4)		
100 (30.5)	7.3 (3.3)	8.4 (3.8)	9.3 (4.2)	9.9 (4.5)	10.1 (4.6)	100 (30.5)	6.8 (3.4)	7.5 (3.4)	8.1 (3.7)	8.5 (3.9)	8.6 (3.9)	100 (30.5)	6.3 (2.9)	6.8 (3.1)	7.2 (3.3)	7.3 (3.3)	
110 (33.5)	6.7 (3.0)	7.8 (3.5)	8.8 (4.0)	9.4 (4.3)	9.7 (4.4)	110 (33.5)	6.3 (3.2)	7.1 (3.2)	7.7 (3.5)	8.1 (3.7)	8.3 (3.8)	110 (33.5)	5.9 (2.7)	6.4 (2.9)	6.8 (3.1)	7.0 (3.2)	7.1 (3.2)
120 (36.6)	6.2 (2.8)	7.3 (3.3)	8.3 (3.8)	9.0 (4.1)	9.3 (4.2)	120 (36.6)	5.8 (2.6)	6.6 (3.0)	7.3 (3.3)	7.8 (3.5)	8.0 (3.6)	120 (36.6)	5.5 (2.5)	6.0 (2.7)	6.5 (2.9)	6.8 (3.1)	6.9 (3.1)
130 (39.6)	5.7 (2.6)	6.8 (3.1)	7.9 (3.6)	8.6 (3.9)	9.0 (4.1)	130 (39.6)	5.4 (2.4)	6.2 (2.8)	7.0 (3.2)	7.4 (3.4)	7.7 (3.5)	130 (39.6)	5.2 (2.4)	5.7 (2.6)	6.2 (2.8)	6.5 (2.9)	6.6 (3.0)
140 (42.7)	5.3 (2.4)	6.4 (2.9)	7.5 (3.4)	8.2 (3.7)	8.6 (3.9)	140 (42.7)	5.1 (2.3)	5.9 (2.7)	6.6 (3.0)	7.1 (3.2)	7.4 (3.4)	140 (42.7)		5.4 (2.4)	5.9 (2.7)	6.2 (2.8)	6.4 (2.9)
150 (45.7)	5.0 (2.3)	6.0 (2.7)	7.1 (3.2)	7.9 (3.6)	8.3 (3.8)	150 (45.7)		5.6 (2.5)	6.3 (2.9)	6.8 (3.1)	7.1 (3.2)	150 (45.7)		5.2 (2.4)	5.7 (2.6)	6.0 (2.7)	6.2 (2.8)
160 (48.8)		5.7 (2.6)	6.7 (3.0)	7.5 (3.4)	8.0 (3.6)	160 (48.8)		5.3 (2.4)	6.0 (2.7)	6.6 (3.0)	6.9 (3.1)	160 (48.8)		5.0 (2.3)	5.5 (2.5)	5.8 (2.6)	6.0 (2.7)
170 (51.8)		5.3 (2.4)	6.4 (2.9)	7.2 (3.3)	7.7 (3.5)	170 (51.8)		5.0 (2.3)	5.8 (2.6)	6.3 (2.9)	6.7 (3.0)	170 (51.8)			5.3 (2.4)	5.6 (2.5)	5.8 (2.6)
180 (54.9)		5.1 (2.3)	6.1 (2.8)	6.9 (3.1)	7.4 (3.4)	180 (54.9)			5.5 (2.5)	6.1 (2.8)	6.4 (2.9)	180 (54.9)			5.1 (2.3)	5.4 (2.4)	5.6 (2.5)
190 (57.9)			5.8 (2.6)	6.6 (3.0)	7.2 (3.3)	190 (57.9)			5.3 (2.4)	5.8 (2.6)	6.2 (2.8)	190 (57.9)			4.9 (2.2)	5.3 (2.4)	5.5 (2.5)
200 (61.0)			5.5 (2.5)	6.3 (2.9)	6.9 (3.1)	200 (61.0)			5.1 (2.3)	5.6 (2.5)	6.0 (2.7)	200 (61.0)			4.8 (2.2)	5.1 (2.3)	5.3 (2.4)
210 (64.0)			5.3 (2.4)	6.1 (2.8)	6.7 (3.0)	210 (64.0)			4.9 (2.2)	5.4 (2.4)	5.8 (2.6)	210 (64.0)				5.0 (2.3)	5.2 (2.4)
220 (67.1)			5.1 (2.3)	5.8 (2.6)	6.4 (2.9)	220 (67.1)				5.3 (2.4)	5.7 (2.6)	220 (67.1)				4.9 (2.2)	5.1 (2.3)
230 (70.1)			4.9 (2.2)	5.6 (2.5)	6.2 (2.9)	230 (70.1)				5.1 (2.3)	5.5 (2.5)	230 (70.1)				4.8 (2.2)	4.9 (2.2)
240 (73.2)				5.4 (2.4)	6.0 (2.7)	240 (73.2)				5.0 (2.3)	5.4 (2.4)	240 (73.2)					4.8 (2.2)
250 (76.2)				5.2 (2.4)	5.8 (2.6)	250 (76.2)				4.8 (2.2)	5.2 (2.4)	250 (76.2)					4.7 (2.1)
260 (79.2)				5.0 (2.3)	5.5 (2.5)	260 (79.2)				4.7 (2.1)	5.1 (2.3)	260 (79.2)					4 (1.8)
270 (82.3)				4.9 (2.2)	5.3 (2.4)	270 (82.3)					4.6 (2.1)	270 (82.3)					3.1 (1.4)

This material is supplied for reference use only. Operator must refer to in-cab Crane Rating Manual and Operator’s Manual to determine allowable crane lifting capacities and assembly and operating procedures.

This Page Intentionally Blank

Link-Belt Construction Equipment Company Lexington, Kentucky www.linkbelt.com

®Link-Belt is a registered trademark. Copyright 2014. We are constantly improving our products and therefore reserve the right to change designs and specifications.