

Technical Data

Specifications & Capacities

TCC 750

Telescopic Crawler Crane
75 Ton (70 metric ton)

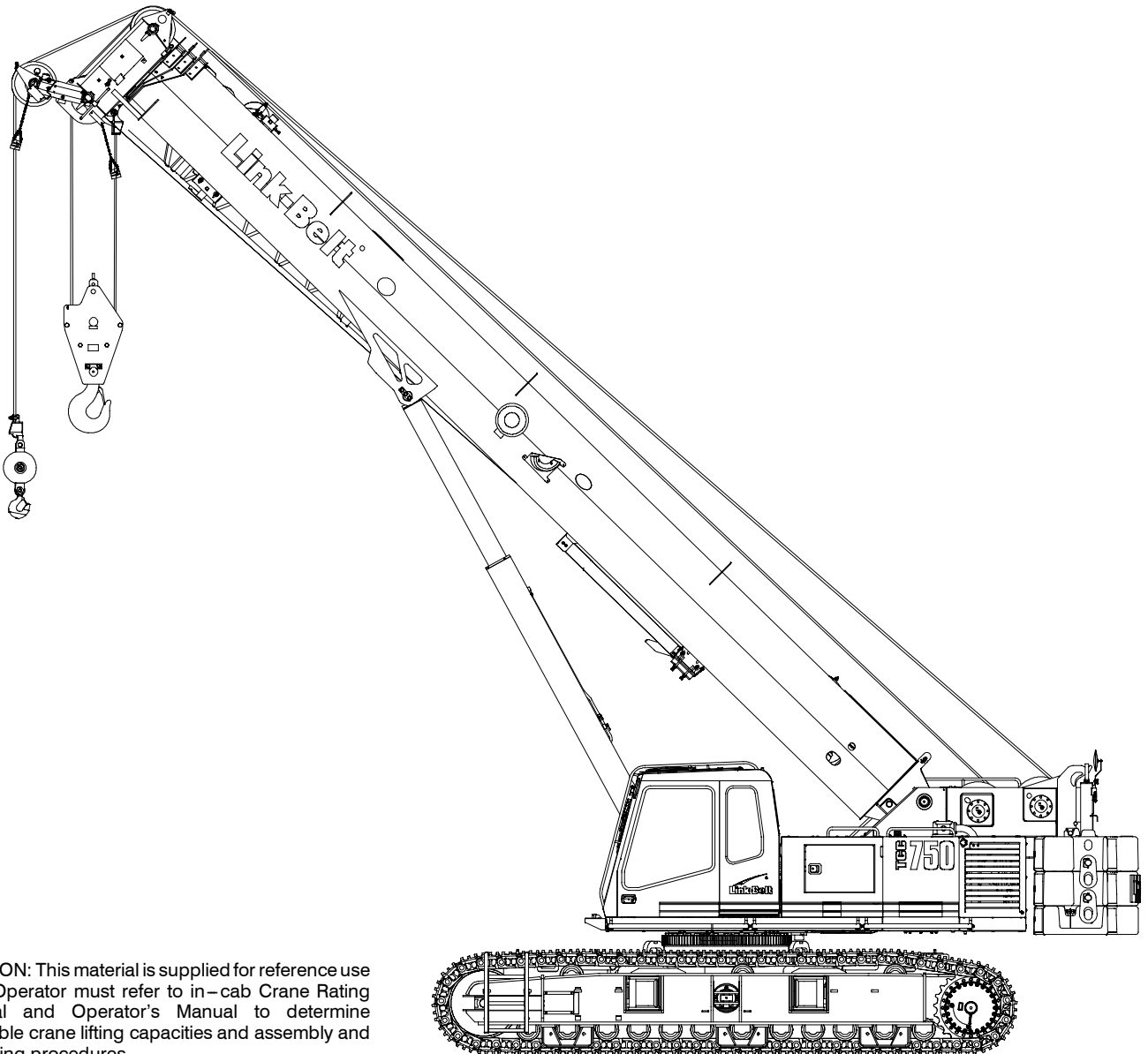

CAUTION: This material is supplied for reference use only. Operator must refer to in-cab Crane Rating Manual and Operator's Manual to determine allowable crane lifting capacities and assembly and operating procedures.

Table Of Contents

Upper Structure	1
Frame	1
Engine	1
Hydraulic System	1
Load Hoist Drums	1
Swing System	1
Counterweight	1
Operator's Cab	1
Rated Capacity Limiter System	2
Machinery House	2
Catwalks	2
Optional Vandal Guards	2
Lower Structure	2
Carbody	2
Side Frames	2
Travel and Steering	2
Optional Tool Boxes	2
Boom and Attachments	3
Design	3
Boom	3
Boom Wear Pads	3
Boom Head	3
Boom Elevation	3
Optional Auxiliary Lifting Sheave	3
Optional Hook Blocks And Balls	3
Optional Fly	3
Work Platform/Auger	3
Dimensions	4
Base Crane	4
Auxiliary Lifting Sheave	6
Counterweights	7
Hook Balls	8
Hook Blocks	8
Working Weights	9
Transport Drawing	9
Load Hoist Performance	9
Working Areas	10
Boom Extend Modes	11
Attachments	12
Main Boom Working Range Diagrams	13
Main Boom + Fly Working Range Diagrams	15
Main Boom Load Charts	16
Main Boom + Fly Load Charts	19

Upper Structure

Frame

All welded steel frame with precision machined surfaces for mating parts.

Turntable Bearing

- Inner race is bolted to upper frame
- Outer race with external swing gear is bolted to lower frame

Engine

Engine

Full pressure lubrication, oil filter, air cleaner, hour meter, throttle, and electric control shutdown.

Specification	CAT C6.6
Numbers of Cylinders	6
Cycle	4
Bore and Stroke: inch (mm)	4.13 x 5.00 (105 x 127)
Piston Displacement: in ³ (L)	402.7 (6.6)
Max. Brake Horsepower: hp (kW)	262 (195) @ 2,000 rpm
Peak Torque: ft lb (Nm)	775 (1 050) @ 1,400 rpm
Alternator: volts – amps	12 – 150
Crankcase Capacity: qt (L)	18.4 (17.4)
<ul style="list-style-type: none"> • Hydraulic driven fan and thermostatically controlled radiator 	

Fuel Tank

One 80 gal (303L) capacity fuel tank.

Hydraulic System

Hydraulic Pumps

The pump arrangement is designed to provide hydraulically powered functions allowing positive, precise control with independent or simultaneous operation of all crane functions.

- Two variable displacement pumps provide independent control for hoist drums, boom hoist, boom extend, and right & left travel.
- Three gear type pumps are used for the swing, retract cylinders & operator's controls, engine cooling fan, and hydraulic oil cooling fan.

Hydraulic Reservoir

165 gal (625L) capacity equipped with sight level gauge. Diffusers built in for deaeration.

Filtration

One 10 micron, full flow return line filter. Accessible for easy filter replacement.

Counterbalance Valves

All hoist motors are equipped with counterbalance valves to provide positive load lowering and prevent accidental load drop if the hydraulic pressure is suddenly lost.

Load Hoist Drums

Main and Optional Auxiliary Winches

- Axial piston, full and half displacement (2-speed) motor driven through planetary reduction unit for positive control under all load conditions.
- Grooved lagging
- Power up/down mode of operation
- Hoist drum cable follower – optional
- Drum rotation indicator
- Drum diameter: 16 in (40.6cm)
- Rope length:
 - Main: 630 ft (192.0m)
 - Auxiliary: 500 ft (152.4m) or 630 ft (192.0m)
- Maximum rope storage: 834 ft (254.2m)
- Terminator style socket and wedge

Third wrap indicator – optional – Visually and audibly warns the operator when the wire rope is on the first/bottom layer and when the wire rope is down to the last three wraps

Swing System

Motor/Planetary – Bi-directional hydraulic swing motor mounted to a planetary reducer for 360° continuous smooth swing at 2.0 rpm

Swing Park Brake – 360°, electric over hydraulic, (spring applied/hydraulic released) multi-disc brake mounted on the speed reducer. Operated by a switch in the operator's cab.

Swing Brake – 360°, foot operated, hydraulic applied disc brake mounted to the speed reducer

House Lock – Two-position house lock (boom over front or rear) operated from the operator's cab

Counterweight

Consists of a five piece design.

- One "A" counterweight, 12,000 lb (5 443kg)
- One "B" counterweight, 11,500 lb (5 216kg)
- One "C" counterweight, 11,500 lb (5 216kg)
- Two "A" carbody counterweights, 5,000 lb (2 268kg) each

Operator's Cab

Fully enclosed modular steel compartment is independently mounted and padded to protect against vibration and noise.

- All tinted/tempered safety glass
- Sliding entry door and front and rear window
- Swing up roof window with windshield wiper
- Door and window locks
- Hot water heater
- Air conditioner
- Sun visor
- Cloth seat
- Circulating fan
- Windshield wipers and washer
- Dry chemical fire extinguisher
- Engine instrumentation panel (tachometer, voltmeter, engine oil pressure, engine water temperature, fuel level, hydraulic oil temperature, hour meter, and service monitor system)
- Mechanical drum rotation indicators for main (rear) and auxiliary (front) hoist drums
- Six way adjustable seat
- Foot throttle
- Joystick controls
- Optional fully adjustable single axis controls
- Bubble type level
- Ergonomic gauge layout
- Controls shut off lever
- AM/FM Radio
- Travel levers & pedals

Rated Capacity Limiter System

Microguard graphic audio–visual warning system with anti–two block and function limiter. Operating data available includes:

- Crane configuration
- Boom length
- Boom head height
- Allowed load and % of allowed load
- Data logging

- Boom angle
- Radius of load
- Actual load
- Operator settable alarms (include):
 - Maximum and minimum boom angles
 - Maximum tip height
 - Maximum boom length
 - Swing left/right positions
 - Operator defined area (imaginary plane)

Machinery House

Hinged doors (four on right side, one on left side) for machinery access.

Catwalks

Standard on right and left sides. Catwalks fold up and pin for reduced travel width.

Optional Vandal Guards

Under design

Lower Structure

Carbody

Lower Frame

All welded box construction frame with precision machined surfaces for turntable bearing and rotating joint.

Side Frames

Side Frames

All welded, precision machined, steel frames can be hydraulically extended and retracted with a hydraulic cylinder mounted in the lower frame.

- 14 ft (4.27m) extended gauge
- 11 ft 11 in (3.63m) intermediate gauge
- 8 ft 5 in (2.57m) retracted gauge
- 20 ft 8.25 in (6.31m) overall length
- 36 in (0.91m) wide track shoes
- Sealed (oil filled) idler and drive planetaries
- Compact travel drives
- Hydraulic self adjusting tracks

Track Rollers

- Twelve sealed (oil filled) track rollers per side frame
- Heat treated, mounted on anti–friction bearings

Tracks

Heat treated, self–cleaning grouser shoes and heat treated track pins with dirt seals. 61 track shoes per side.

- Optional flat or “street” pad

Take Up Idlers

Cast steel, heat treated, self–cleaning, mounted on sealed tapered roller bearings

Travel and Steering

Each side frame contains a pilot controlled, bi–directional, axial piston motor and a planetary gear reduction unit to provide positive control under all load conditions.

- 2–speed travel
- Individual control provides smooth, precise maneuverability including full counter–rotation.
- Spring applied, hydraulically released multiple wet–disc type brake controlled automatically
- Maximum travel speed is 1.3 mph (1.9km/h).
- Designed to 40% gradeability

Optional Tool Boxes

Two heavy duty steel design tool boxes that bolt onto the carbody counterweights.

Boom and Attachments

Design

Four section, formed construction of extra high tensile steel consisting of one base section and three telescoping sections. Two plate design of each section has multiple longitudinal bends for superior strength. The first telescoping section extends independently by means of one double-acting, single stage hydraulic cylinder with integrated holding valves. The second and third telescoping sections extend proportionally by means of one double-acting, single stage cylinder with integrated holding valves and cables.

Boom

- 38.6–115.6 ft (11.8–35.2m) four section boom
- Two boom extend modes (A-max and Standard), controlled from the operator's cab, provide superior capacities by varying the extension of the telescoping sections:
 - A-max Mode extends to 64.2 ft (19.6m)
 - Standard mode extends to 115.6 ft (35.2m)
- Mechanical boom angle indicator
- Maximum tip height for each extend mode is:
 - A-max Mode is 72 ft (21.9m)
 - Standard Mode is 122 ft (37.2m)

Boom Wear Pads

- Wear pads with Teflon inserts that self-lubricate the boom sections
- Top and bottom wear pads are universal for all boom sections

Boom Head

- Five 16.5 in (41.9cm) root diameter nylon sheaves to handle up to ten parts of line
- Easily removable wire rope guards
- Rope dead end lugs on each side of the boom head
- Boom head is designed for quick-reeve of the hook block

Boom Elevation

- One double acting hydraulic cylinder with integral holding valve
- Boom elevation: -3° to 80°

Optional Auxiliary Lifting Sheave

- Single 16.5 in (41.9m) root diameter nylon sheave
- Easily removable wire rope guard
- Does not affect erection of the fly or use of the main head sheaves

Optional Hook Blocks And Balls

- 40 ton (36.3mt) 4 sheave quick-reeve hook block with safety latch
- 60 ton (54.4mt) 4 sheave quick-reeve hook block with safety latch
- 75 ton (68.0mt) 5 sheave quick-reeve hook block with safety latch
- 8.5 ton (7.7mt) swivel and non-swivel hook balls with safety latch
- 10 ton (9.1mt) swivel and non-swivel hook balls with safety latch

Optional Fly

- 35 ft (10.7m) one piece lattice fly, stowable, offsettable to 2° , 15° , 30° , and 45° . Maximum tip height is 156 ft (47.55m).
- 35–58 ft (10.7–17.7m) two piece bi-fold lattice fly, stowable, offsettable to 2° , 15° , 30° , and 45° . Maximum tip height is 179 ft (54.56m).

Work Platform/Auger

- Under design

Dimensions

Base Crane

General Dimensions	English	Metric
Basic Boom	38.6-115.6 ft	11.7-35.2m
Minimum Load Radius	10 ft	3.05m
Maximum Boom Angle	80°	80°
Track Shoe Width	36 in	0.91m

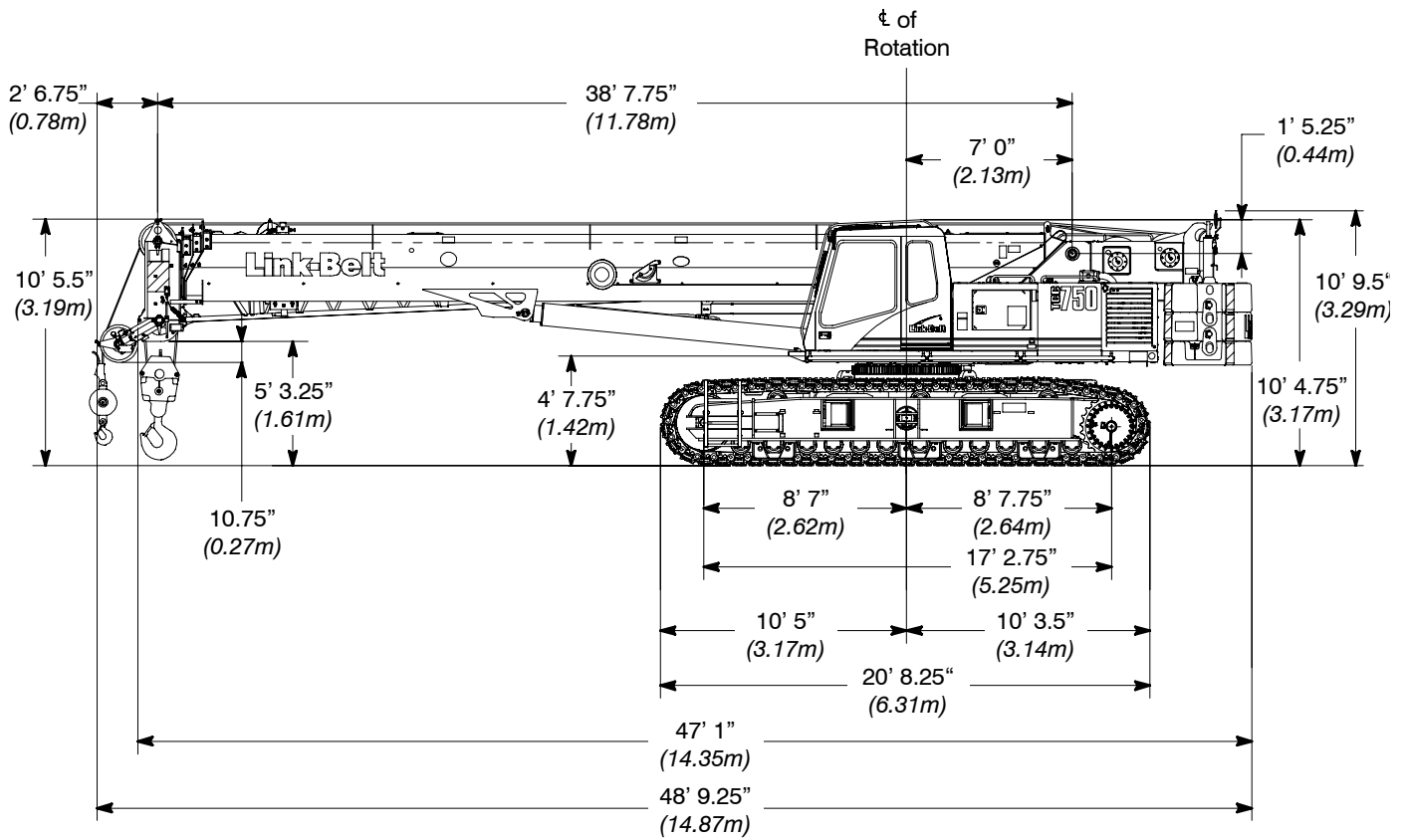

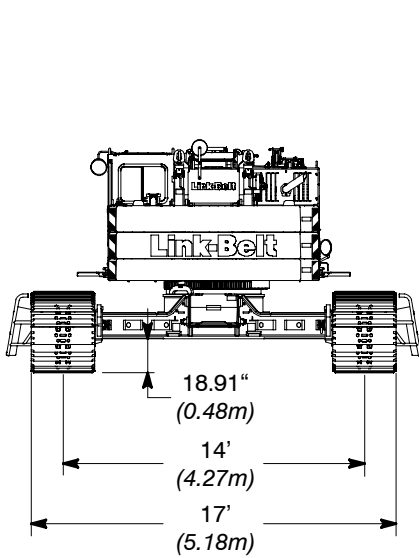
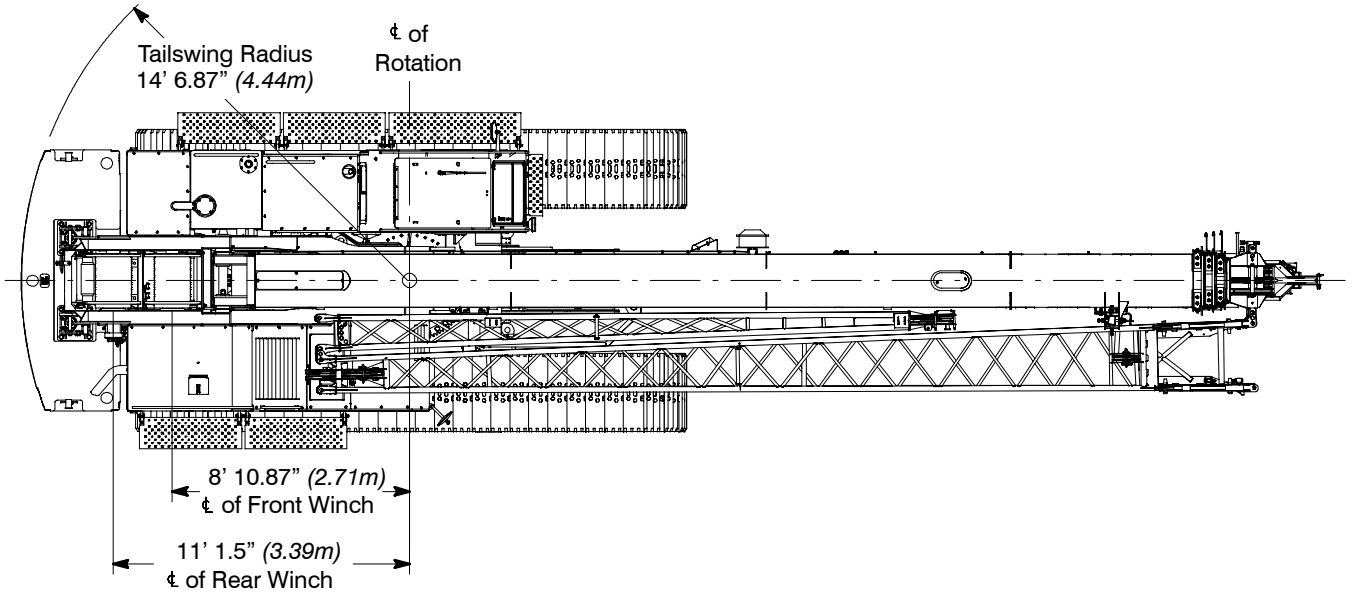

Extended Gauge

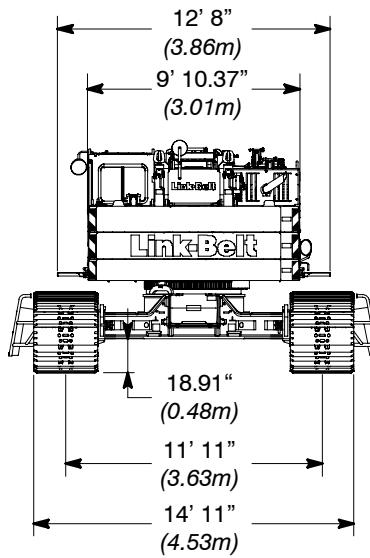

Intermediate Gauge

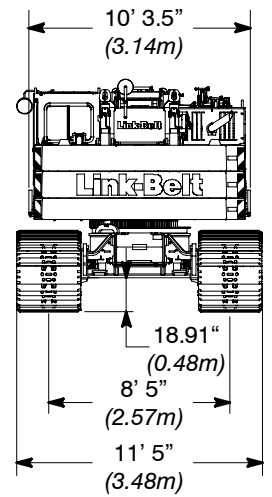

Retracted Gauge

Auxiliary Lifting Sheave

Auxiliary Lifting Sheave ①

Length	34.88 in	(0.89m)
Width	16.31 in	(0.41m)
Height	19 in	(0.48m)
Weight	84 lb	(38kg)

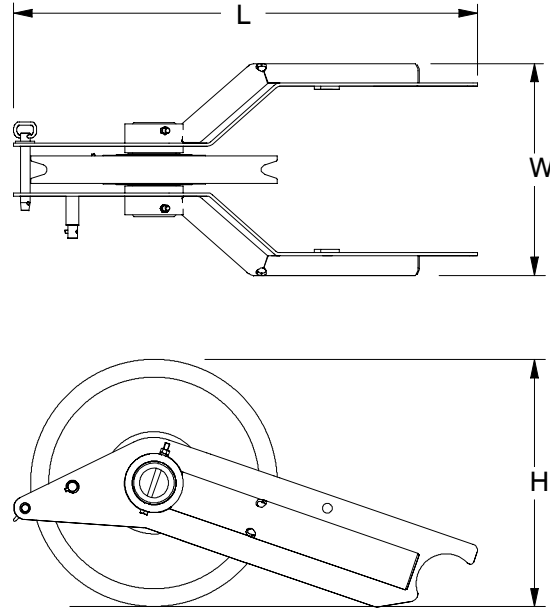

Fly

35 ft (10.7m) One Piece Lattice Fly (Base Fly) ①

Length	35 ft	(10.67m)
Width	29 in	(0.74m)
Height	40 in	(1.02m)
Weight	1,580 lb	(717kg)

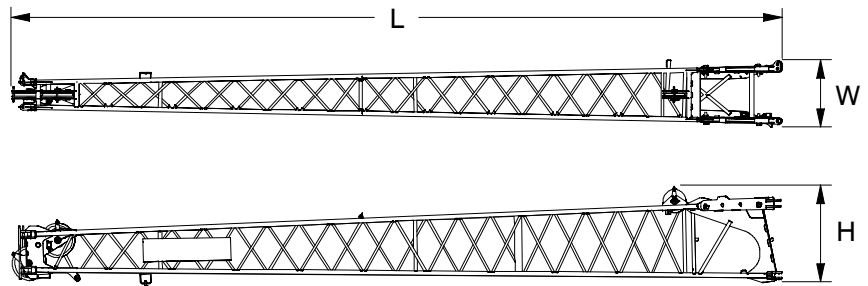

23 ft (7.01m) Lattice Fly Tip (Addition To Base Fly For 35-58 ft (10.7-17.7m) Bi-fold Fly) ①

Length	23 ft	(7.01m)
Width	14 in	(0.36m)
Height	22 in	(0.56m)
Weight	670 lb	(304kg)

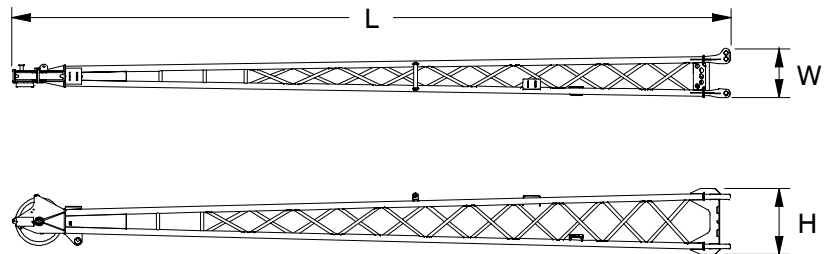

Number inside black circle “①” = # of components

* – Optional equipment

Counterweights

“A” Counterweight ❶

Length	44.50 in	(1.13m)
Width	9 ft 10 in	(3.00m)
Height	6 ft 0.5 in	(1.84m)
Weight	12,000 lb	(5 443kg)

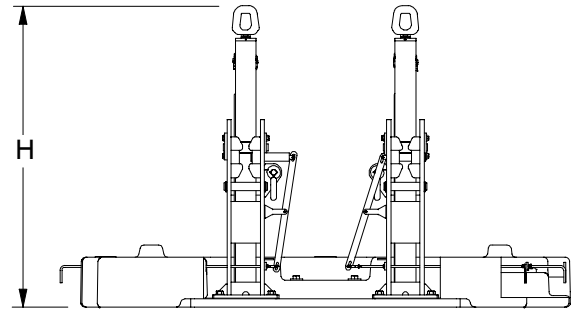
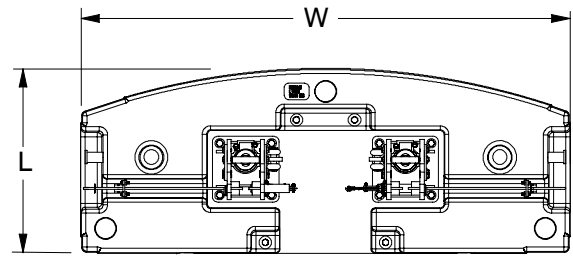

“B” & “C” Counterweights ❷

Length	44.50 in	(1.13m)
Width	9 ft 10 in	(3.00m)
Height	17.50 in	(0.44m)
Weight	11,500 lb	(5 216kg)

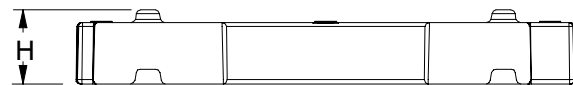
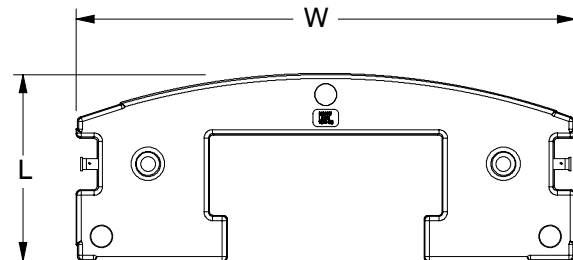

“A” Carbody Counterweights ❷

Length	53.12 in	(1.35m)
Width	32 in	(0.81m)
Height	19 in	(0.48m)
Weight	5,000 lb	(2 268kg)

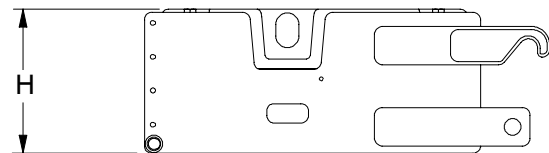
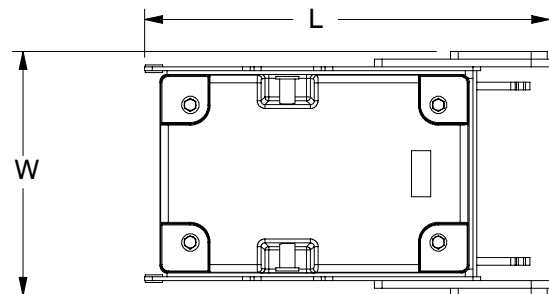

Number inside black circle “❶” = # of components
 * – Optional equipment

Hook Balls

8.5 Ton (7.7mt) Swivel Hook Ball* ①

Width	14.50 in	(0.37m)
Height	33.75 in	(0.86m)
Weight	360 lb	(163kg)

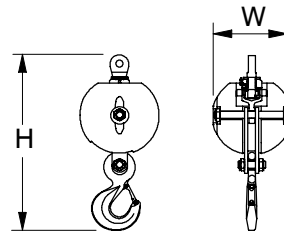

8.5 Ton (7.7mt) Non-Swivel Hook Ball* ①

Width	16.50 in	(0.42m)
Height	35 in	(0.89m)
Weight	360 lb	(163kg)

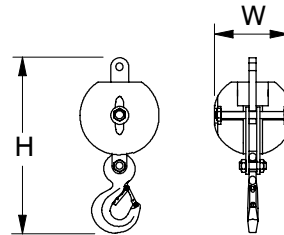

Hook Blocks

40 Ton (36.3mt)

4-Sheave Hook Block* ①

Width1	19.50 in	(0.50m)
Width2	18 in	(0.46m)
Height	48 in	(1.22m)
Weight	900 lb	(408kg)

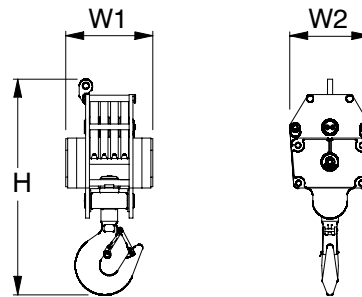

60 Ton (54.4mt)

4-Sheave Hook Block* ①

Width1	20.25 in	(0.51m)
Width2	20 in	(0.51m)
Height	54 in	(1.37m)
Weight	1,110 lb	(503kg)

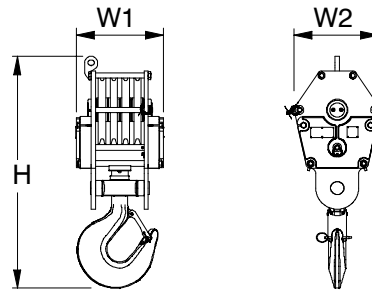

75 Ton (68.0mt)

5-Sheave Hook Block* ①

Width1	21.25 in	(0.54m)
Width2	20 in	(0.51m)
Height	63.25 in	(1.61m)
Weight	1,410 lb	(640kg)

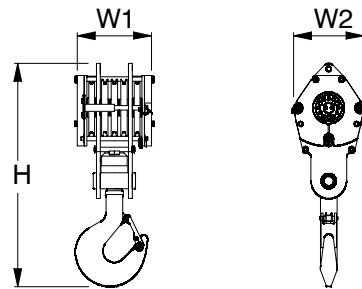

Number inside black circle “①” = # of components

* - Optional equipment

Working Weights

Option	Description	Gross Weight lb (kg)	Ground Bearing Pressure (on soft ground) psi (kg/cm ²)
1	Base crane, "ABC" counterweight, 2 piece carbody counterweight, 630 ft (192.0m) type "ZB" main wire rope, 500 ft (152.4m) type "ZB" auxiliary wire rope, 1 – piece fly, 60 ton (54.43mt) 4 sheave hook block, 8.5 ton (7.71mt) hook ball, and a 200 lb (90.7kg) operator.	145,470 (65 985kg)	9.71 (0.68)

Notes: Ground bearing pressure is based on the total weight distributed evenly over the track contact area.

Transport Drawing

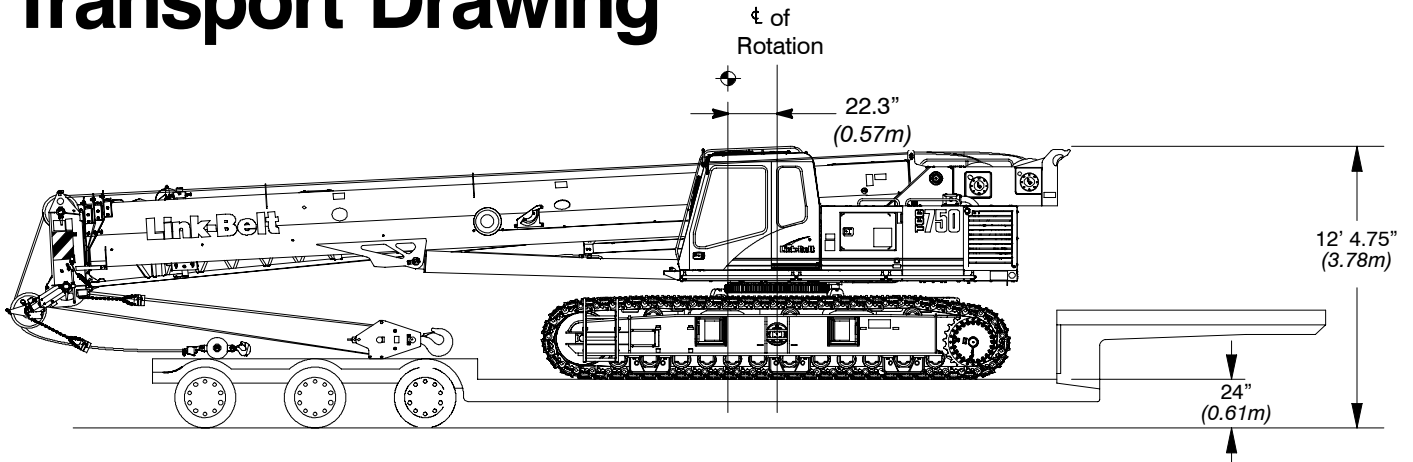

Transport Weight – 99,960 lb (45 342kg)

Base crane, 630 ft (192.0m) type "ZB" main wire rope, 500 ft (152.4m) type "ZB" auxiliary wire rope, 1 – piece fly, 60 ton (54.43mt) 4 sheave hook block, and 8.5 ton (7.71mt) hook ball.

Load Hoist Performance

Main (Rear) and Auxiliary (Front) Winches – 3/4 in (19mm) Rope										
Layer	Maximum Line Pull		Normal Line Speed		High Line Speed		Layer		Total	
	lb	kg	ft/min	m/min	ft/min	m/min	ft	m	ft	m
1	16,880	7 656.6	183	55.8	364	110.9	114	34.7	114	34.7
2	15,519	7 039.3	200	61.0	396	120.7	124	37.8	238	72.5
3	14,362	6 514.5	216	65.8	428	130.5	134	40.8	372	113.4
4	13,365	6 062.3	232	70.7	460	140.2	144	43.9	516	157.3
5	12,497	5 668.5	248	75.6	492	150.0	154	46.9	670	204.2
6	---	---	---	---	---	---	164	50.0	834	254.2

Wire Rope Application		Diameter		Type	Maximum Permissible Load	
		in	mm		lb	kg
Main (Rear) Winch	Standard	3/4	19	34x7 rotation resistant – right regular lay or right lang lay (Type ZB)	15,600	7 076.2
	Optional	3/4	19	18x19 rotation resistant – right regular lay or right lang lay (Type RB)	12,920	5 860.5
Auxiliary (Front) Winch	Standard	3/4	19	34x7 rotation resistant – right regular lay (Type ZB)	15,600	7 076.2
	Optional	3/4	19	18x19 rotation resistant – right regular lay (Type RB)	12,920	5 860.5

Working Areas

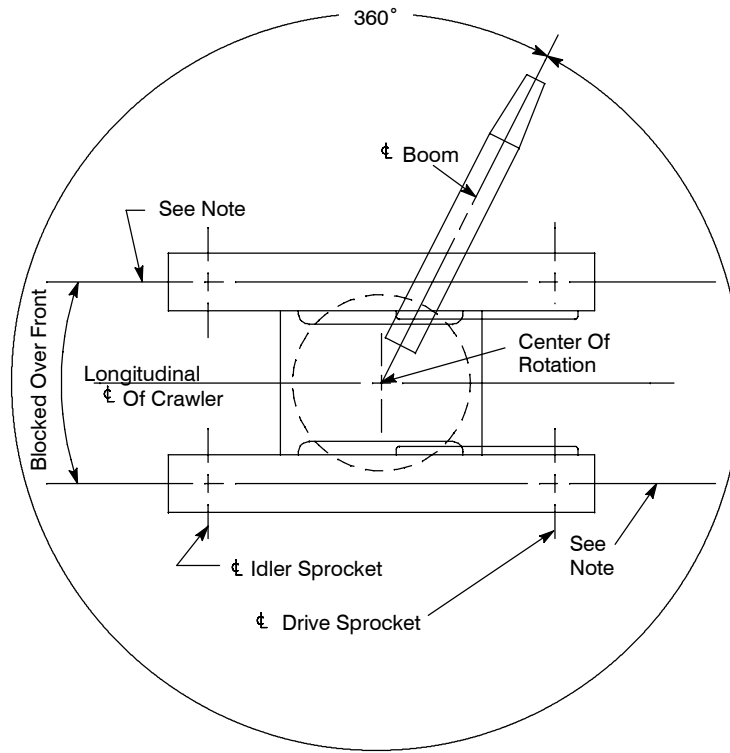

Note: These Lines Determine The Limiting Position Of Any Load For Operation Within Working Areas Indicated.

Boom Extend Modes

A-max Mode

Only inner mid section telescopes.

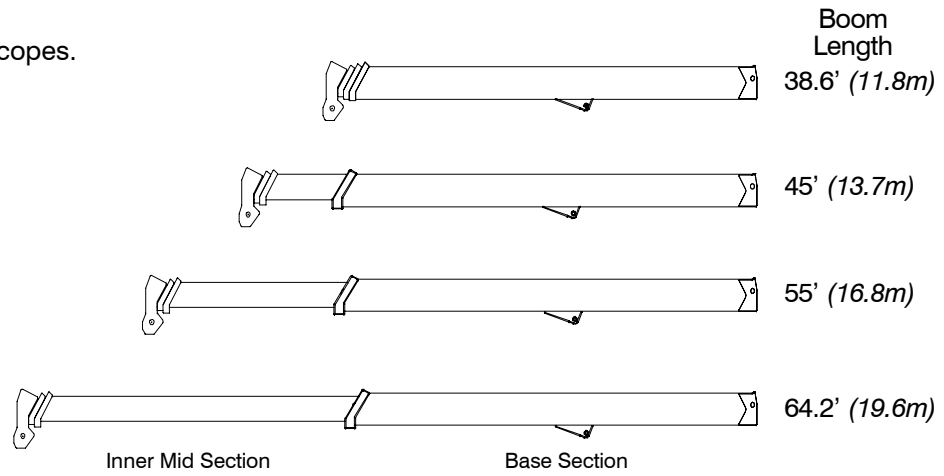

Standard Mode

Inner mid, outer mid, and tip sections telescope simultaneously.

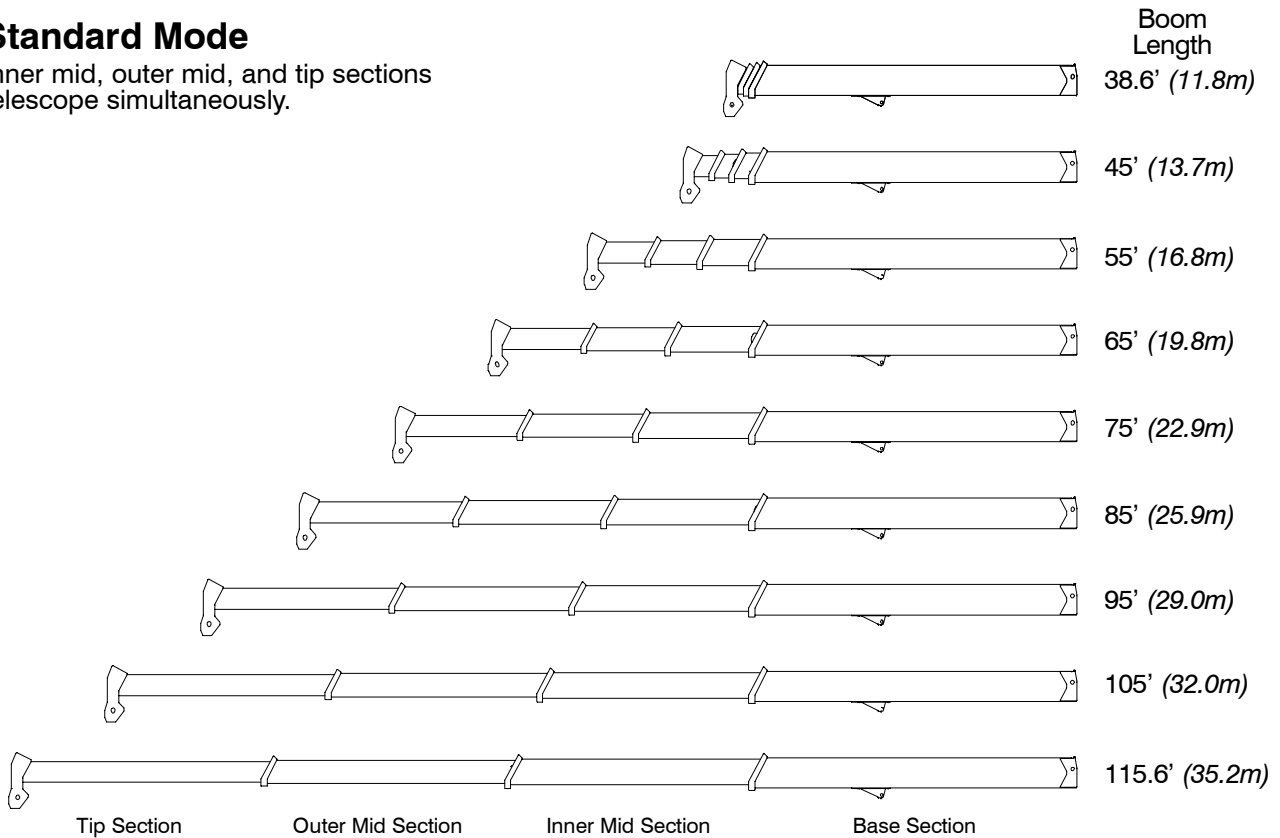

Attachments

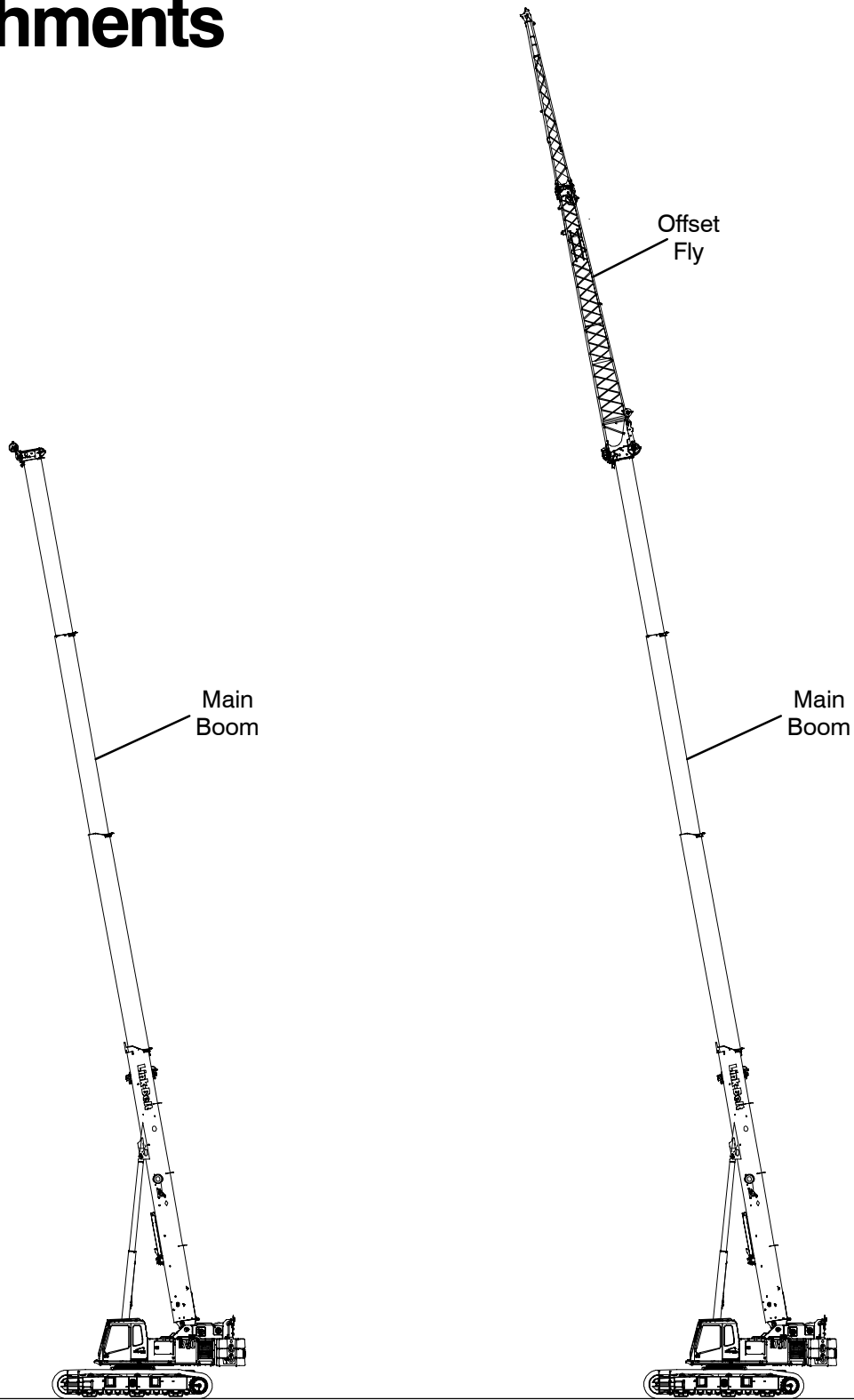

**38.6 – 115.6 ft (11.8 – 35.2m)
Main Boom**

**38.6 – 115.6 ft (11.8 – 35.2m) Main Boom
With 35 – 58 ft (10.7 – 17.7m) Offset Fly**

Main Boom Working Range Diagrams

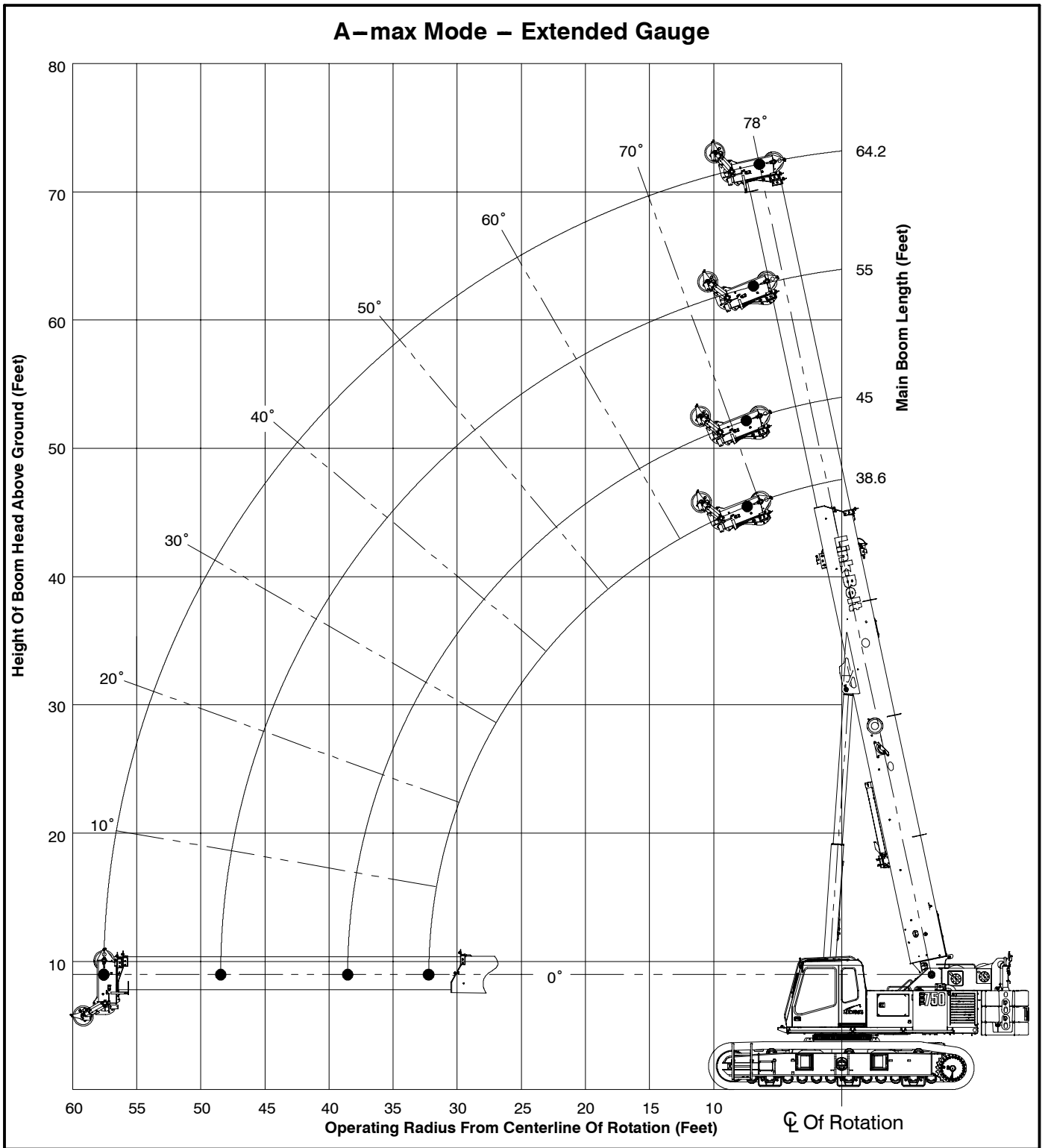

Standard Mode – Extended Gauge

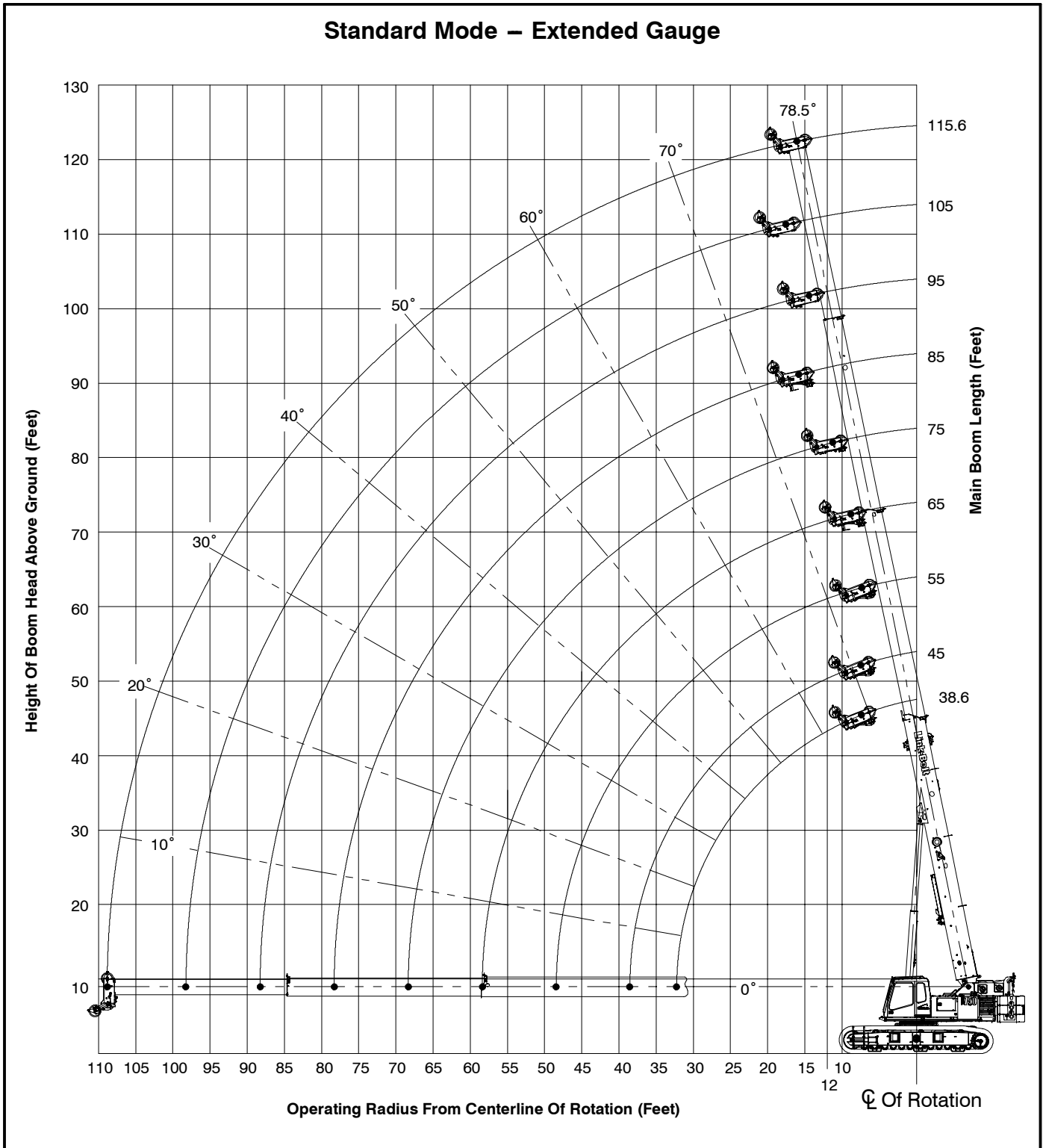

Main Boom + Fly Working Range Diagrams

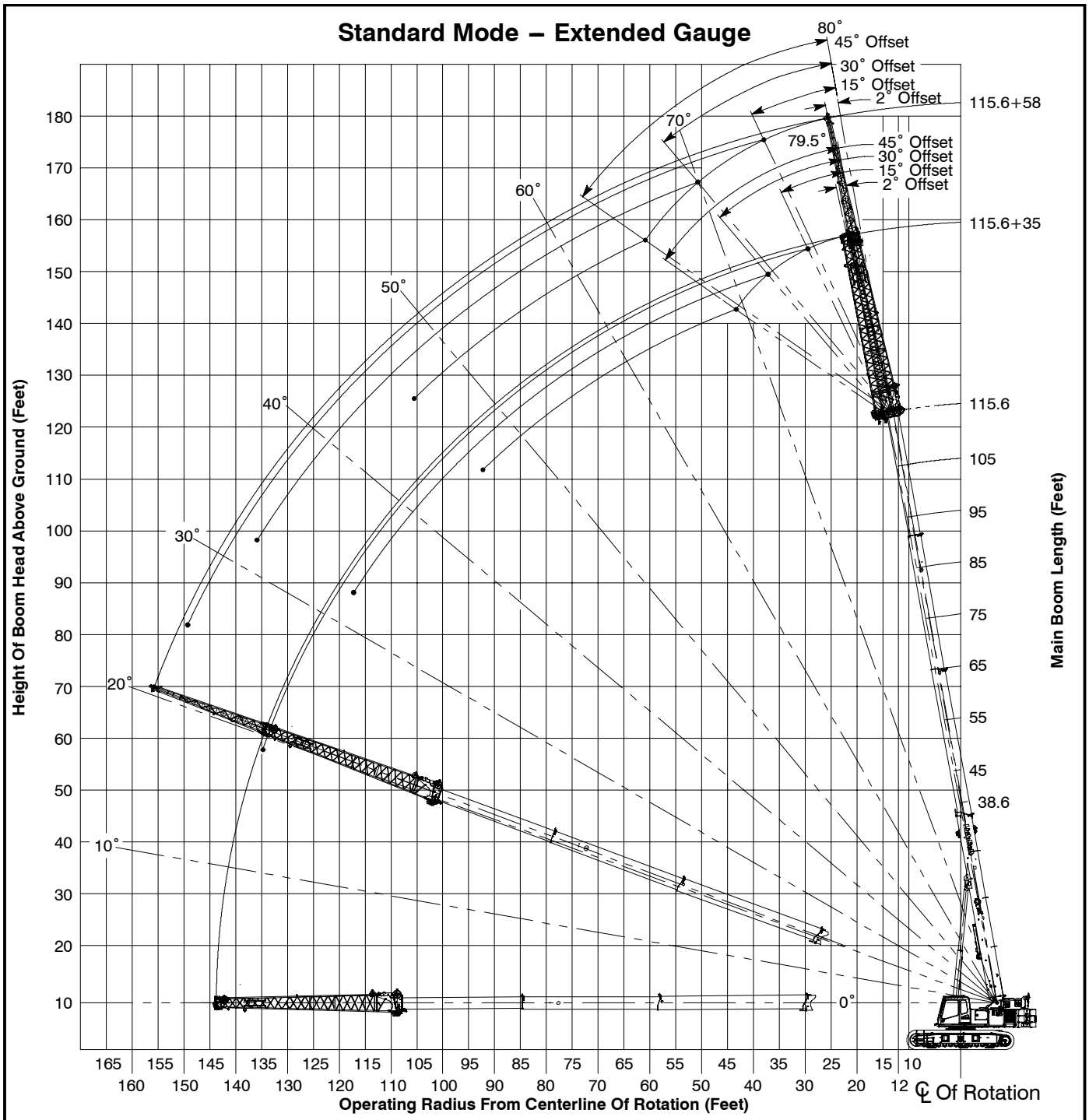

Main Boom Load Charts

Main Boom Lift Capacity Chart – 360° Rotation – Side Frames Extended Position
ABC+A [45,000 lb (20 412kg)] Counterweight
 [All capacities are listed in kips (mt)]

Load Radius ft (m)	Boom Length ft (m)									Load Radius ft (m)
	38.6 (11.8)	45 (13.7)	55 (16.8)	64.2 (19.8)	75 (22.9)	85 (25.9)	95 (29.0)	105 (32.0)	115.6 (35.2)	
10 (3.1)	150.3 (68.2)	106.2 (48.2)	104.1 (47.2)	74.8 (33.9)						10 (3.1)
12 (3.7)	136.6 (62.0)	106.2 (48.2)	104.1 (47.2)	74.8 (33.9)						12 (3.7)
15 (4.6)	112.9 (51.2)	106.2 (48.2)	104.1 (47.2)	74.8 (33.9)	52.0 (23.6)					15 (4.6)
20 (6.1)	78.9 (35.8)	78.2 (35.5)	77.4 (35.1)	74.8 (33.9)	52.0 (23.6)	52.0 (23.6)	52.0 (23.6)			20 (6.1)
25 (7.6)	53.9 (24.4)	53.5 (24.3)	52.9 (24.0)	52.4 (23.8)	52.0 (23.6)	52.0 (23.6)	52.0 (23.6)	51.5 (23.4)	40.0 (18.1)	25 (7.6)
30 (9.1)	39.9 (18.1)	40.6 (18.4)	41.2 (18.7)	41.5 (18.8)	41.7 (18.9)	41.8 (18.9)	41.9 (19.0)	42.0 (19.1)	40.0 (18.1)	30 (9.1)
35 (10.7)		31.6 (14.3)	32.2 (14.6)	32.6 (14.8)	32.7 (14.8)	32.9 (14.9)	32.9 (14.9)	33.0 (15.0)	33.1 (15.0)	35 (10.7)
40 (12.2)			26.0 (11.8)	26.4 (12.0)	26.6 (12.1)	26.7 (12.1)	26.8 (12.2)	26.9 (12.2)	27.0 (12.3)	40 (12.2)
45 (13.7)			21.4 (9.7)	21.8 (9.9)	22.1 (10.0)	22.2 (10.1)	22.3 (10.1)	22.3 (10.1)	22.4 (10.2)	45 (13.7)
50 (15.2)				18.3 (8.3)	18.5 (8.4)	18.7 (8.5)	18.8 (8.5)	18.9 (8.6)	18.9 (8.6)	50 (15.2)
55 (16.8)				15.5 (7.0)	15.7 (7.1)	15.9 (7.2)	16.0 (7.3)	16.1 (7.3)	16.1 (7.3)	55 (16.8)
60 (18.3)					13.5 (6.1)	13.7 (6.2)	13.9 (6.3)	14.0 (6.4)	14.0 (6.4)	60 (18.3)
65 (19.8)					11.6 (5.3)	11.8 (5.4)	12.0 (5.4)	12.1 (5.5)	12.2 (5.5)	65 (19.8)
70 (21.3)						10.3 (4.7)	10.4 (4.7)	10.5 (4.8)	10.6 (4.8)	70 (21.3)
75 (22.9)						8.9 (4.0)	9.1 (4.1)	9.2 (4.2)	9.3 (4.2)	75 (22.9)
80 (24.4)							7.9 (3.6)	8.0 (3.6)	8.1 (3.7)	80 (24.4)
85 (25.9)							6.9 (3.1)	7.0 (3.2)	7.1 (3.2)	85 (25.9)
90 (27.4)								6.1 (2.8)	6.2 (2.8)	90 (27.4)
95 (29.0)								5.4 (2.5)	5.4 (2.5)	95 (29.0)
100 (30.5)									4.7 (2.1)	100 (30.5)
105 (32.0)									4.1 (1.9)	105 (32.0)

This material is supplied for reference use only. Operator must refer to in-cab Crane Rating Manual and Operator's Manual to determine allowable crane lifting capacities and assembly and operating procedures.

Main Boom Lift Capacity Chart – 360° Rotation – Side Frames Intermediate Position
ABC+A [45,000 lb (20 412kg)] Counterweight
[All capacities are listed in kips (mt)]

Load Radius ft (m)	Boom Length ft (m)									Load Radius ft (m)
	38.6 (11.8)	45 (13.7)	55 (16.8)	65 (19.8)	75 (22.9)	85 (25.9)	95 (29.0)	105 (32.0)	115.6 (35.2)	
10 (3.1)	150.0 (68.0)	106.2 (48.2)								10 (3.1)
12 (3.7)	136.6 (62.0)	106.2 (48.2)	104.1 (47.2)							12 (3.7)
15 (4.6)	109.4 (49.6)	106.2 (48.2)	104.1 (47.2)	74.8 (33.9)						15 (4.6)
20 (6.1)	66.3 (30.1)	65.7 (29.8)	65.0 (29.5)	64.5 (29.3)	52.0 (23.6)	52.0 (23.6)				20 (6.1)
25 (7.6)	46.1 (20.9)	46.7 (21.2)	47.2 (21.4)	47.5 (21.5)	47.7 (21.6)	47.8 (21.7)	47.9 (21.7)			25 (7.6)
30 (9.1)	34.3 (15.6)	34.9 (15.8)	35.6 (16.1)	35.9 (16.3)	36.1 (16.4)	36.2 (16.4)	36.3 (16.5)	36.3 (16.5)		30 (9.1)
35 (10.7)		27.3 (12.4)	37.9 (17.2)	28.3 (12.8)	28.5 (12.9)	28.6 (13.0)	28.7 (13.0)	28.8 (13.1)	28.9 (13.1)	35 (10.7)
40 (12.2)			22.5 (10.2)	22.9 (10.4)	23.1 (10.5)	23.3 (10.6)	23.4 (10.6)	23.4 (10.6)	23.5 (10.7)	40 (12.2)
45 (13.7)			18.4 (8.3)	18.8 (8.5)	19.1 (8.7)	19.3 (8.8)	19.4 (8.8)	19.4 (8.8)	19.5 (8.8)	45 (13.7)
50 (15.2)				15.7 (7.1)	16.0 (7.3)	16.2 (7.3)	16.3 (7.4)	16.4 (7.4)	16.4 (7.4)	50 (15.2)
55 (16.8)				13.3 (6.0)	13.6 (6.2)	13.8 (6.3)	13.9 (6.3)	14.0 (6.4)	14.1 (6.4)	55 (16.8)
60 (18.3)					11.6 (5.3)	11.8 (5.4)	11.9 (5.4)	12.0 (5.4)	12.1 (5.5)	60 (18.3)
65 (19.8)					9.9 (4.5)	10.1 (4.6)	10.2 (4.6)	10.3 (4.7)	10.4 (4.7)	65 (19.8)
70 (21.3)						8.7 (3.9)	8.8 (4.0)	8.9 (4.0)	9.0 (4.1)	70 (21.3)
75 (22.9)						7.5 (3.4)	7.6 (3.4)	7.7 (3.5)	7.8 (3.5)	75 (22.9)
80 (24.4)							6.6 (3.0)	6.7 (3.0)	6.8 (3.1)	80 (24.4)
85 (25.9)							5.7 (2.6)	5.8 (2.6)	5.9 (2.7)	85 (25.9)
90 (27.4)								5.0 (2.3)	5.1 (2.3)	90 (27.4)
95 (29.0)								4.3 (2.0)	4.4 (2.0)	95 (29.0)
100 (30.5)									3.7 (1.7)	100 (30.5)
105 (32.0)									3.2 (1.5)	105 (32.0)

This material is supplied for reference use only. Operator must refer to in-cab Crane Rating Manual and Operator's Manual to determine allowable crane lifting capacities and assembly and operating procedures.

Main Boom Lift Capacity Chart – 360° Rotation – Side Frames Retracted Position
AB+A [33,500 lb (15 195kg)] Counterweight
[All capacities are listed in kips (mt)]

Load Radius ft (m)	Boom Length ft (m)									Load Radius ft (m)
	38.6 (11.8)	45 (13.7)	55 (16.8)	65 (19.8)	75 (22.9)	85 (25.9)	95 (29.0)	105 (32.0)	115.6 (35.2)	
12 (3.7)	88.2 (40.0)									12 (3.7)
15 (4.6)	60.5 (27.4)	52.0 (23.6)								15 (4.6)
20 (6.1)	37.9 (17.2)	38.5 (17.5)	39.0 (17.7)							20 (6.1)
25 (7.6)	26.3 (11.9)	26.9 (12.2)	27.6 (12.5)	27.9 (12.7)						25 (7.6)
30 (9.1)	19.2 (8.7)	19.8 (9.0)	20.4 (9.3)	20.8 (9.4)	21.0 (9.5)	21.2 (9.6)				30 (9.1)
35 (10.7)		15.1 (6.8)	15.7 (7.1)	16.0 (7.3)	16.3 (7.4)	16.4 (7.4)	16.5 (7.5)			35 (10.7)
40 (12.2)			12.3 (5.6)	12.7 (5.8)	12.9 (5.9)	13.1 (5.9)	13.2 (6.0)	13.3 (6.0)		40 (12.2)
45 (13.7)			9.7 (4.4)	10.1 (4.6)	10.3 (4.7)	10.5 (4.8)	10.7 (4.9)	10.8 (4.9)	10.8 (4.9)	45 (13.7)
50 (15.2)				8.0 (3.6)	8.3 (3.8)	8.5 (3.9)	8.7 (3.9)	8.8 (4.0)	8.8 (4.0)	50 (15.2)
55 (16.8)				6.4 (2.9)	6.7 (3.0)	6.9 (3.1)	7.0 (3.2)	7.1 (3.2)	7.2 (3.3)	55 (16.8)
60 (18.3)					5.3 (2.4)	5.5 (2.5)	5.7 (2.6)	5.8 (2.6)	5.9 (2.7)	60 (18.3)
65 (19.8)					4.2 (1.9)	4.4 (2.0)	4.6 (2.1)	4.7 (2.1)	4.8 (2.2)	65 (19.8)
70 (21.3)						3.5 (1.6)	3.6 (1.6)	3.7 (1.7)	3.8 (1.7)	70 (21.3)
75 (22.9)						2.7 (1.2)	2.8 (1.3)	2.9 (1.3)	3.0 (1.4)	75 (22.9)
80 (24.4)							2.1 (1.0)	2.2 (1.0)	2.3 (1.0)	80 (24.4)
85 (25.9)							1.5 (0.7)	1.6 (0.7)	1.7 (0.8)	85 (25.9)
90 (27.4)								1.1 (0.5)	1.2 (0.5)	90 (27.4)

This material is supplied for reference use only. Operator must refer to in-cab Crane Rating Manual and Operator's Manual to determine allowable crane lifting capacities and assembly and operating procedures.

Main Boom + Fly Load Charts

115.6 ft Main Boom + Fly – 360° Rotation – Standard Mode – Side Frames Extended Position
ABC+A [45,000 lb (20 412kg)] Counterweight
 [All capacities are listed in kips (mt)]

Load Radius ft (m)	2° Offset Fly		Load Radius ft (m)	15° Offset Fly		Load Radius ft (m)	30° Offset Fly		Load Radius ft (m)	45° Offset Fly	
	Fly Length – ft (m)			Fly Length – ft (m)			Fly Length – ft (m)			Fly Length – ft (m)	
	35 (10.7)	58 (17.7)		35 (10.7)	58 (17.7)		35 (10.7)	58 (17.7)		35 (10.7)	58 (17.7)
30 (9.1)	20.5 (9.3)		30 (9.1)			30 (9.1)			30 (9.1)		
35 (10.7)	19.4 (8.8)	12.0 (5.4)	35 (10.7)			35 (10.7)			35 (10.7)		
40 (12.2)	18.4 (8.3)	11.5 (5.2)	40 (12.2)	13.9 (6.3)		40 (12.2)			40 (12.2)		
45 (13.7)	17.4 (7.9)	10.9 (4.9)	45 (13.7)	13.4 (6.0)		45 (13.7)	11.2 (5.0)		45 (13.7)		
50 (15.2)	16.5 (7.5)	10.4 (4.7)	50 (15.2)	12.9 (5.8)	8.4 (3.8)	50 (15.2)	10.9 (4.9)		50 (15.2)		
55 (16.8)	14.8 (6.7)	9.9 (4.4)	55 (16.8)	12.4 (5.6)	8.1 (3.6)	55 (16.8)	10.6 (4.8)		55 (16.8)	9.4 (4.2)	
60 (18.3)	14.2 (6.4)	9.5 (4.3)	60 (18.3)	12.0 (5.4)	7.7 (3.4)	60 (18.3)	10.3 (4.6)		60 (18.3)	9.3 (4.2)	
65 (19.8)	13.1 (5.9)	9.0 (4.0)	65 (19.8)	11.6 (5.2)	7.4 (3.3)	65 (19.8)	10.1 (4.5)	6.2 (2.8)	65 (19.8)	9.1 (4.1)	
70 (21.3)	11.5 (5.2)	8.6 (3.9)	70 (21.3)	11.2 (5.0)	7.2 (3.2)	70 (21.3)	9.8 (4.4)	6.0 (2.7)	70 (21.3)	9.0 (4.0)	
75 (22.9)	10.2 (4.6)	8.2 (3.7)	75 (22.9)	10.8 (4.8)	6.9 (3.1)	75 (22.9)	9.6 (4.3)	5.8 (2.6)	75 (22.9)	8.9 (4.0)	5.2 (2.3)
80 (24.4)	9.0 (4.0)	7.9 (3.5)	80 (24.4)	9.6 (4.3)	6.7 (3.0)	80 (24.4)	9.4 (4.2)	5.7 (2.5)	80 (24.4)	8.8 (3.9)	5.1 (2.3)
85 (25.9)	8.0 (3.6)	7.6 (3.4)	85 (25.9)	8.5 (3.8)	6.4 (2.9)	85 (25.9)	9.0 (4.0)	5.6 (2.5)	85 (25.9)	8.8 (3.9)	5.0 (2.2)
90 (27.4)	7.1 (3.2)	7.2 (3.2)	90 (27.4)	7.6 (3.4)	6.2 (2.8)	90 (27.4)	8.0 (3.6)	5.4 (2.4)	90 (27.4)	8.3 (3.7)	4.9 (2.2)
95 (29.0)	6.3 (2.8)	6.9 (3.1)	95 (29.0)	6.7 (3.0)	6.0 (2.7)	95 (29.0)	7.1 (3.2)	5.3 (2.4)	95 (29.0)	7.4 (3.3)	4.9 (2.2)
100 (30.5)	5.6 (2.5)	6.2 (2.8)	100 (30.5)	6.0 (2.7)	5.9 (2.6)	100 (30.5)	6.3 (2.8)	5.2 (2.3)	100 (30.5)	6.5 (2.9)	4.8 (2.1)
105 (32.0)	5.0 (2.2)	5.5 (2.4)	105 (32.0)	5.3 (2.4)	5.7 (2.5)	105 (32.0)	5.6 (2.5)	5.1 (2.3)	105 (32.0)	5.8 (2.6)	4.8 (2.1)
110 (33.5)	4.5 (2.0)	5.0 (2.2)	110 (33.5)	4.7 (2.1)	5.5 (2.4)	110 (33.5)	5.0 (2.2)	5.0 (2.2)	110 (33.5)	5.1 (2.3)	4.7 (2.1)
115 (35.1)	3.9 (1.7)	4.4 (1.9)	115 (35.1)	4.2 (1.9)	4.9 (2.2)	115 (35.1)	4.4 (1.9)	4.9 (2.2)	115 (35.1)	4.5 (2.0)	4.7 (2.1)
120 (36.6)	3.5 (1.5)	4.0 (1.8)	120 (36.6)	3.7 (1.6)	4.4 (1.9)	120 (36.6)	3.9 (1.7)	4.8 (2.1)	120 (36.6)		4.7 (2.1)
125 (38.1)	3.1 (1.4)	3.5 (1.5)	125 (38.1)	3.2 (1.4)	3.9 (1.7)	125 (38.1)	3.4 (1.5)	4.3 (1.9)	125 (38.1)		4.5 (2.0)
130 (39.6)	2.7 (1.2)	3.1 (1.4)	130 (39.6)	2.8 (1.2)	3.5 (1.5)	130 (39.6)	2.9 (1.3)	3.8 (1.7)	130 (39.6)		4.0 (1.8)
135 (41.1)	2.3 (1.0)	2.8 (1.3)	135 (41.1)	2.4 (1.0)	3.1 (1.4)	135 (41.1)		3.4 (1.5)	135 (41.1)		3.5 (1.5)
140 (42.7)	2.0 (0.9)	2.4 (1.1)	140 (42.7)	2.1 (0.9)	2.7 (1.2)	140 (42.7)		2.9 (1.3)	140 (42.7)		3.0 (1.3)
145 (44.2)		2.1 (0.9)	145 (44.2)		2.4 (1.0)	145 (44.2)		2.6 (1.1)	145 (44.2)		
150 (45.7)		1.8 (0.8)	150 (45.7)		2.0 (0.9)	150 (45.7)		2.2 (0.9)	150 (45.7)		
155 (47.2)		1.6 (0.7)	155 (47.2)		1.7 (0.7)	155 (47.2)		1.8 (0.8)	155 (47.2)		
160 (48.8)		1.3 (0.5)	160 (48.8)		1.5 (0.6)	160 (48.8)			160 (48.8)		

This material is supplied for reference use only. Operator must refer to in-cab Crane Rating Manual and Operator's Manual to determine allowable crane lifting capacities and assembly and operating procedures.

Link-Belt Construction Equipment Company Lexington, Kentucky www.linkbelt.com

®Link-Belt is a registered trademark. Copyright 2009. We are constantly improving our products and therefore reserve the right to change designs and specifications.